



Sheet 11

Sheet 12

Sheet 15

Sheet 13

Sheet 16

Sheet 17

152/6/10

© 2025 RPS Group

Notes

- 1. This drawing has been prepared in accordance with the scope of RPS's appointment with its client and is subject to the terms and conditions of that appointment. RPS accepts no liability for any use of this document other than by its client and only for the purposes for which it was prepared and provided.
- 2. If received electronically it is the recipients responsibility to print to correct scale. Only written dimensions should be used.

Legend

- Order Limits
- Public Rights of Way
- Footpath

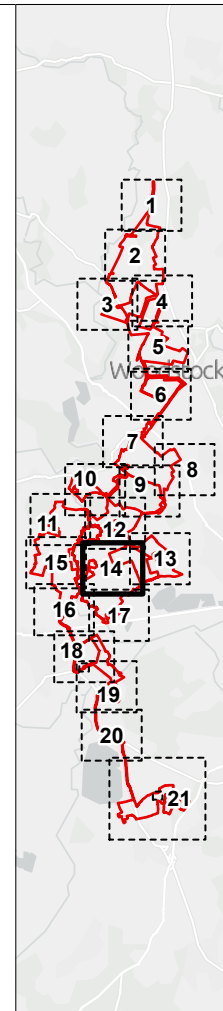

Rev	Description	By	CB	Date



PHOTOVOLT
DEVELOPMENT PARTNERS



RPS
A TETRA TECH COMPANY

Client **PVDP**

Project **Botley West Solar Farm**

Title **Appendix A: Location of outline
PRoW management measures**

Status	Drawn By	PM/Checked By
FINAL	AC	BJ
Project Number	Scale @ A3	Date Created
NP12426	1:5,000	SEP 2025
Figure Number		Rev
A14		03

rpsgroup.com
20 Western Avenue, Milton Park, Abingdon, Oxfordshire, OX14 4SH
T: +44(0)1235 821 888 E: rps@rpsgroup.com

P:\eur-mpfs-02.eur.rpsgroup.com\Projects\12426 Proposed DCO Scale Solar Development 860mw\Tech\Drawings\12426-0222-03.aprx

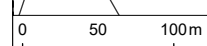

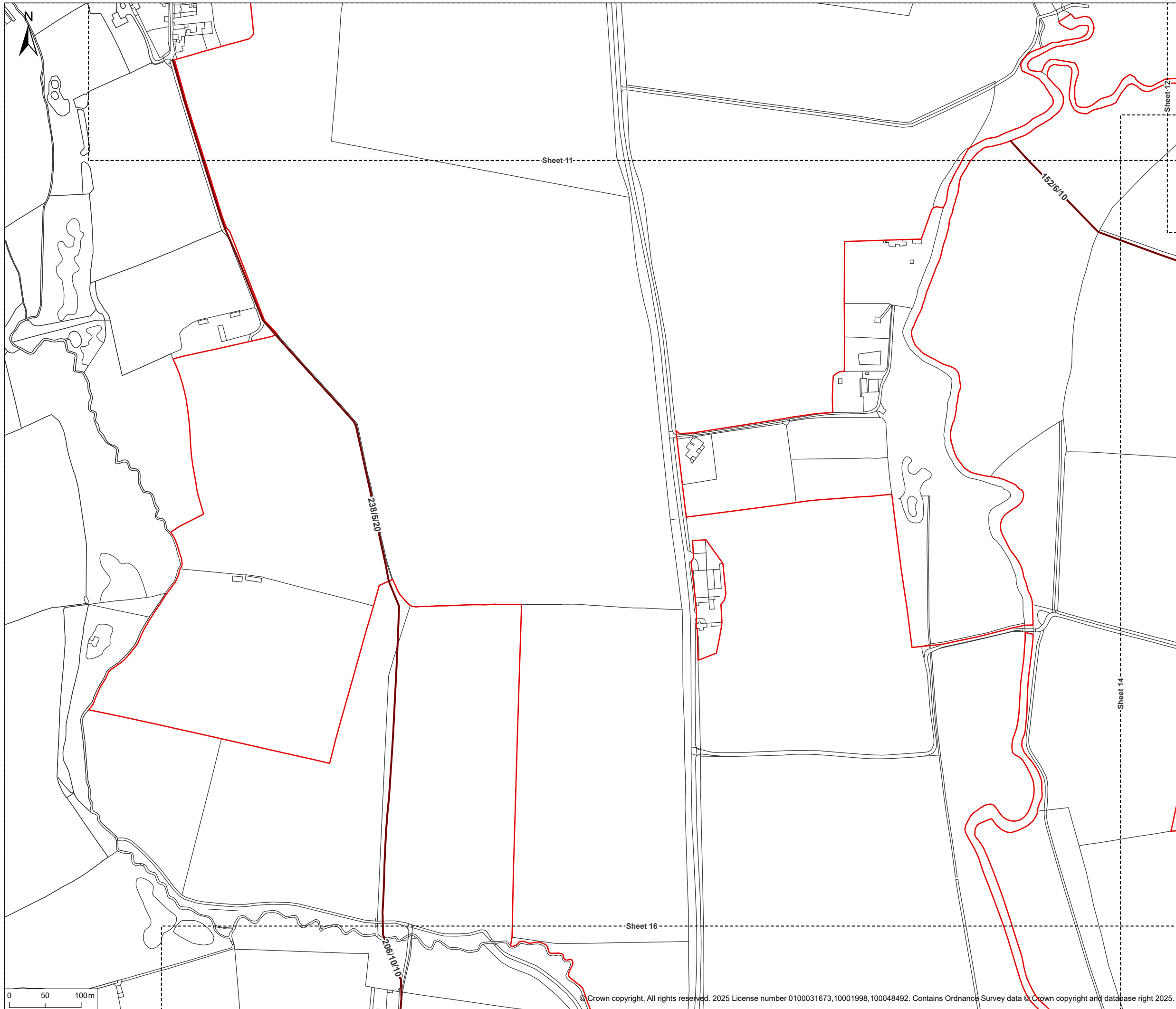

© 2025 RPS Group
 Notes
 1. This drawing has been prepared in accordance with the scope of RPS's appointment with its client and is subject to the terms and conditions of that appointment. RPS accepts no liability for any use of this document other than by its client and only for the purposes for which it was prepared and provided.
 2. If received electronically it is the recipients responsibility to print to correct scale. Only written dimensions should be used.

Legend

- Order Limits
- Public Rights of Way**
- Footpath

Rev	Description	By	CB	Date



PHOTOVOLT
DEVELOPMENT PARTNERS



RPS
A TETRA TECH COMPANY

Client **PVDP**

Project **Botley West Solar Farm**

Title **Appendix A: Location of outline PRow management measures**

Status **FINAL** Drawn By **AC** PM/Checked By **BJ**

Project Number **NP12426** Scale @ A3 **1:5,000** Date Created **SEP 2025**

Figure Number **A15** Rev **03**

rpsgroup.com
 20 Western Avenue, Milton Park, Abingdon, Oxfordshire, OX14 4SH
 T: +44(0)1235 821 888 E: rps@rpsgroup.com

P:\eur-mpfs-02.eur.rpsgroup.com\Projects\12426 Proposed DCO Scale Solar Development 860mw\Tech\Drawings\12426-0222-03.aprx

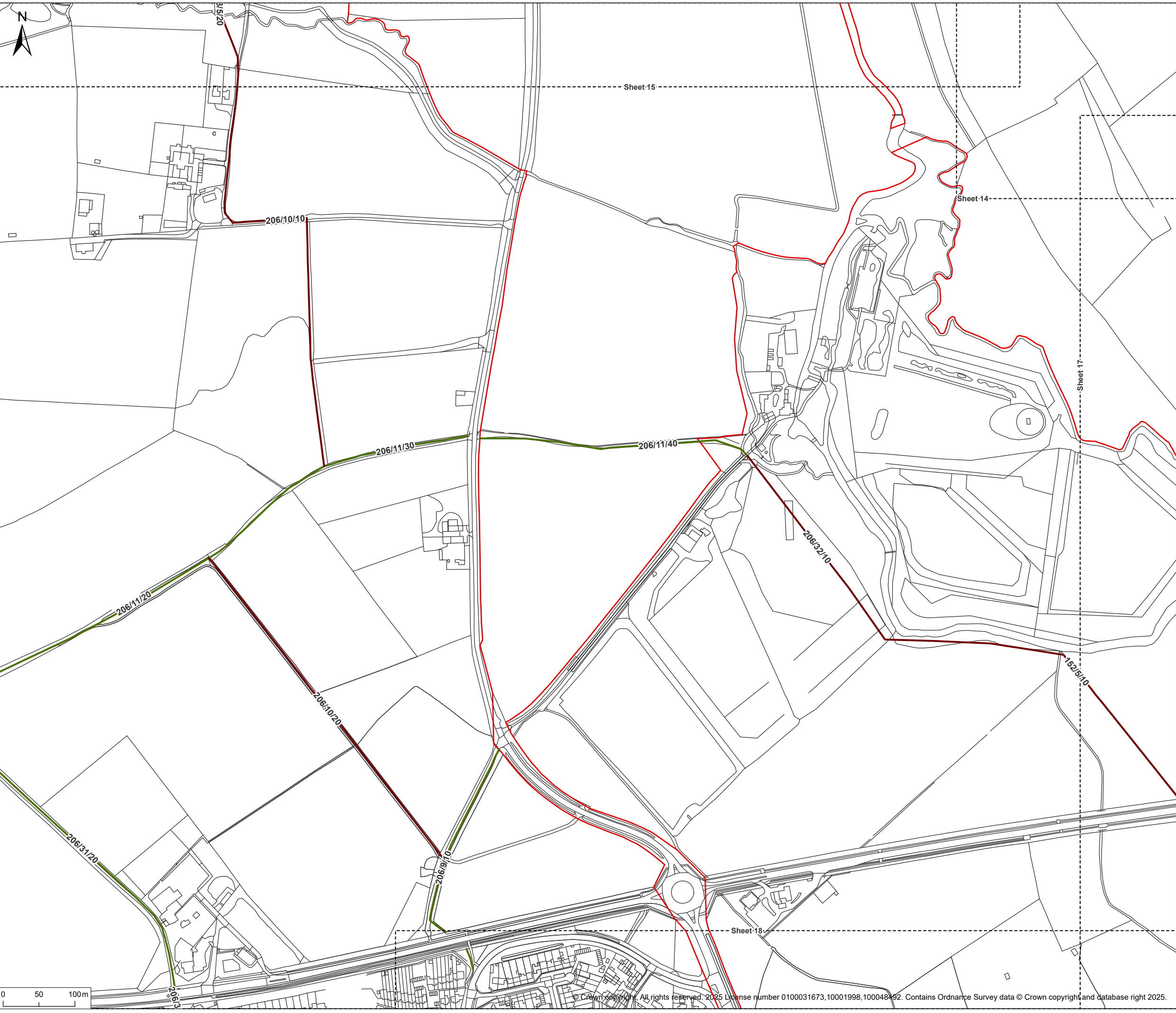

© 2025 RPS Group
 Notes
 1. This drawing has been prepared in accordance with the scope of RPS's appointment with its client and is subject to the terms and conditions of that appointment. RPS accepts no liability for any use of this document other than by its client and only for the purposes for which it was prepared and provided.
 2. If received electronically it is the recipients responsibility to print to correct scale. Only written dimensions should be used.

Legend

- Order Limits
- Public Rights of Way**
- Footpath
- Bridleway

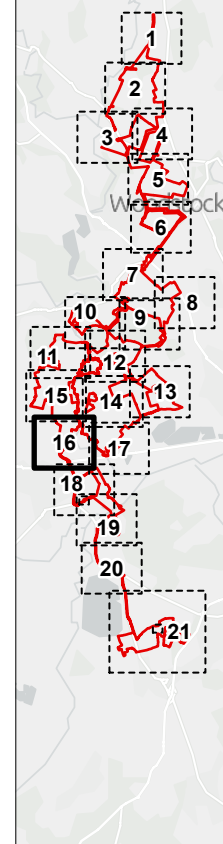

Rev	Description	By	CB	Date



PHOTOVOLT
DEVELOPMENT PARTNERS



RPS
A TETRA TECH COMPANY

Client **PVDP**

Project **Botley West Solar Farm**

Title **Appendix A: Location of outline PRoW management measures**

Status	Drawn By	PM/Checked By
FINAL	AC	BJ
Project Number	Scale @ A3	Date Created
NP12426	1:5,000	SEP 2025
Figure Number	Rev	
A16	03	

rpsgroup.com
 20 Western Avenue, Milton Park, Abingdon, Oxfordshire, OX14 4SH
 T: +44(0)1235 821 888 E: rps@rpsgroup.com

P:\eur-mpfs-02.eur.rpsgroup.com\Projects\12426 Proposed DCO Scale Solar Development 860mw\Tech\Drawings\12426-0222-03.aprx

P:\eur-mpfs-02.eur.rpsgroup.com\Projects\12426 Proposed DCO Scale Solar Development 860mw\Tech\Drawings\12426-0222-03.aprx

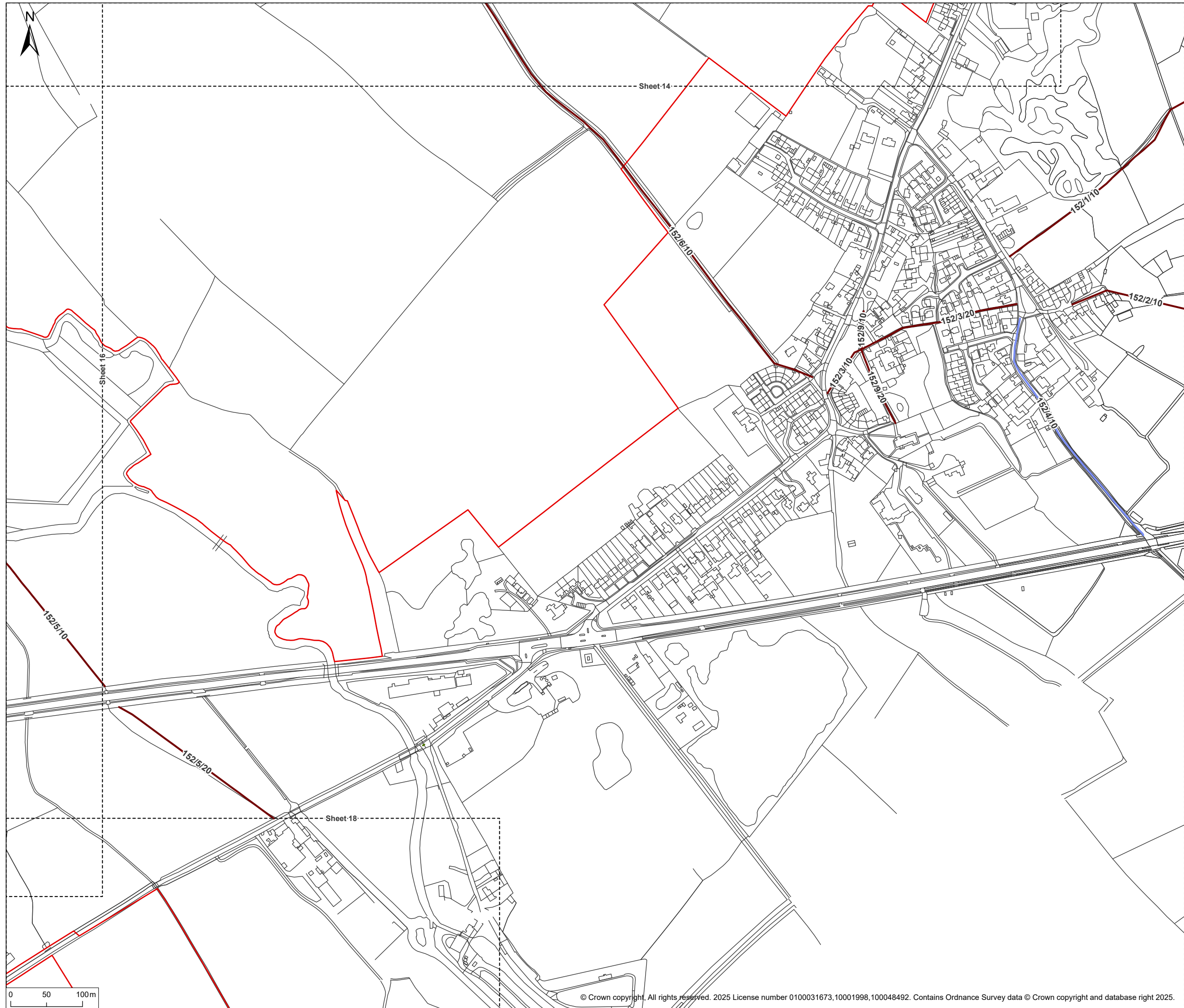

© 2025 RPS Group
Notes
1. This drawing has been prepared in accordance with the scope of RPS's appointment with its client and is subject to the terms and conditions of that appointment. RPS accepts no liability for any use of this document other than by its client and only for the purposes for which it was prepared and provided.
2. If received electronically it is the recipients responsibility to print to correct scale. Only written dimensions should be used.

Legend

- Order Limits
- Public Rights of Way**
- Footpath
- Bridleway
- Restricted byway

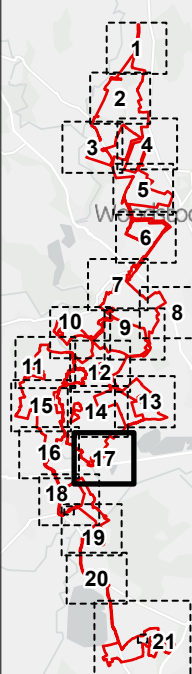

Rev	Description	By	CB	Date



PHOTOVOLT
DEVELOPMENT PARTNERS



rps
A TETRA TECH COMPANY

Client	PVDP		
Project	Botley West Solar Farm		
Title	Appendix A: Location of outline PRoW management measures		
Status	Drawn By	PM/Checked By	
FINAL	AC	BJ	
Project Number	Scale @ A3	Date Created	
NP12426	1:5,000	SEP 2025	
Figure Number		Rev	
A17		03	

rpsgroup.com
20 Western Avenue, Milton Park, Abingdon, Oxfordshire, OX14 4SH
T: +44(0)1235 821 888 E: rps@rpsgroup.com

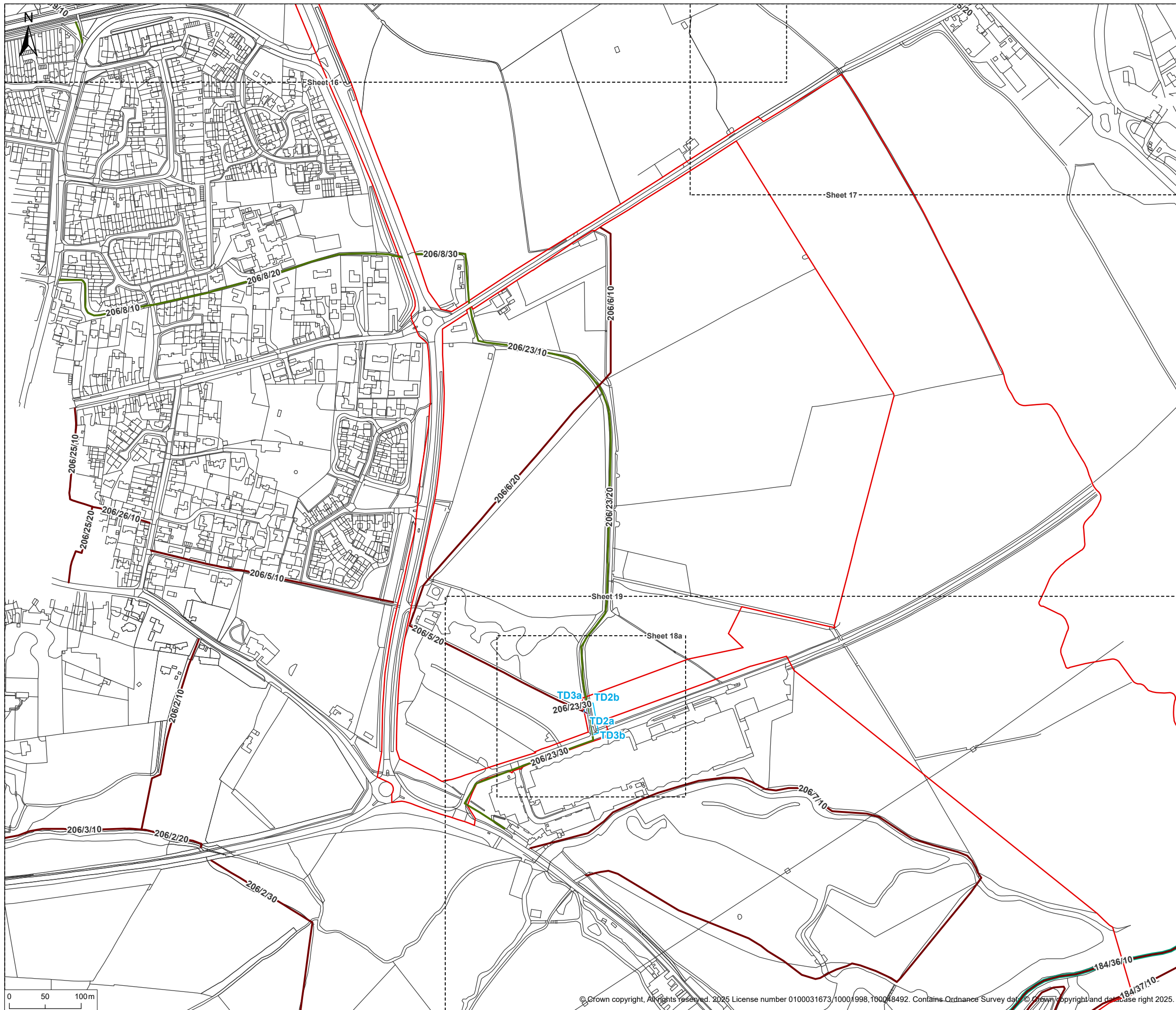

© 2025 RPS Group
 Notes
 1. This drawing has been prepared in accordance with the scope of RPS's appointment with its client and is subject to the terms and conditions of that appointment. RPS accepts no liability for any use of this document other than by its client and only for the purposes for which it was prepared and provided.
 2. If received electronically it is the recipients responsibility to print to correct scale. Only written dimensions should be used.

Legend

- Order Limits
- Public Rights of Way**

 - Footpath
 - Bridleway
 - Oxford Greenbelt Way

- Existing PRoWs to be Diverted**

 - - - Bridleway
 - - - Footpath

- Temporary Diversions**

 - - - Footpath
 - - - Bridleway

Rev	Description	By	CB	Date



PHOTOVOLT
DEVELOPMENT PARTNERS



RPS
A TETRA TECH COMPANY

Client **PVDP**

Project **Botley West Solar Farm**

Title **Appendix A: Location of outline PRoW management measures**

Status **FINAL** Drawn By **AC** PM/Checked By **BJ**

Project Number **NP12426** Scale @ A3 **1:5,000** Date Created **SEP 2025**

Figure Number **A18** Rev **03**

rpsgroup.com
 20 Western Avenue, Milton Park, Abingdon, Oxfordshire, OX14 4SH
 T: +44(0)1235 821 888 E: rps@rpsgroup.com

P:\eur-mpfs-02.eur.rpsgroup.com\Projects\12426 Proposed DCO Scale Solar Development 860mw\Tech\Drawings\12426-0222-03.aprx



© 2025 RPS Group
 Notes
 1. This drawing has been prepared in accordance with the scope of RPS's appointment with its client and is subject to the terms and conditions of that appointment. RPS accepts no liability for any use of this document other than by its client and only for the purposes for which it was prepared and provided.
 2. If received electronically it is the recipient's responsibility to print to correct scale. Only written dimensions should be used.

Legend

- Order Limits
- Public Rights of Way**
- Footpath
- Bridleway
- Existing PRow's to be Diverted**
- Bridleway
- Footpath
- Temporary Diversions**
- Footpath
- Bridleway

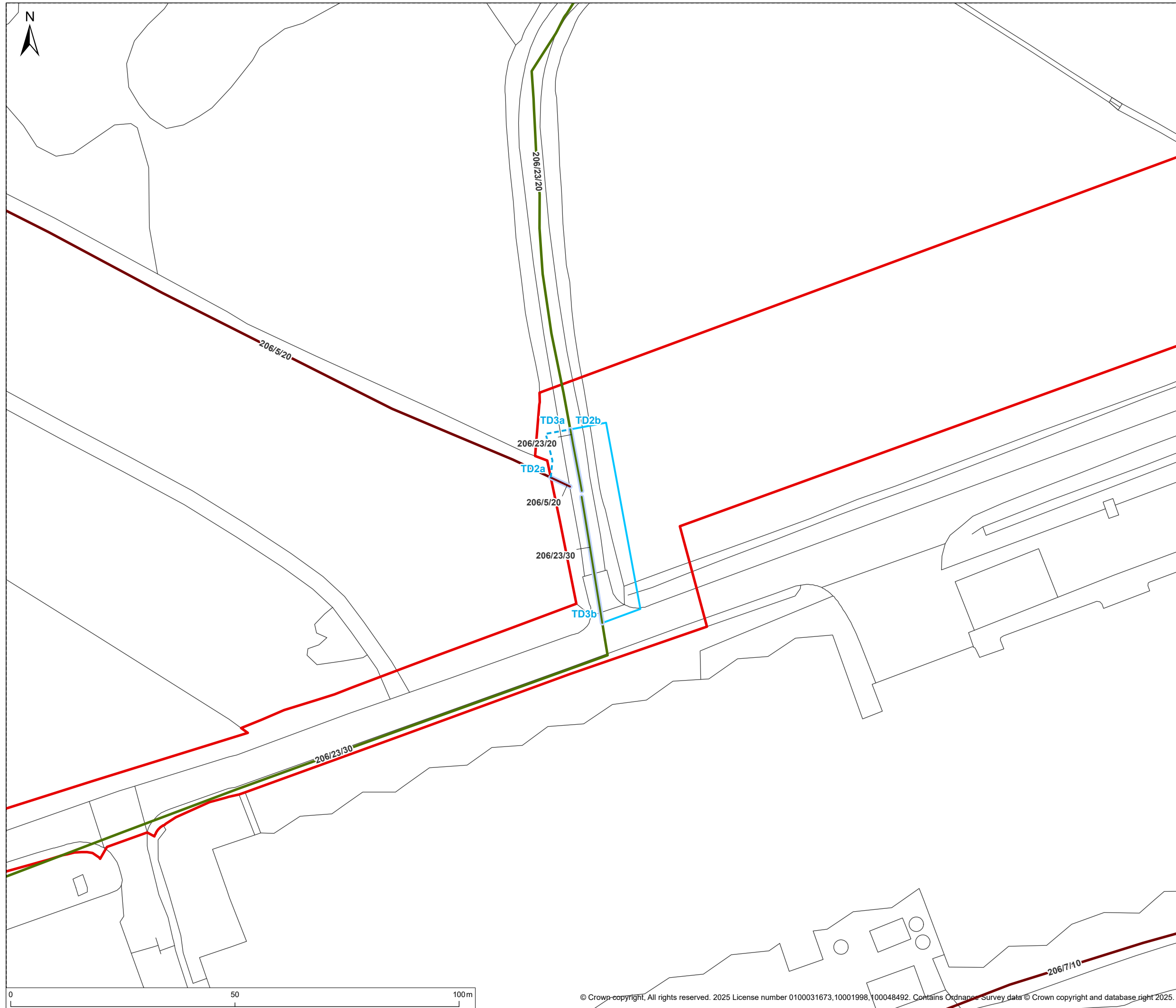

Rev	Description	By	CB	Date



PHOTOVOLT
DEVELOPMENT PARTNERS



RPS
A TETRA TECH COMPANY

Client **PVDP**

Project **Botley West Solar Farm**

Title **Appendix A: Location of outline PRow management measures**

Status	Drawn By	PM/Checked By
FINAL	AC	BJ
Project Number	Scale @ A3	Date Created
NP12426	1:800	SEP 2025
Figure Number		Rev
A18a		03

rpsgroup.com
 20 Western Avenue, Milton Park, Abingdon, Oxfordshire, OX14 4SH
 T: +44(0)1235 821 888 E: rps@rpsgroup.com

P:\eur-mpfs-02.eur.rpsgroup.com\Projects\12426 Proposed DCO Scale Solar Development 860mw\Tech\Drawings\12426-0222-03.aprx

P:\eur-mpfs-02.eur.rpsgroup.com\Projects\12426 Proposed DCO Scale Solar Development 860mw\Tech\Drawings\12426-0222-03.aprx

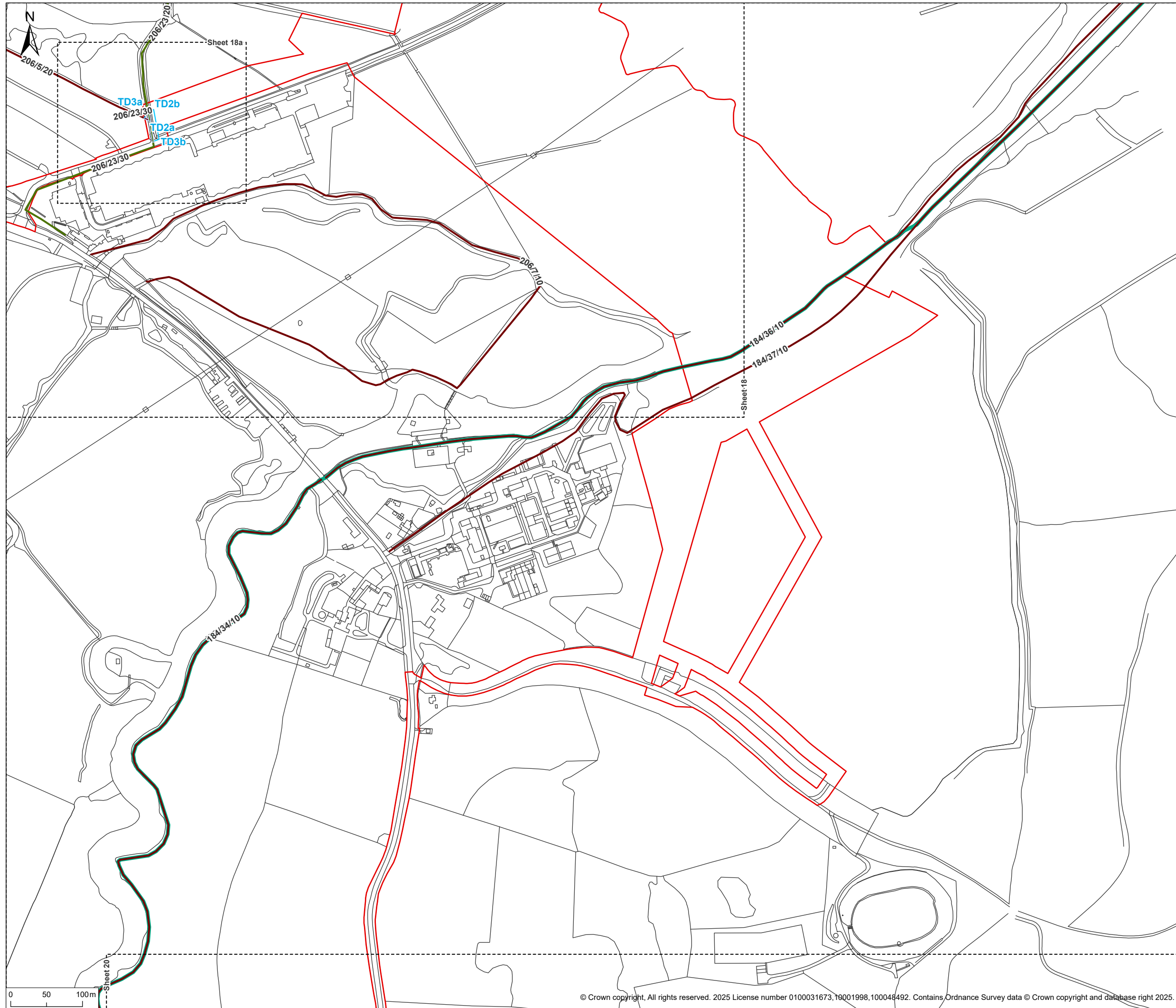

© 2025 RPS Group
 Notes
 1. This drawing has been prepared in accordance with the scope of RPS's appointment with its client and is subject to the terms and conditions of that appointment. RPS accepts no liability for any use of this document other than by its client and only for the purposes for which it was prepared and provided.
 2. If received electronically it is the recipients responsibility to print to correct scale. Only written dimensions should be used.

Legend

- Order Limits
- Public Rights of Way**
- Footpath
- Bridleway
- Oxford Greenbelt Way
- Existing PRoWs to be Diverted**
- Bridleway
- Footpath
- Temporary Diversions**
- Footpath
- Bridleway

Rev	Description	By	CB	Date



PHOTOVOLT
DEVELOPMENT PARTNERS



rps
A TETRA TECH COMPANY

Client **PVDP**

Project **Botley West Solar Farm**

Title **Appendix A: Location of outline PRoW management measures**

Status **FINAL** Drawn By **AC** PM/Checked By **BJ**

Project Number **NP12426** Scale @ A3 **1:5,000** Date Created **SEP 2025**

Figure Number **A19** Rev **03**

rpsgroup.com
 20 Western Avenue, Milton Park, Abingdon, Oxfordshire, OX14 4SH
 T: +44(0)1235 821 888 E: rps@rpsgroup.com

P:\eur-mpfs-02.eur.rpsgroup.com\Projects\12426 Proposed DCO Scale Solar Development 860mw\Tech\Drawings\12426-0222-03.aprx

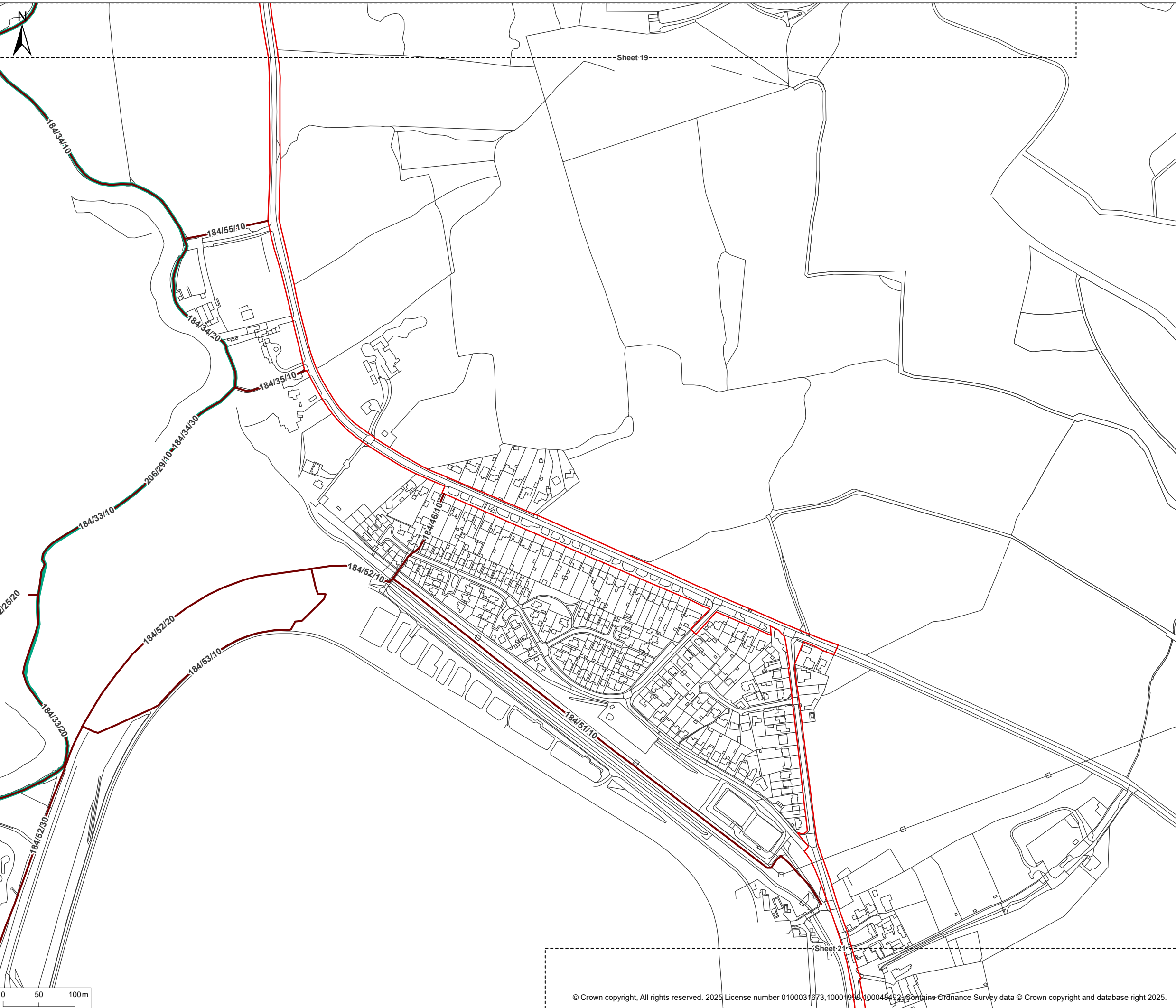

Sheet 19

Sheet 21

© 2025 RPS Group
Notes
1. This drawing has been prepared in accordance with the scope of RPS's appointment with its client and is subject to the terms and conditions of that appointment. RPS accepts no liability for any use of this document other than by its client and only for the purposes for which it was prepared and provided.
2. If received electronically it is the recipients responsibility to print to correct scale. Only written dimensions should be used.

Legend

- Order Limits
- Public Rights of Way**
- Footpath
- Oxford Greenbelt Way

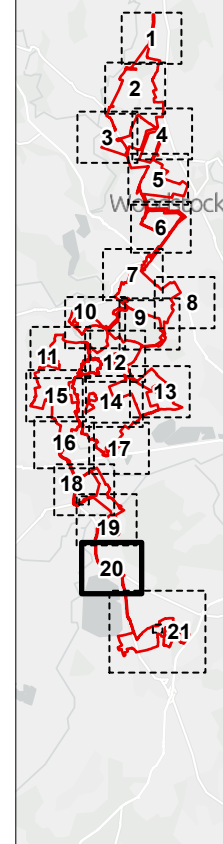

Rev	Description	By	CB	Date



PHOTOVOLT
DEVELOPMENT PARTNERS



rps
A TETRA TECH COMPANY

Client **PVDP**

Project **Botley West Solar Farm**

Title **Appendix A: Location of outline PRoW management measures**

Status **FINAL** Drawn By **AC** PM/Checked By **BJ**

Project Number **NP12426** Scale @ A3 **1:5,000** Date Created **SEP 2025**

Figure Number **A20** Rev **03**

rpsgroup.com
20 Western Avenue, Milton Park, Abingdon, Oxfordshire, OX14 4SH
T: +44(0)1235 821 888 E: rpsxo@rpsgroup.com

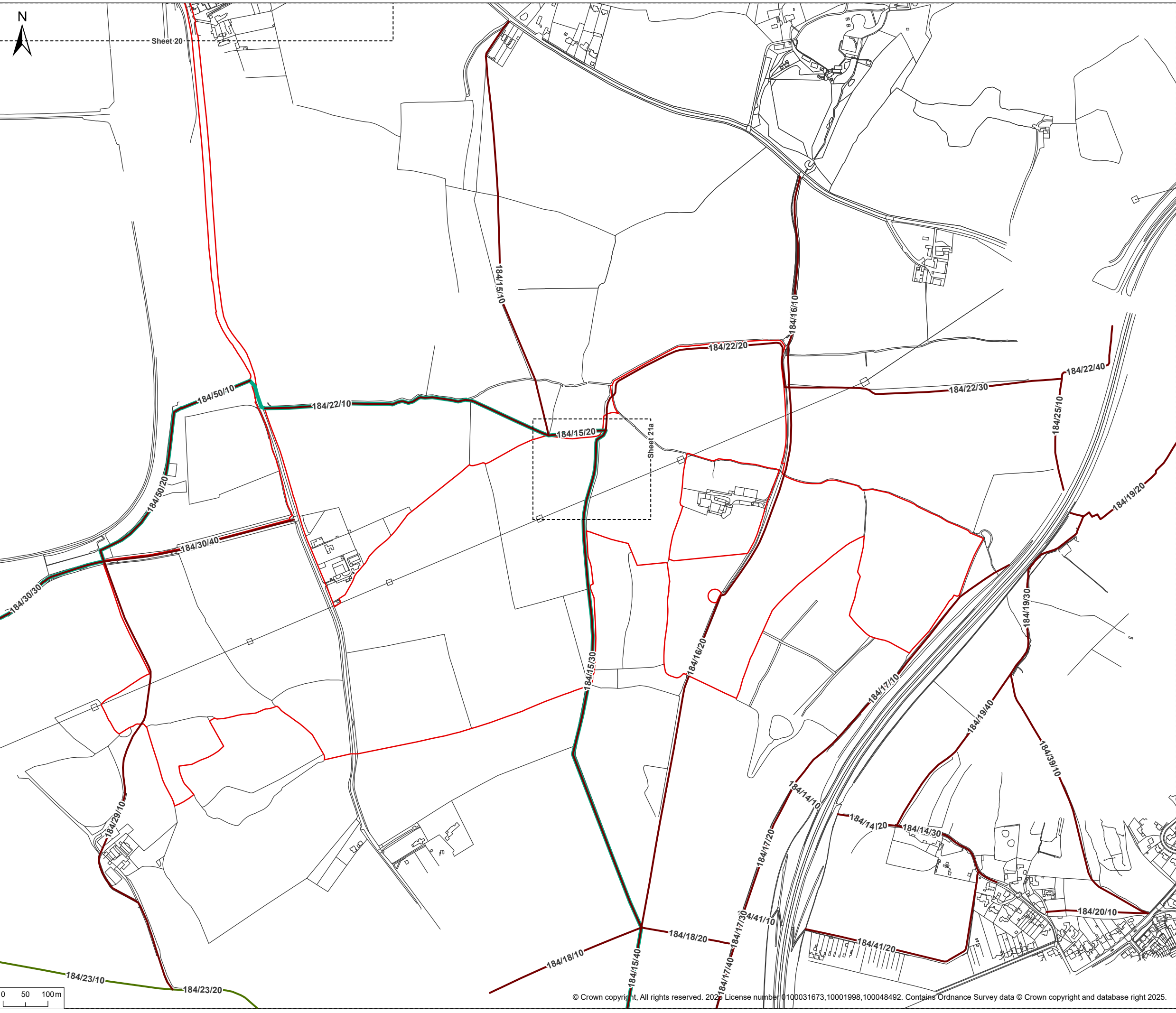

Sheet 20

Sheet 21a

© 2025 RPS Group
 Notes
 1. This drawing has been prepared in accordance with the scope of RPS's appointment with its client and is subject to the terms and conditions of that appointment. RPS accepts no liability for any use of this document other than by its client and only for the purposes for which it was prepared and provided.
 2. If received electronically it is the recipients responsibility to print to correct scale. Only written dimensions should be used.

- Legend**
- Order Limits
 - Public Rights of Way**
 - Footpath
 - Bridleway
 - Oxford Greenbelt Way

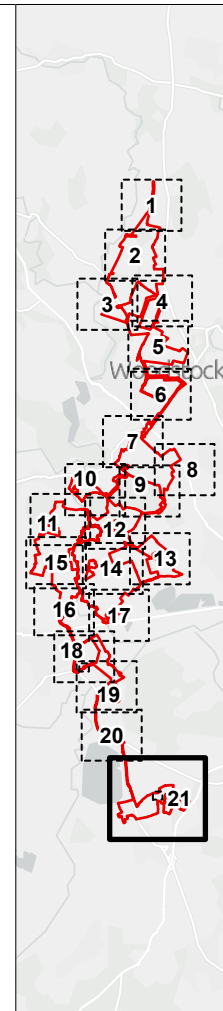

Rev	Description	By	CB	Date



PHOTOVOLT
DEVELOPMENT PARTNERS



RPS
A TETRA TECH COMPANY

Client PVDP

Project Botley West Solar Farm

Title Appendix A: Location of outline PRoW management measures

Status **FINAL** Drawn By AC PM/Checked By BJ

Project Number NP12426 Scale @ A3 1:8,000 Date Created SEP 2025

Figure Number **A21** Rev **03**

rpsgroup.com
 20 Western Avenue, Milton Park, Abingdon, Oxfordshire, OX14 4SH
 T: +44(0)1235 821 888 E: rps@rpsgroup.com

P:\eur-mpfs-02.eur.rpsgroup.com\Projects\12426 Proposed DCO Scale Solar Development 860mw\Tech\Drawings\12426-0222-03.aprx

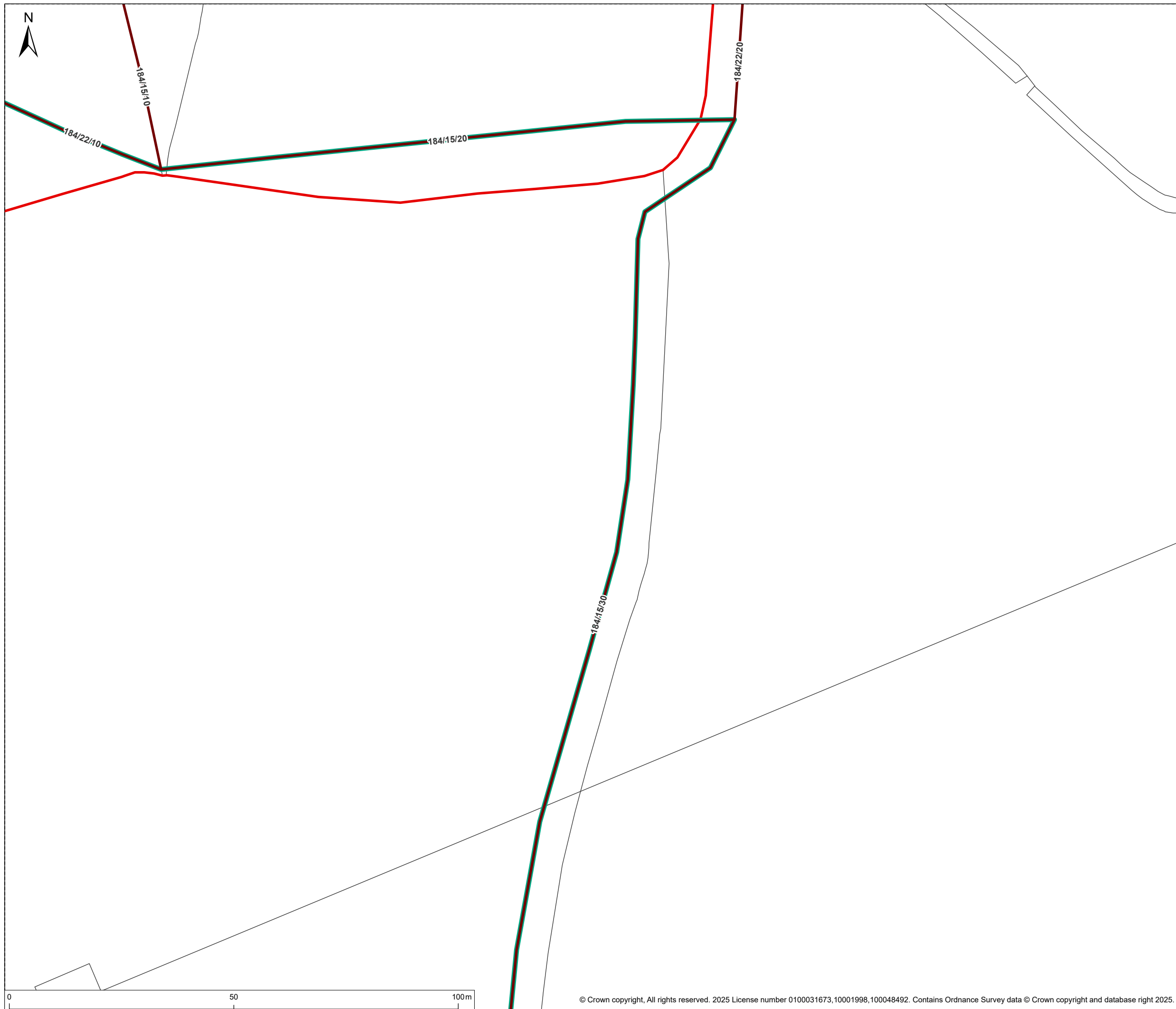



© 2025 RPS Group

Notes

1. This drawing has been prepared in accordance with the scope of RPS's appointment with its client and is subject to the terms and conditions of that appointment. RPS accepts no liability for any use of this document other than by its client and only for the purposes for which it was prepared and provided.
2. If received electronically it is the recipients responsibility to print to correct scale. Only written dimensions should be used.

Legend

-  Order Limits
- Public Rights of Way**
-  Footpath
-  Oxford Greenbelt Way

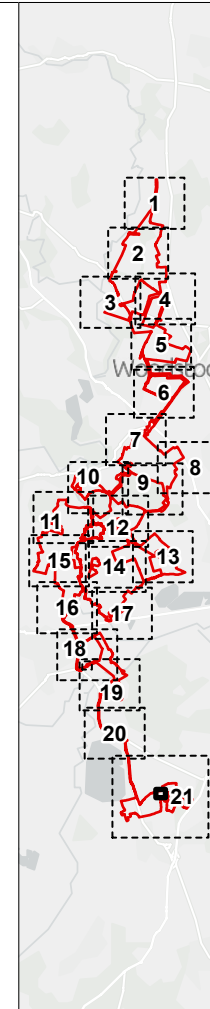

Rev	Description	By	CB	Date



PHOTOVOLT
DEVELOPMENT PARTNERS



RPS
A TETRA TECH COMPANY

Client **PVDP**

Project **Botley West Solar Farm**

Title **Appendix A: Location of outline PRoW management measures**

Status	Drawn By	PM/Checked By
FINAL	AC	BJ
Project Number	Scale @ A3	Date Created
NP12426	1:800	SEP 2025
Figure Number	Rev	
A21a	03	

rpsgroup.com
 20 Western Avenue, Milton Park, Abingdon, Oxfordshire, OX14 4SH
 T: +44(0)1235 821 888 E: rps@rpsgroup.com

P:\eur-mpfs-02.eur.rpsgroup.com\Projects\12426 Proposed DCO Scale Solar Development 860mw\Tech\Drawings\12426-0222-03.aprx

Appendix B

PRoW User Surveys

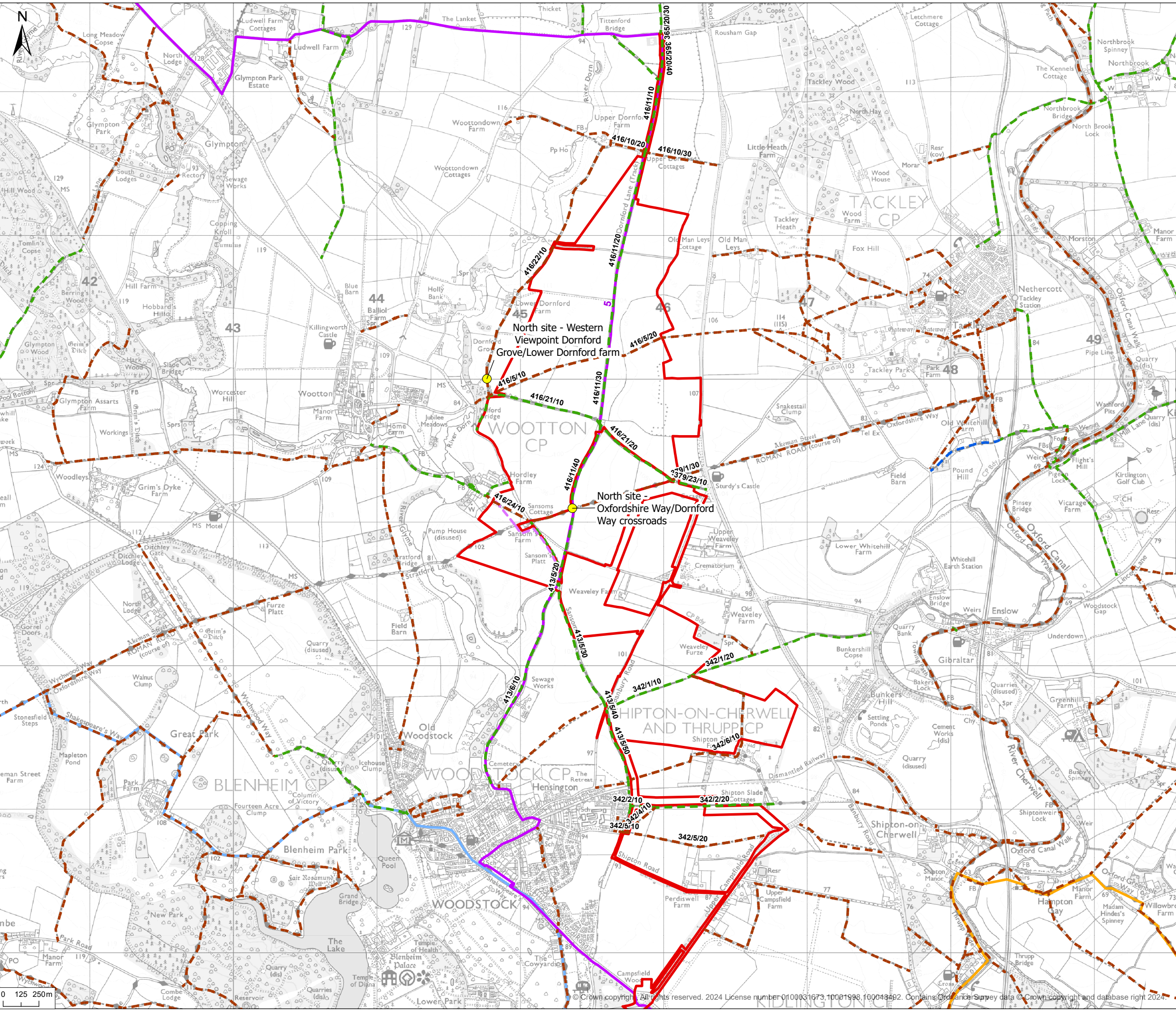

© 2024 RPS Group
 Notes
 1. This drawing has been prepared in accordance with the scope of RPS's appointment with its client and is subject to the terms and conditions of that appointment. RPS accepts no liability for any use of this document other than by its client and only for the purposes for which it was prepared and provided.
 2. If received electronically it is the recipient's responsibility to print to correct scale. Only written dimensions should be used.

- Legend**
- Order Limits
 - PRoW User Survey Locations
 - Proposed Cycle Path
 - Oxford Greenbelt Way
 - National Cycle Network
 - Shakespeare Way
 - Public Rights of Way
 - Bridleway
 - Footpath
 - Restricted Byway

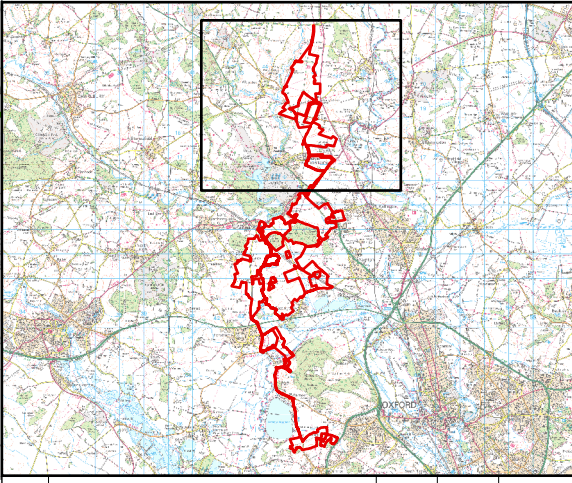

Rev	Description	By	CB	Date

PHOTOVOLT
DEVELOPMENT PARTNERS

Client PVDP
 Project Botley West Solar Farm
 Title PRoW User Survey Locations
 Status FINAL
 Drawing Number EN010147/APP/6.4
 Figure Number 17.5

Drawn By JM
 Scale @ A3 1:25,000

PM/Checked By CL
 Date Created NOV 2024
 Rev -

rpsgroup.com
 20 Western Avenue, Milton Park, Abingdon, Oxfordshire, OX14 4SH
 T: +44(0)1235 821 888 E: rps@rpsgroup.com

P:\eur-mpfs-02.eur.rpsgroup.com\Projects\12426 Proposed DCO Scale Solar Development 860mw\Tech\Drawings\12426-0220-01.aprx

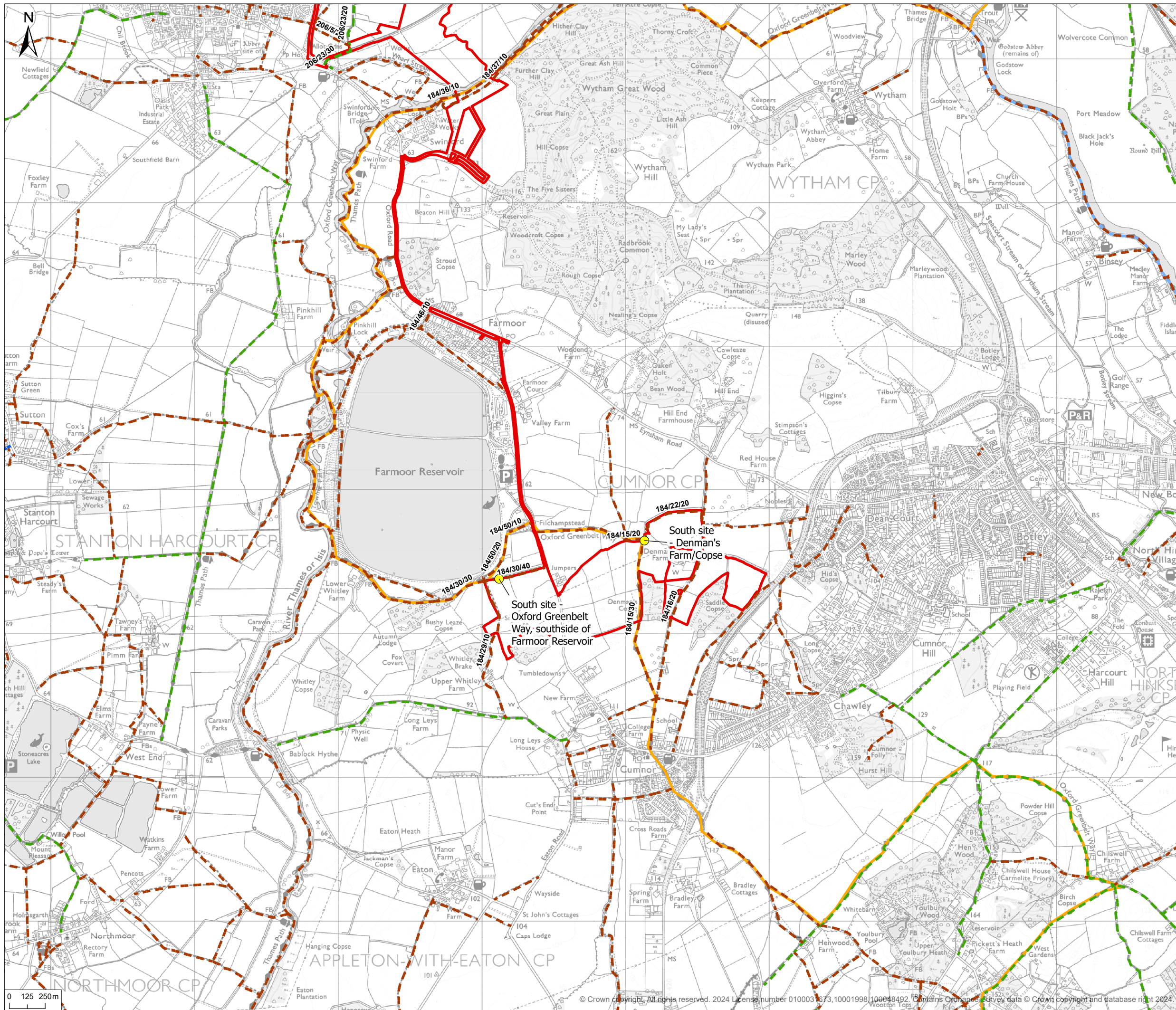

© 2024 RPS Group
 Notes
 1. This drawing has been prepared in accordance with the scope of RPS's appointment with its client and is subject to the terms and conditions of that appointment. RPS accepts no liability for any use of this document other than by its client and only for the purposes for which it was prepared and provided.
 2. If received electronically it is the recipient's responsibility to print to correct scale. Only written dimensions should be used.

- Legend**
- Order Limits
 - PRoW User Survey Locations
 - Oxford Greenbelt Way
 - National Cycle Network
 - Shakespeare Way
- Public Rights of Way**
- - - Bridleway
 - - - Footpath
 - - - Restricted Byway

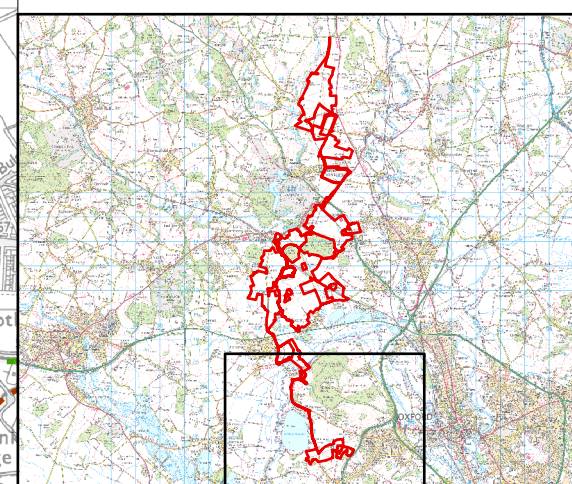

Rev	Description	By	CB	Date



PHOTOVOLT
DEVELOPMENT PARTNERS



A TETRA TECH COMPANY

Client	PVDP		
Project	Botley West Solar Farm		
Title	PRoW User Survey Locations		
Status	Drawn By	PM/Checked By	
FINAL	JM	CL	
Drawing Number	Scale @ A3	Date Created	
EN010147/APP/6.4	1:25,000	NOV 2024	
Figure Number	Rev		
17.5	-		

rpsgroup.com
 20 Western Avenue, Milton Park, Abingdon, Oxfordshire, OX14 4SH
 T: +44(0)1235 821 888 E: rps@rpsgroup.com

P:\e-ur-rpsgroup.com\Projects\12426 Proposed DCO Scale Solar Development 860mwi\TechDrawings\12426-0220-01.aprx

0 125 250m

© Crown copyright. All rights reserved. 2024 License number 010003 673,10001998,100048492. Contains Ordnance Survey data © Crown copyright and database right 2024.

PRoW Botley Farm Survey

Overall 451 respondents took part in the PRoW Botley Farm Survey across three dates in summer 2024 to ensure a wide range of residents and visitors were interviewed. Fieldwork took place on Saturday 13th July, Wednesday 24th July and Monday 26th August between 7:00am and 7:00pm. The breakdown of interviews done on each date is shown in the first chart of this report.

This report shows the overall results to the closed questions. For any open-ended responses, please refer to the raw data.

Date of interview

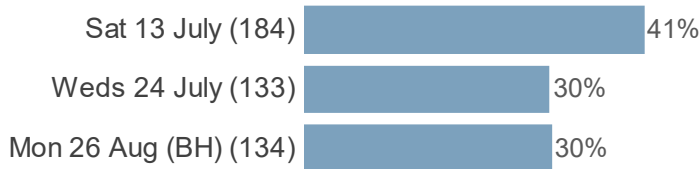

Interviewing location

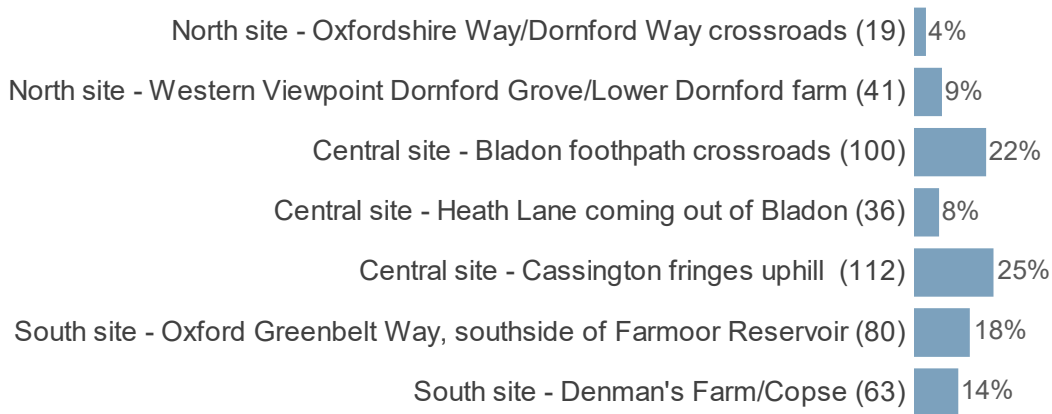

Weather conditions



Q1. Are you a resident of the area, or are you a visitor?



PRoW Botley Farm Survey

Q2. What is the main reason you are here today?

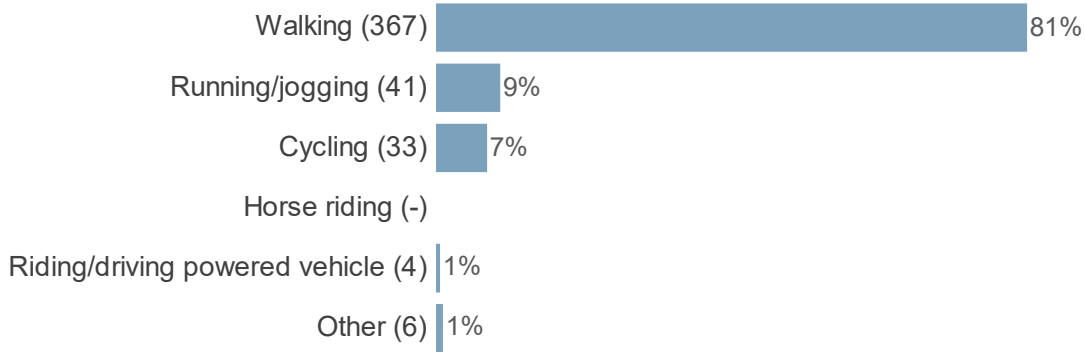

Q3. How long will you spend on this activity here today?

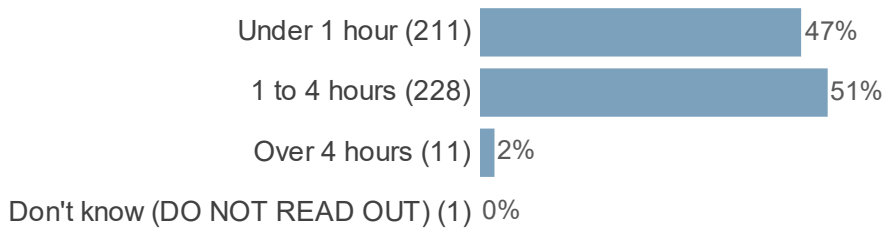

Q6. How often do you use this route?

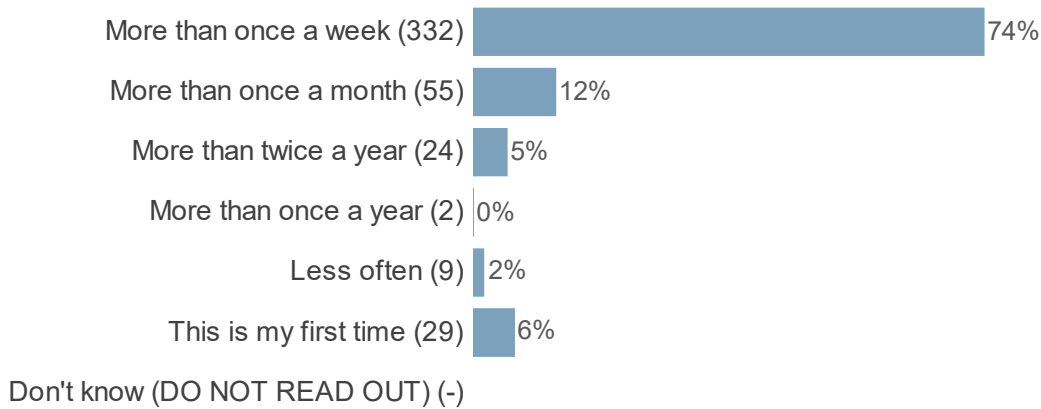

PRoW Botley Farm Survey

Q7. How far away from here do you live?

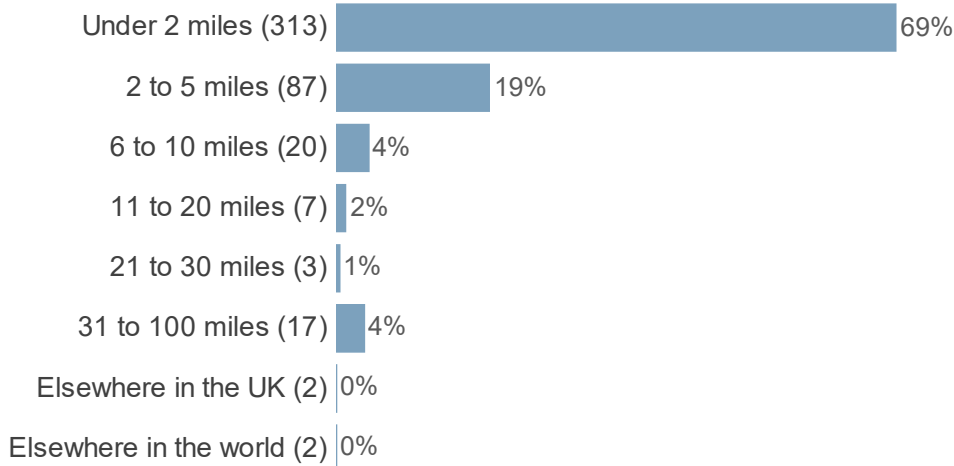

Q8. Did you select this route due to any particular mobility or access needs?



Q9. How many people are you here with, including yourself?

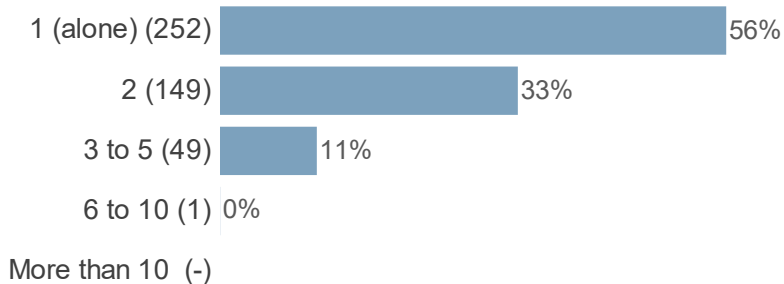

Q10. Do you have any dogs with you today?



Q11. I'm going to read out some broad age ranges. Please let me know which age group you (or anyone in your group) falls into



PRoW Botley Farm Survey

Q12. Do you (or anyone in your group) have any of the following with you today?

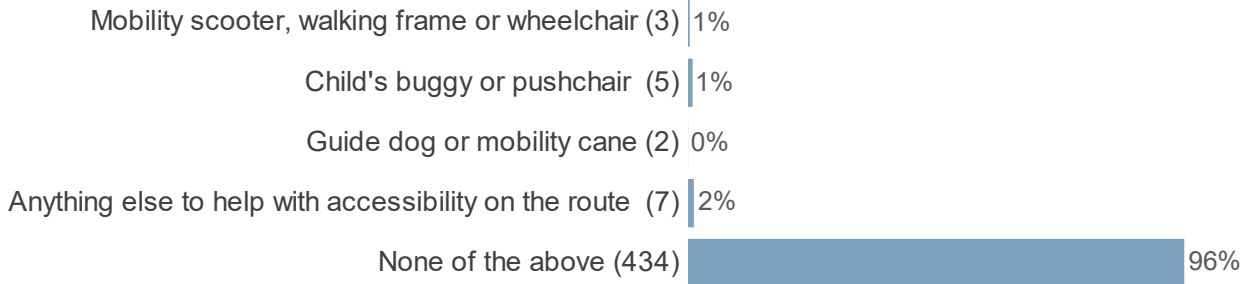

Q13. Nature of the party

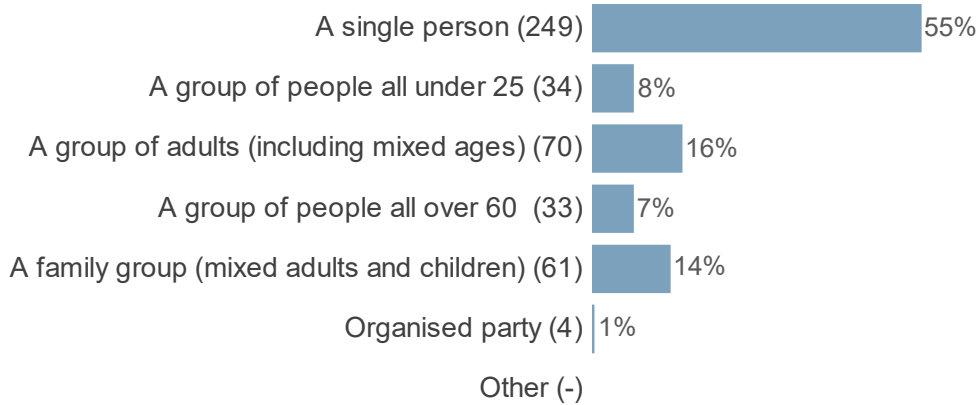

PRoW Botley Farm Survey

Overall 184 respondents took part in the PRoW Botley Farm Survey on Saturday 13th July 2024.

This report shows the overall results to the closed questions. For any open-ended responses, please refer to the raw data.

Interviewing location



Weather conditions



Q1. Are you a resident of the area, or are you a visitor?



Q2. What is the main reason you are here today?

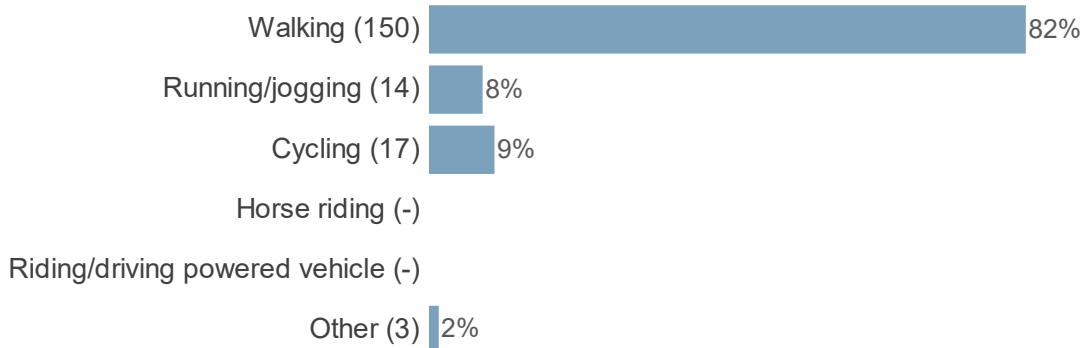

PRoW Botley Farm Survey

Q3. How long will you spend on this activity here today?

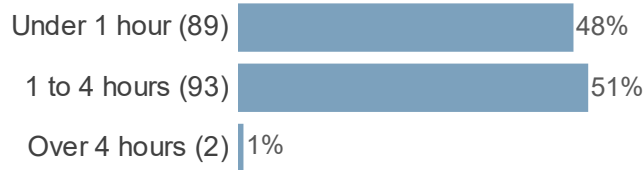

Don't know (DO NOT READ OUT) (-)

Q6. How often do you use this route?

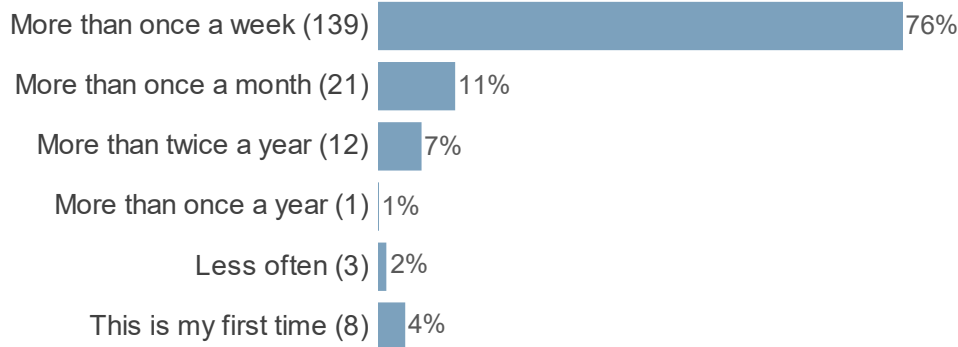

Don't know (DO NOT READ OUT) (-)

Q7. How far away from here do you live?

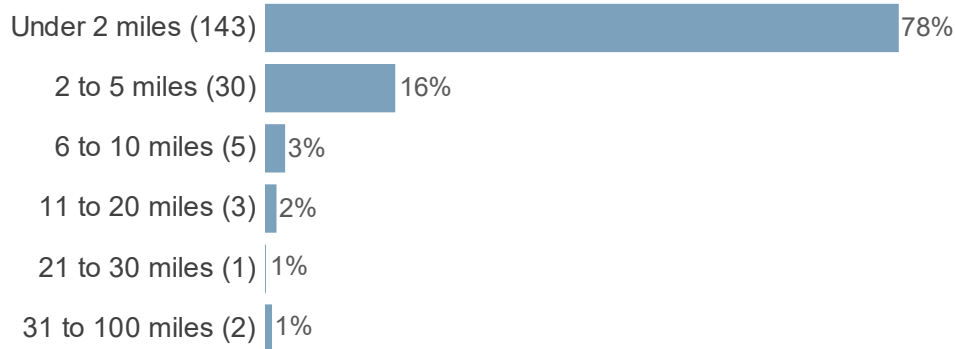

Elsewhere in the UK (-)

Elsewhere in the world (-)

Q8. Did you select this route due to any particular mobility or access needs?



PRoW Botley Farm Survey

Q9. How many people are you here with, including yourself?

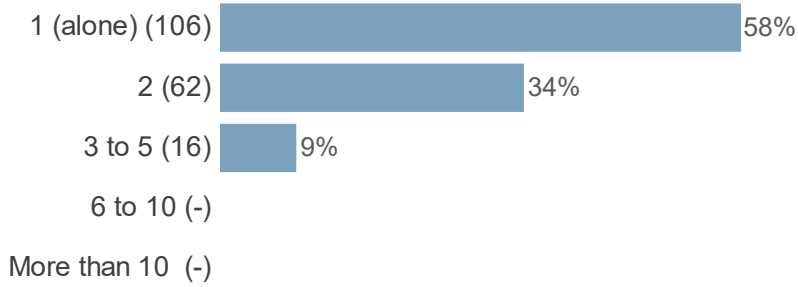

Q10. Do you have any dogs with you today?



Q11. I'm going to read out some broad age ranges. Please let me know which age group you (or anyone in your group) falls into



Q12. Do you (or anyone in your group) have any of the following with you today?

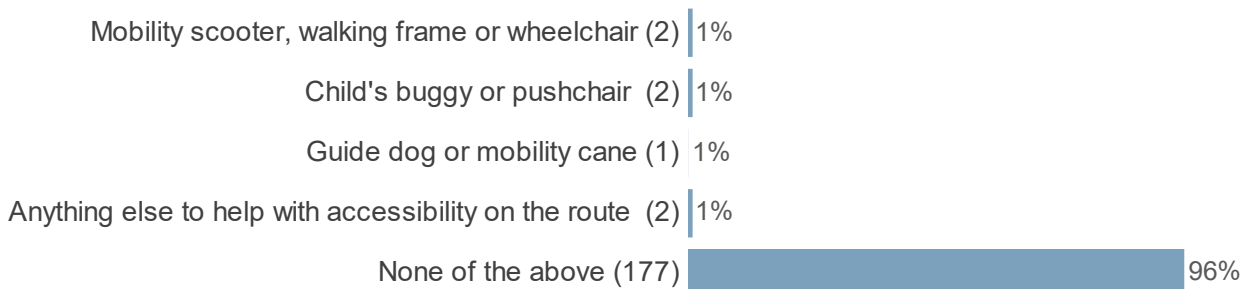

PRoW Botley Farm Survey

Q13. Nature of the party

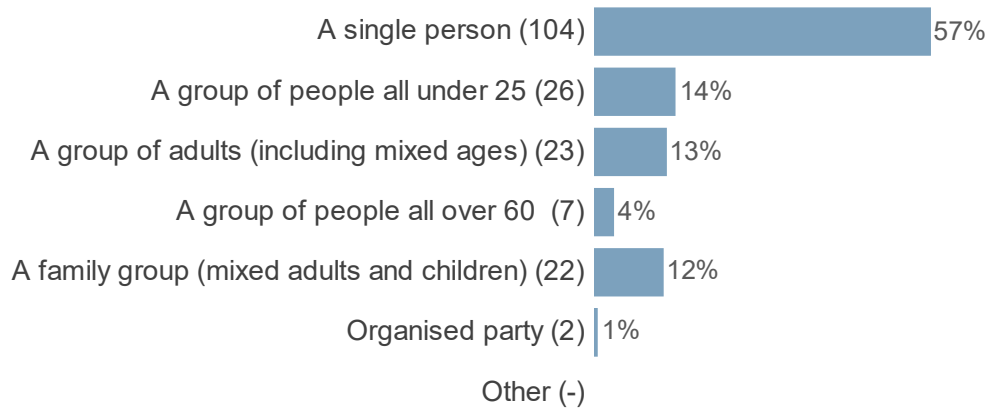

PRoW Botley Farm Survey

Overall 133 respondents took part in the PRoW Botley Farm Survey on Wednesday 24th July 2024.

This report shows the overall results to the closed questions. For any open-ended responses, please refer to the raw data.

Interviewing location

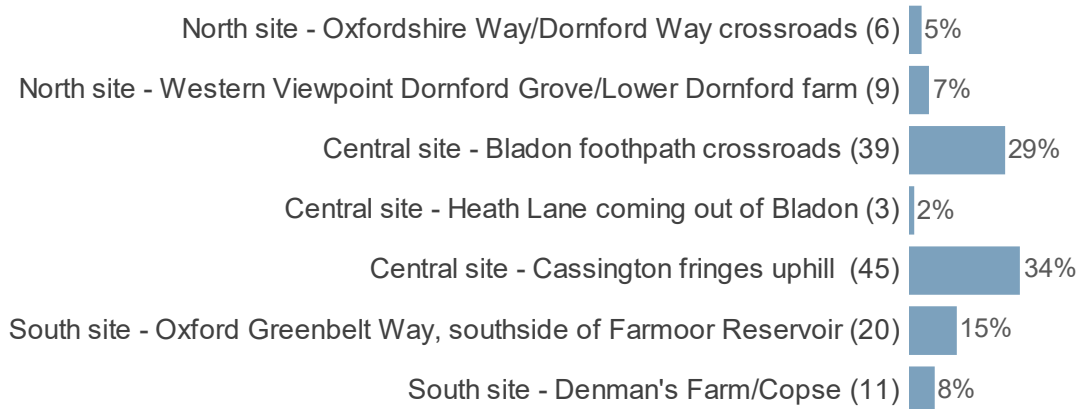

Weather conditions



Q1. Are you a resident of the area, or are you a visitor?



Q2. What is the main reason you are here today?

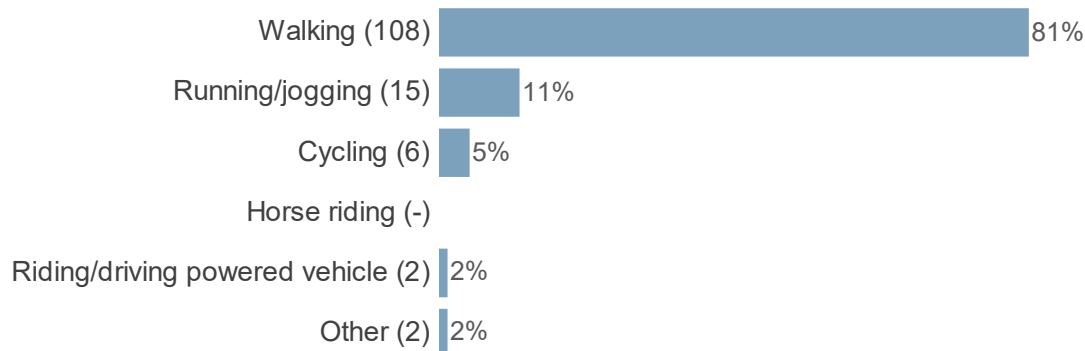

PRoW Botley Farm Survey

Q3. How long will you spend on this activity here today?

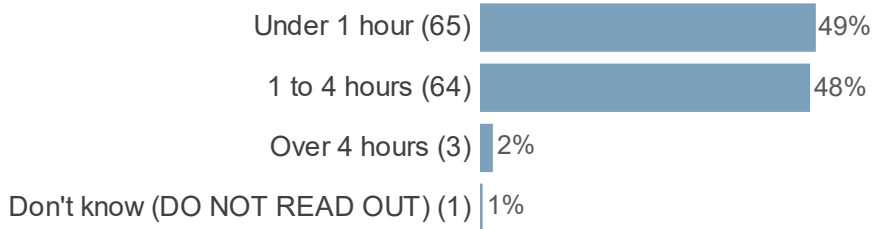

Q6. How often do you use this route?

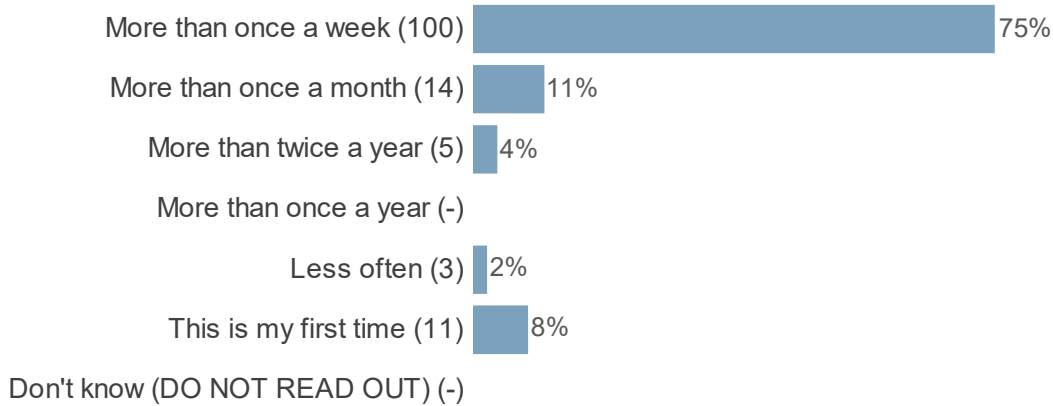

Q7. How far away from here do you live?

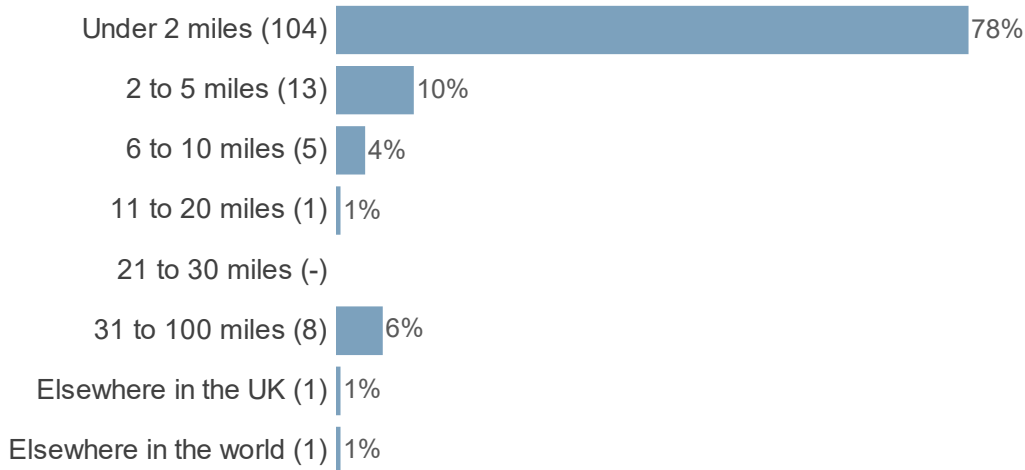

Q8. Did you select this route due to any particular mobility or access needs?



PRoW Botley Farm Survey

Q9. How many people are you here with, including yourself?

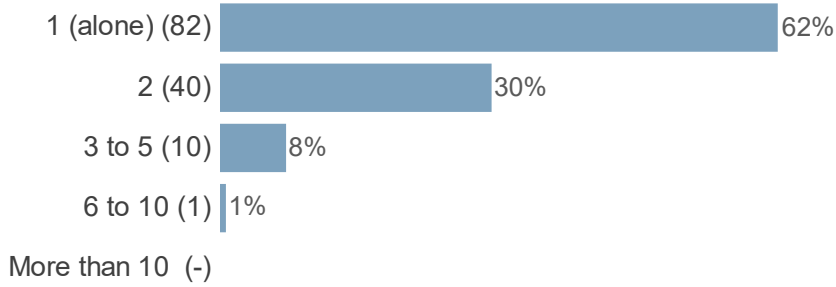

Q10. Do you have any dogs with you today?



Q11. I'm going to read out some broad age ranges. Please let me know which age group you (or anyone in your group) falls into



Q12. Do you (or anyone in your group) have any of the following with you today?

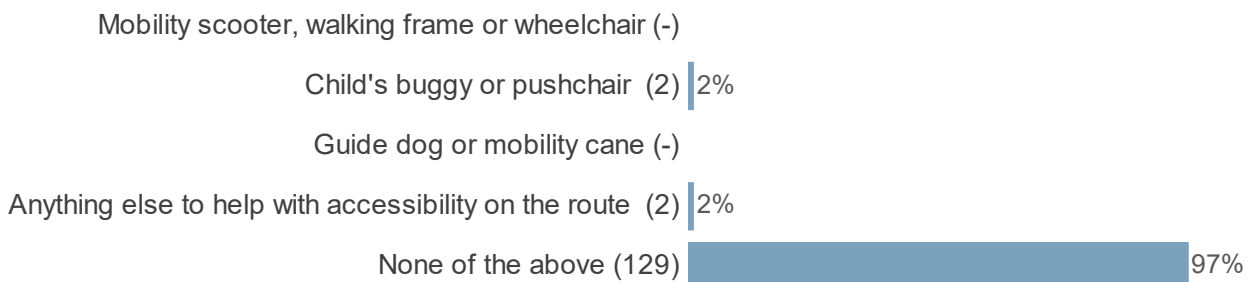

PRoW Botley Farm Survey

Q13. Nature of the party

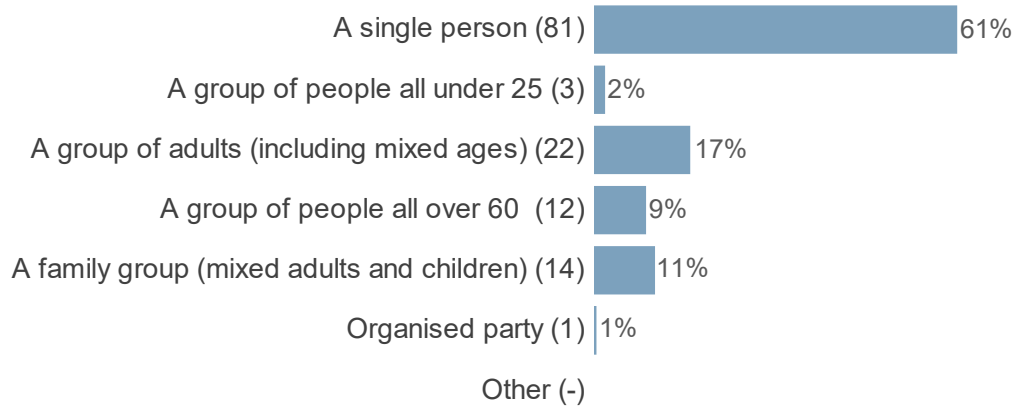

PRoW Botley Farm Survey

Overall 134 respondents took part in the PRoW Botley Farm Survey on Monday 26th August 2024.

This report shows the overall results to the closed questions. For any open-ended responses, please refer to the raw data.

Interviewing location

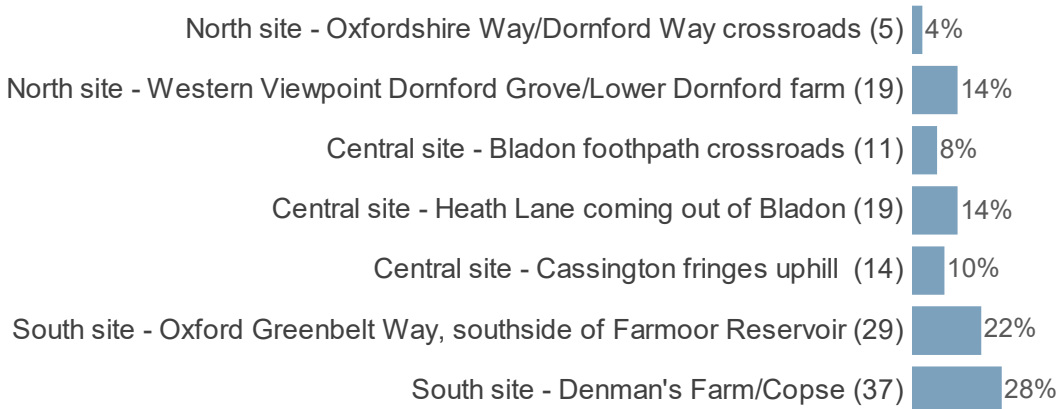

Weather conditions



Q1. Are you a resident of the area, or are you a visitor?



Q2. What is the main reason you are here today?

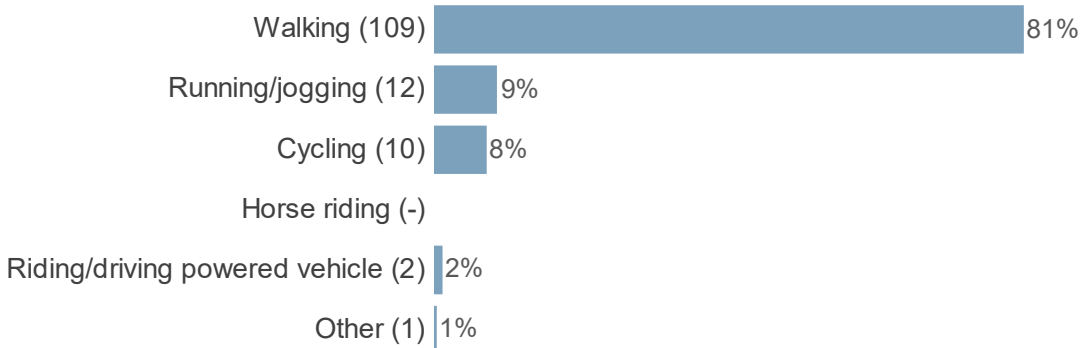

PRoW Botley Farm Survey

Q3. How long will you spend on this activity here today?

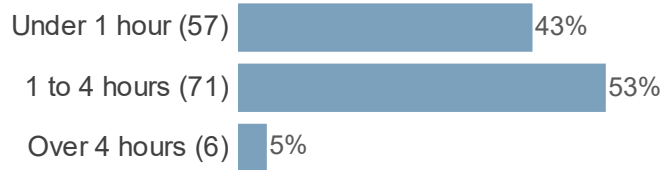

Don't know (DO NOT READ OUT) (-)

Q6. How often do you use this route?

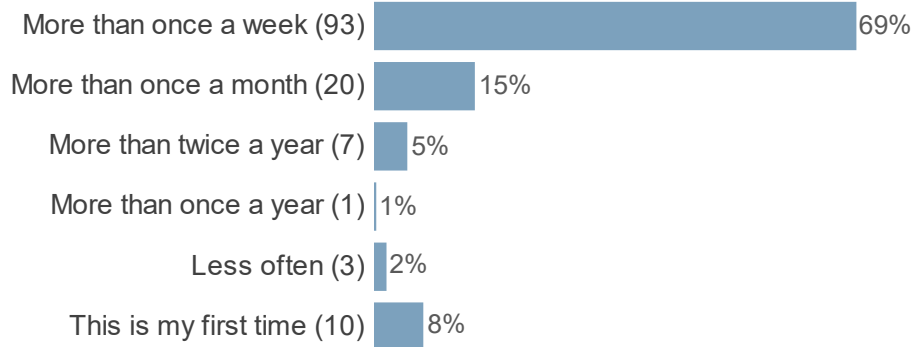

Don't know (DO NOT READ OUT) (-)

Q7. How far away from here do you live?

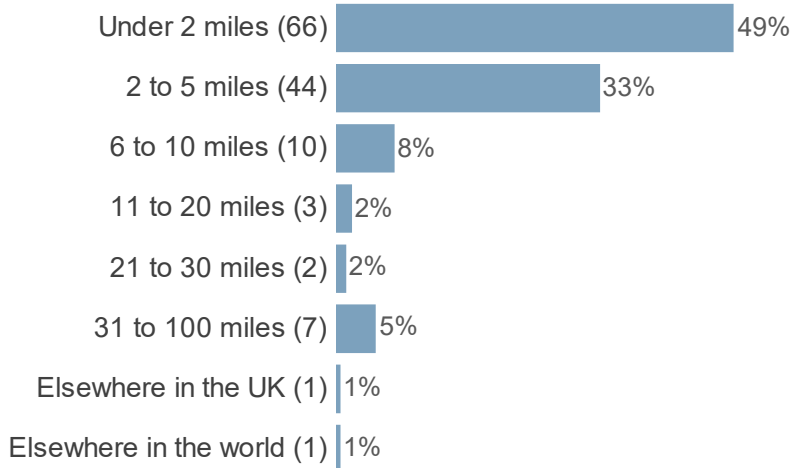

Q8. Did you select this route due to any particular mobility or access needs?



PRoW Botley Farm Survey

Q9. How many people are you here with, including yourself?

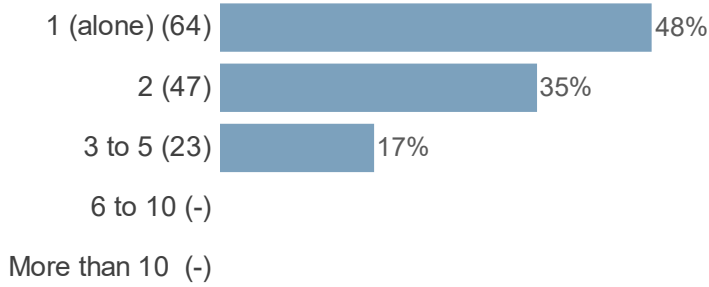

Q10. Do you have any dogs with you today?



Q11. I'm going to read out some broad age ranges. Please let me know which age group you (or anyone in your group) falls into

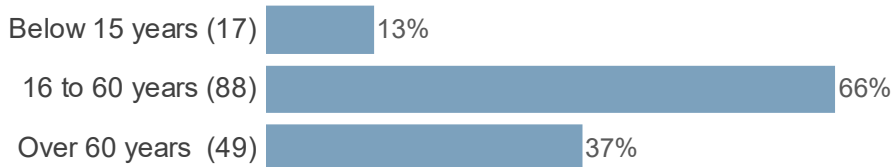

Q12. Do you (or anyone in your group) have any of the following with you today?

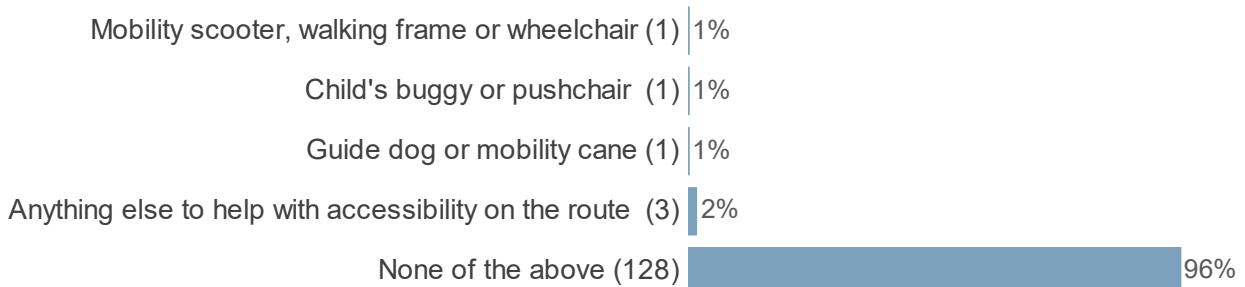

PRoW Botley Farm Survey

Q13. Nature of the party

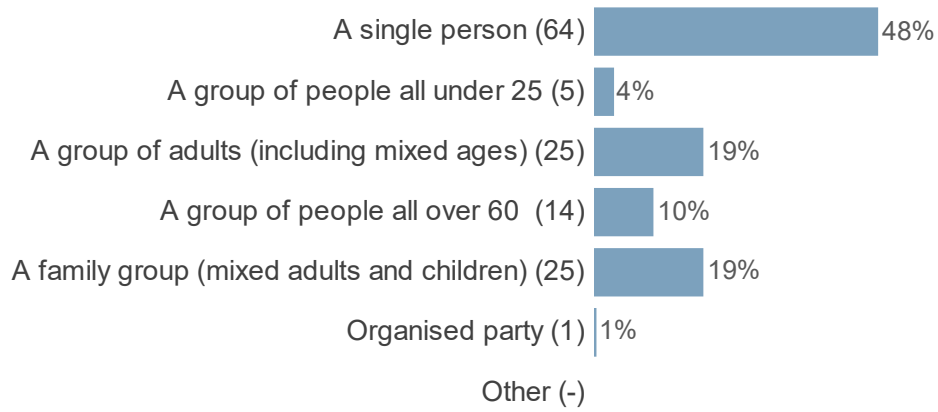

Annex C

Outline Soil Management Plan



Botley West Solar Farm

Outline Soil Management Plan

June 2026

Approval for issue

Amy Robinson

9 June 2026

The report has been prepared for the exclusive use and benefit of the Applicant and solely for the purpose for which it is provided. Unless otherwise agreed in writing by RPS Group Plc, any of its subsidiaries, or a related entity (collectively 'RPS') no part of this report should be reproduced, distributed or communicated to any third party. RPS does not accept any liability if this report is used for an alternative purpose from which it is intended, nor to any third party in respect of this report. The report does not account for any changes relating to the subject matter of the report, or any legislative or regulatory changes that have occurred since the report was produced and that may affect the report.

The report has been prepared using the information provided to RPS by its client, or others on behalf of its client. To the fullest extent permitted by law, RPS shall not be liable for any loss or damage suffered by the client arising from fraud, misrepresentation, withholding of information material relevant to the report or required by RPS, or other default relating to such information, whether on the client's part or that of the other information sources, unless such fraud, misrepresentation, withholding or such other default is evident to RPS without further enquiry. It is expressly stated that no independent verification of any documents or information supplied by the client or others on behalf of the client has been made. The report shall be used for general information only.

Prepared by:

RPS
101 Park Drive,
Milton Park, Abingdon,
Oxfordshire, OX14 4RY
United Kingdom

Prepared for:

Photovolt Development Partners GmbH,
on behalf of SolarFive Ltd.

Contents

9	OUTLINE SOIL MANAGEMENT PLAN	4
9.1	Introduction.....	4
9.2	Implementation.....	5
9.3	Management and Supervision of the Soil Handling Process.....	6
9.4	Baseline Soils and Agricultural Land Classification (ALC).....	6
9.5	Soil Types and Soil Resources	8
9.6	Development of Soil Restoration Specifications	8
9.7	Key Principles for Soil Management	9
9.8	Monitoring during soil handling and management.	11
9.9	Soil Management Measures for elements of the Project	13
9.10	Aftercare	15
9.11	Monitoring.....	16
9.12	References	16

Appendices

	Appendix A Institute of Quarrying Good Practice Guide	17
--	---	----

Glossary

Term	Meaning
The Applicant	SolarFive Ltd
The Project	The Botley West Solar Farm (Botley West) Project

Abbreviations

Abbreviation	Meaning
ALC	Agricultural Land Classification
DCO	Development Consent Order
CoCP	Code of Construction Practice
Defra	Department for Environment, Food and Rural Affairs
EIA	Environmental Impact Assessment
IQ	Institute of Quarrying
OSMP	Outline Soil Management Plan
PV	Photovoltaic
PVDP	Photovolt Development Partners GmbH

Units

Unit	Description
%	Percentage
ha	hectare
Cm	centimetre

9 Outline Soil Management Plan

9.1 Introduction

Overview

- 9.1.1 This Outline Soil Management Plan (OSMP) has been prepared by RPS on behalf of Photovolt Development Partners GmbH. (PVDP) for the Applicant, SolarFive Ltd. (SolarFive). SolarFive is a licence holder under the Electricity Act 1989. SolarFive is also a company registered in England and Wales (company no. 12602740).
- 9.1.2 PVDP intends to submit an application on behalf of SolarFive for development consent to the Planning Inspectorate (PINS) under the Planning Act 2008. The proposal is to install and operate approximately 840 megawatt electrical (MWe) of solar generation in parts of West Oxfordshire, Cherwell and Vale of White Horse Districts (the Project).
- 9.1.3 This purpose of this OSMP is to describe the methodology and control measures to be adopted during the construction works associated with the Project.
- 9.1.4 A detailed soil management plan (s) would be developed in general accordance with the principles in this outline plan prior to the commencement of construction and prior to decommissioning.
- 9.1.5 The development of this Outline Soil Management Plan (SMP) is based on recognised best practice guidance provided in the Defra Code for the Sustainable Use of Soils on Construction Sites 2009 and Institute of Quarrying Good Practice Guide for Handling Soils in Mineral Workings 2021 (Appendix 1).
- 9.1.6 It is noted that although the IQ guide is titled for use in mineral workings, it is applicable to all infrastructure projects such as there where soils are subject to construction disturbance and volumes of soil are to be stripped, stored, and reinstated. The IQ guide replaced the MAFF Soil Handling Guides (2000).
- 9.1.7 This OSMP has also been informed by:
- Chapter 17 of the ES: Agricultural Land Use and Recreation; and
 - Appendix 17.1 of the ES: Agricultural Land Classification and Soil Resource Survey.
- 9.1.8 The procedures set out in this documentation have been developed to ensure, wherever practicable:
- The conservation of soil resources;
 - The avoidance of damage to soil structures;
 - The maintenance of soil drainage; and
 - The reinstatement of the soil profile as far as possible to its pre-working characteristics.
- 9.1.9 The plan includes the following sections:

- 9.1.10 Proposals for the management and supervision of the soil handling process
- 9.1.11 A summary of the relevant published background and site survey information relevant to the identification of available soil resources within the Site
- 9.1.12 An outline of the soil types and soil resources identified
- 9.1.13 Key Principles for soil management which include measures for soils stripping; soil storage; soil replacement; methods for monitoring suitability of soil handling conditions; methods for the treatment of potential compaction.
- 9.1.14 An outline of the soil management measures for the following elements of the Project:
 - Temporary compound areas;
 - Temporary access tracks;
 - The solar array; and
 - Trenching and cable laying.
- 9.1.15 The aftercare measures to be implemented within the areas of land to be used for conservation grazing.

9.2 Implementation

- 9.2.1 This Outline Soil Management Plan forms an appendix to the Outline Code of Construction Practice (oCoCP). Following the granting of consent for Botley West Solar Farm, detailed Soil Management Plan (s) will be prepared as part of the detailed Code of Construction Practice on behalf of the Applicant.
- 9.2.2 The Applicant has committed to the implementation of detailed Soil Management Plan (s) in accordance with Requirement 11 of the draft Development Consent Order that states:

11.—(1) No part of the authorised development may commence until a code of construction practice for that part has been submitted to and approved by the relevant planning authority.

(2) The code of construction practice must include the following plans;

 - (a) construction traffic management plan;*
 - (b) public rights of way management strategy;*
 - (c) soil management plan;*
 - (d) site resources and waste management plan;*
 - (e) dust management plan;*

(3) The code of construction practice and any plans to be included within the code of construction practice pursuant to sub-paragraph (2) must be substantially in accordance with the outline code of construction practice.

(4) The code of construction practice must be implemented as approved.

9.2.3 The potential delineation of the coverage of the detailed Soil Management Plan (s) for individual works areas will be agreed with the relevant local authority prior to their preparation and the detailed Soil Management Plan (s) will require approval by the relevant planning authority following consultation with relevant stakeholders.

9.3 Management and Supervision of the Soil Handling Process

Site Supervisor

9.3.1 The Contractor would ensure that there would be a designated person responsible (Site Supervisor) for supervising and monitoring the implementation of the procedures set out below.

9.3.2 They will have access to advice during the construction of the Project from a suitably qualified soil handling supervisor, i.e. a suitably qualified and experienced soil scientist or practitioner (an individual with the necessary “Foundation Skills”, having achieved the soil professional competence standards set out by the British Society of Soil Science).

9.3.3 The key responsibilities of the Site Supervisor with respect to the Soil Management Plan would be:

- Ensuring all procedures included in the Soil Management Plan are adhered to during pre-commencement, construction and restoration (or reinstatement) activities;
- Ensuring all contractors/subcontractors are suitably qualified and briefed to implement the measures set out in the Soil Management Plan; and
- Establish a process for the regular review and recording of the quality of the works undertaken in accordance with the Soil Management Plan.

Agricultural Liaison Officer

9.3.4 The Agricultural Liaison Officer (ALO) will be appointed in time for commencement of pre-construction activities and will be the dedicated point of contact for ongoing engagement about practical matters with landowners, occupiers and their agents during the pre-construction and construction phases.

9.3.5 The scope of the responsibilities for the ALO will include undertaking site inspections during construction to monitor working practices including supervising and monitoring the implementation of soil handling methodologies as per the Outline Soil Management Plan.

9.4 Baseline Soils and Agricultural Land Classification (ALC)

9.4.1 The distribution of the soil types and ALC grades have been surveyed and mapped within the site and the results are provided at Appendix 17.1 of the Environmental Statement.

9.4.2 As identified within this Annex the published Soil Survey of England and Wales soil association mapping at a scale of 1:250,000 shows that the site comprises the following soil associations:

- Elmton 1 association (343a) across much of the north of the site, characterised by shallow, well drained, brashy, calcareous fine loamy soils over limestone;
- Aberford association (511a) across the remainder of the north which includes soils similar to the Elmton 1 association but is only locally brashy;
- Denchworth association (712b) across most of the central area between Yarnton and Cassington, and in the south at Farmoor, characterised by seasonally waterlogged, clayey soils;
- Essendon association (714d) around Bladon Heath, comprising seasonally waterlogged, coarse loamy over clayey soils;
- Badsey 1 association (511h) west of Cassington and west of Lower Road, characterised by well drained, calcareous and non-calcareous, fine loamy soils over limestone gravel; and
- Fladbury 1 association (813b) in the valley of the River Evenlode, comprising stoneless, clayey soils variably affected by groundwater

9.4.3 The ALC survey work undertaken has identified the following distribution of ALC grades of the land within the site has been surveyed:

ALC Grade	Area	%
1	2.0	0.15
2	96.00	7.3
3a	407.00	30.9
3b	810	61.5
Non – Agricultural	2.0	0.15
TOTAL	1317.00	100.00

9.4.4 A total of approximately 67ha of land which is included in potential cable options that has yet to be surveyed. Further detailed survey work will be undertaken within this land and used to characterise the soil properties and identify the depths of different topsoil and subsoil units (if necessary) to be stripped within the working areas, to ensure soil types are separately stored and to inform the detailed Soil Management Plan(s).

9.4.5 The following soils information will be collated together with the specification for soil resources (to be stripped and stored in works areas).

- Soil horizon depths, textures and colour for topsoil and subsoil horizons.
- Stone contents, to be estimated from augering and confirmed via soil pit excavation and/or sample analysis.
- Presence and characteristics of mottling, a soil wetness indicator.

- Presence of manganese concretions, a soil wetness indicator.
- Identification of gleyed horizons.
- Identification of slowly permeable layers.
- Identification of impenetrable rock layers.

9.4.6 Soils will be described according to the methods and terminology contained in the Soil Survey Field Handbook (JM Hodgson, 1974).

9.5 Soil Types and Soil Resources

9.5.1 Appendix 17.1 to the environmental statement provides the detailed soil profile data that has been collected across the Site.

9.5.2 This survey work has identified that the following four main soil types are present within the survey area and the location of these soil types are shown on Soil Type figures of Appendix 17.1:

- Imperfectly to poorly draining clayey soils (WC III – IV). Some limestone at depth;
- Well drained to moderately drained clayey or loamy soils (WC 1-II). Some limestone at depth;
- Shallow stones over limestone (within 60cm of ground level)
- Shallow soils over calcareous gravel (within 60cm of ground level)

9.6 Development of Soil Restoration Specifications

9.6.1 The development of the detailed Soil Management Plan(s) for identified work(s) areas would include soil restoration specifications that are based on the distribution of the soil types across the Site and the distribution of ALC grades within soil types, including areas of best and most versatile land. For the limited areas on the Site where soil resources would require stripping, storage and reinstatement, the following information would be included:

- A plan showing the locations of where topsoils or topsoils and subsoils would be stripped, including for access roads; construction compounds; substations; trenching and cable routes.
- A specification for the thickness of topsoils and subsoils to be stripped within different soil types and ALC grade areas, including areas of best and most versatile land;
- The volumes of different topsoil and subsoils resources to be stripped, stored and reinstated.
- A plan showing the location of proposed storage bunds within the area and any associated haul routes
- The specification for the thickness of topsoils and subsoils to be reinstated within different soil types and ALC grade areas, including areas of the best and most versatile land.

9.7 Key Principles for Soil Management

Soil Stripping

- 9.7.1 Soil stripping operations would be carried out by the appointed contractor in accordance with recognised best practice methods in the IoQ guidance 2021. These are likely to be one of the following:
- Sheet A – Soil stripping with excavators and dump trucks
 - Sheet E – Soil stripping with excavators and dump trucks – Windrow practice; or
 - Sheet I – Soil Stripping with bulldozers and dump trucks – Modified Practice.
- 9.7.2 These Guidance sheets are attached at Annex 1.
- 9.7.3 The appointed supervisor would monitor and ensure the handling method is implemented correctly. Haul routes to and from the stripping zones would be established clearly in advance, to ensure that excessive trafficking of subsoils is reduced, as far as possible.

Soil Storage

- 9.7.4 Soils would be moved directly from the area being stripped to areas that have been identified as storage areas. The soils would be stored as close as possible to the area from which they have been stripped.
- 9.7.5 The locations of storage mounds would be planned within the detailed soil management strategy to ensure that the potential for damage to the soil storage heaps and/or contamination of the heaps with foreign construction materials is limited, as far as possible. All storage bunds intended to remain in situ for more than 3 months or over the winter period would be seeded and managed to control weeds as necessary.
- 9.7.6 Stripped soils would be moved to the storage locations by dump trucks running only on pre-determined marked routes which minimise trafficking over exposed subsoil.
- 9.7.7 For storage mound locations the method of mound construction are likely to be as described either in Sheet B (Building Soil Storage Mounds with excavators and dump trucks) or Sheet G (Building Soil Storage Mounds with bulldozers and dump trucks) of the IoQ Guidance (Annex 1). The storage mounds would not exceed 3m in height for topsoil and 5m for subsoils (not likely to be required as part of the Project) and would be located and constructed so that there would be no loss of soil, as far as possible, into any adjacent hedgerows or ditches.
- 9.7.8 They would be constructed by loose tipping of the delivered soil followed by shaping with an excavator or dozer to form a level surface at the top of the mound and uniform gradients down the side as shown above.
- 9.7.9 Soil would be removed from the storage mounds by the method described in Sheet C Excavation of Soil Storage Mounds with Excavators and Dump Trucks

of the loQ Guide (Annex 1). This is illustrated below for a procedure using front loading excavators.

- 9.7.10 Alternatively, soil removal can also be carried out by an excavator located on the storage mound i.e. a reverse of the mound construction procedure described above.

Soil Placement

- 9.7.11 Soil placement operations would be carried out in accordance with recognised best practice and these are likely to be on one of the following loQ guidance methods:

Sheet D – Soil Replacement with excavators and dump trucks; or;

Sheet H – Soil replacement with bulldozers and dump trucks – windrow practice.

Copies of these loQ sheets are attached at Annex 1.

- 9.7.12 Where necessary, loosening of the subsoil would be undertaken in accordance with Sheet N of the loQ guidance (Soil decompaction by excavator bucket) in advance of topsoil being replaced within an area.

Soil Handling and Consistency Tests

- 9.7.13 The assessment of whether soils are in a suitable condition to be handled will be applied in accordance with Defra 2009 guidance and Supplementary Note 4 - Soil Wetness of the Good Practice Guide for Handling Soils in Mineral Workings (IQ, 2021), where appropriate.

- 9.7.14 The assessment would be based on ground and weather conditions and appropriate soil moisture and consistency tests.

- 9.7.15 The most appropriate methodology for handling and storage of the soils will then be determined and agreed via the final Soil Management Plan based on the plasticity and the moisture content of the soils. The handling conditions would be assessed by the Site Supervisor in consultation with the suitably qualified soil handling supervisor.

Treatment of Compaction

- 9.7.16 Whilst the measures within the OSMP are designed to reduce, as far as possible, the potential for soil damage during construction, there may be some circumstances, where limited areas of the site are subject to compaction in the same way that this can occur during the implementation of farming operations across agricultural land, particularly along tramlines, headlands or in gateways and surrounding areas.

- 9.7.17 If areas of limited compaction occur during the construction of the solar array, it would be rectified through the use of appropriate methods. The loQ guides Sheet N and O provide methods using an excavator bucket and bulldozer drawn tines. Copies of these Sheets are attached at Annex 1.

- 9.7.18 Whilst these methods could be applied, it is more likely that standard agricultural cultivation would be applied on the land to rectify any small areas

of compaction. Typical equipment might include the use of a harrow plus roller, or potentially a subsoiler.

Unexpected Contamination

9.7.19 Areas of unexpected contamination may be encountered during construction. The Contaminated Land and Groundwater Discovery Strategy which forms part of the CoCP will be implemented throughout construction.

9.8 Monitoring during soil handling and management.

9.8.1 As identified in Section 9.2 of this plan, the Site Supervisor will be present on site at all times during soil handling who can ensure on-site compliance with the detailed SMPs.

9.8.2 The Site Supervisor will be responsible for undertaking site inspections during soil stripping, storage and replacement operations to confirm that soil handling and management is being undertaken in accordance with this SMP. Soil stockpiles will also be monitored on a monthly basis during the period of storage to check for potential trafficking or contamination.

9.8.3 An example of an on-site inspection checklist to be applied is provided below and would be completed during site inspections, with the inspection details therein to be completed. The results of these inspections will be available on site for inspection and will be made available to the nominated Soil Handling Supervisor to ensure that the soil handling is being undertaken in accordance with the SMP(s) and identify any site actions required.

No	Inspection detail	Y/N	Comments
1	Is someone in a supervisory role present on site who is competent to ensure on-site compliance with the SMP?		
2	Are site personnel adequately aware of how to handle soils appropriately (e.g. evidence of toolbox talks)?		
3	Is appropriate plant/machinery being used for soil handling?		
4	Is traffic across the Site using identified routes? Is there any evidence of trafficking in areas not identified in the SMP?		

No	Inspection detail	Y/N	Comments
5	Are records of soil moisture tests available and do they indicate that the soil has been handled in appropriate conditions?		
6	Are the locations and topsoil and subsoil stockpiles correctly identified with appropriate segregation of different soils?		
7	Are records available of the soil types and volumes of the stockpiles?		
8	Are stockpile heights in accordance with this SMP?		
9	Are stockpiles being maintained and managed appropriately in accordance with the SMP (e.g. appropriate vegetation cover, drainage, fencing and signposting)?		
10	Are there any areas of surface water ponding or signs of soil erosion? If so, have remedial measures been taken and recorded (provide details)?		
11	Are there signs of any unacceptable weed colonisation?		
12	Are the stockpiled soils in a suitable condition for their intended reuse? If not, what remedial measures are required now or prior to reuse?		
13	Are restoration depths for each soil horizon in accordance with the SMP and soil specification?		

No	Inspection detail	Y/N	Comments
14	Has appropriate seeding/planting been successfully undertaken following restoration and have any required maintenance measures been implemented?		

9.9 Soil Management Measures for Elements of the Project

9.9.1 Section 6 sets out the soil management measures for the following elements of the Project:

- Temporary compound areas;
- Temporary access tracks;
- The solar array;
- Trenching and cable laying; and
- Site fencing arrangements.

Temporary Compounds

9.9.2 Topsoils would be stripped and moved directly from the area being stripped to areas that have been identified as topsoil and subsoil storage which would be located around the perimeter of the compound areas. All storage bunds would be seeded and kept weed free. Topsoil storage mounds would not exceed 3 m in height.

9.9.3 Aggregate to create hard standing surfaces would be laid over the subsoil with a separating geotextile membrane. Drains would be laid below the track and hard standing where appropriate.

9.9.4 Upon completion of the works, the aggregate material, geotextile membrane will be removed off site.

9.9.5 The method of mound construction and excavation would be in accordance with the Construction Code of Practice (Defra, 2009) and the relevant methodology from the in Mineral Workings (IQ, 2021).

Temporary Access Tracks

9.9.6 If alignments of the tracks need to be stripped, topsoils would be stripped along the alignment of the temporary access tracks and placed directly adjacent to the access as far as possible. If soils are required to be stored outside areas of high flood risk, these would be stored in bunds that would not exceed 3m in height in areas suitably located to ensure no damage to the storage heaps and/or contamination with foreign construction materials, as far as possible.

9.9.7 Upon completion of the works, topsoils would be reinstated along the routes of temporary tracks in accordance with the Construction Code of Practice (Defra, 2009) and the relevant methodology from the in Mineral Workings (IQ, 2021).

9.9.8 In the event that soils do become subject to compaction when the temporary tracks are removed, these areas would be subject to amelioration either using the methods outlined in the IoQ guides (2021) prior to the replacement of the topsoil.

Solar Array

9.9.9 The process would involve the following stages which would include:

- The marking and laying out of the framework for the array;
- the placement of the legs on site which are then driven into the ground using an impact piling or screwing rig to a depth of approximately between 1 – 3.0m.
- The framework for the PV panels is then bolted together; and
- The PV panels are installed.

9.9.10 There is no soil stripping proposed in relation to the installation of the framework and the panels.

9.9.11 Installation of panels would take place, as far as possible, when soil conditions are suitable as determined through soil handling and consistency tests (paragraphs 9.5.13 to 9.5.15 above).

9.9.12 However, in the event that soils do become subject to rutting due to vehicle trafficking in areas of the solar array construction, these would be subject to amelioration either using the methods outlined in the IoQ guides (2021) or standard agricultural cultivation equipment such as tine harrows.

Trenching and Cable Laying

9.9.13 Cable laying, by a trenching machine or excavator, will excavate trenches to a maximum depth of 1.2m. The type of machinery that would be used is illustrated in the BRE National Solar Centre “Agricultural Good Practice for Solar Farms” (2013) is illustrated below:



9.9.14 Topsoils would be stripped and stored adjacent to one side of the trench. Similarly, subsoils would be stripped and stored separately on the opposite side of the trench.

9.9.15 Following installation of cabling, stored soils would be replaced within the trench in sequence, with subsoils replaced first before topsoils are replaced. In the event that soils do become subject to compaction during the installation of cabling, these would be subject to amelioration either using the methods outlined in the IoQ guides (2021).

9.10 Aftercare

9.10.1 The distribution of proposed land use during the operation of the Project, following the construction period, is provided in the Outline Landscape and Ecological Management Plan (reference).

9.10.2 In establishing the areas of grassland for conservation grazing, prior to seeding operations the following management measures would be determined:

- Cultivations to be undertaken, which would depend on the soil type and site conditions, but could include the use of a plough, harrow and roller;
- Seed mixture to be used for initial grass establishment; and
- Soil samples would be taken from the area of any banded soils to be used in the restoration of the area to determine nutrient levels and inform proposals for any lime and fertiliser applications.

9.10.3 At the end of the first year following cultivations and seeding operations, there would be an onsite review (with interested parties), which would comprise the following:

- A review of the physical soil characteristics of the restored land which would include examination of soil auger borings within each soil type affected in each works area;
- Identification of requirements for further cultivation activities;
- Identification of requirements for further remedial measures;
- Collection of samples to check soil nutrient levels and inform lime and fertiliser requirements.

9.10.4 The onsite review would enable the management requirements to be identified for the following year.

9.11 Monitoring

9.11.1 The Outline Landscape and Ecological Management Plan (oLEMP) monitoring of newly created habitats would be undertaken in Years 1, 2, 4, 6 and 10, followed by once every 5 years for the lifetime of the Project. Monitoring of restored soils will be undertaken at the same intervals.

9.11.2 The data obtained from these monitoring events will be used to compare against the initial 'baseline' data obtained on completion of the construction phase of the Proposed Development and inform any updates to the LEMP.

9.11.3 During each monitoring event across the works areas, it is proposed to carry out the following.

- Examination of the soil profiles within each soil type affected in each works area to undertake an assessment of the soil structure and development of the profile.
- Obtain soil samples from each soil type affected in each works area for soil nutrient screening.
- Provide a summary report comparing the current monitoring event against all historic monitoring and interpretation of the available data and identifying any changes and improvements noted.

9.12 References

Defra (2009) Construction Code of Practice for the Sustainable Use of Soils on Construction Sites

IQ (2021) Good Practice Guide for Handling Soils in Mineral Workings

BRE National Solar Centre (2014) Agricultural Good Practice Guidance for Solar Farms

Appendix A

Institute of Quarrying Good Practice Guide

IQ

The Institute
of Quarrying



Good Practice Guide for Handling Soils in Mineral Workings

GOOD PRACTICE GUIDE FOR HANDLING SOILS

In Mineral Workings

Published in the UK by:

The Institute of Quarrying

McPherson House
8a Regan Way
Chetwynd Business Park
Chilwell,
Nottingham
NG9 6RZ

www.quarrying.org

© 2021 The Institute of Quarrying

All rights reserved. No portion of this publication may be reproduced, stored in a retrieval system or transmitted at any time or by any means mechanical, electronic, photocopying, recording or otherwise without prior, written permission of the publisher.

The information in this publication is general guidance on the best practices and approaches to soils guidance. Specialist advice should always be sought if you need more details about what action to take in your own circumstances.

First Edition published 2021.

For over 100 years the Institute of Quarrying has been supporting people working in the mineral extraction industry. It is the only international professional body for quarrying, construction materials and the related extractive and processing industries. IQ's focus is to be the global leader in standards for the sector, to push innovation and operational best practice, to support the industry in driving healthy, sustainable workplaces and to promote the positive impact of the industry and profession. Being a member of IQ means being part of a global community of industry professionals committed to sharing knowledge and improving industry standards.

GOOD PRACTICE GUIDE FOR HANDLING SOILS

In Mineral Workings

PART ONE: Introduction

Contents

Part One

Introduction

05	Foreword
06	Acknowledgements
07	Preface
09	Introduction
10	Key Issues
15	Choosing Machinery Combinations, Handling & Remedial Practices
26	Supplementary Note 1 – Soils
30	Supplementary Note 2 – Soil Resource & Management Plan
31	Supplementary Note 3 – Compaction
35	Supplementary Note 4 – Soil Wetness
38	Supplementary Note 5 – Soil Mixing
39	Glossary of Terms

Contents

Part Two

Model Methodologies

40	<u>SHEET A</u> Soil stripping with excavators and dump trucks – Sequential bed/strip practice
48	<u>SHEET B</u> Building soil storage mounds with excavators and dump trucks
54	<u>SHEET C</u> Excavation of soil storage mounds with excavators and dump trucks
59	<u>SHEET D</u> Soil replacement with excavators and dump trucks – Sequential bed/strip practice
71	<u>SHEET E</u> Soil stripping with excavators and dump trucks – Windrow practice
80	<u>SHEET F</u> Soil stripping with bulldozers and dump trucks – Windrow practice
88	<u>SHEET G</u> Building soil storage mounds with bulldozers and dump trucks
94	<u>SHEET H</u> Soil replacement with bulldozers and dump trucks – Windrow practice
104	<u>SHEET I</u> Soil stripping with bulldozers and dump trucks – Modified layer by layer practice
111	<u>SHEET J</u> Soil replacement with bulldozers and dump trucks – Modified layer by layer practice
121	<u>SHEET K</u> Hybrid soil replacement with excavators, bulldozers and dump trucks – Modified layer by layer practice
132	<u>SHEET L</u> Release and removal of stones and non-soil debris by excavator and stoke-rake
138	<u>SHEET M</u> Release and removal of stones and non-soil debris by bulldozer drawn tines
144	<u>SHEET N</u> Soil decompaction by excavator bucket
150	<u>SHEET O</u> Soil decompaction by bulldozer drawn tines

Foreword

Over the past twenty years the MAFF guidance has been widely used by the mineral industry and planning authorities, and their advisors. With the recent changes in land use (natural capital) and environmental (climate and biodiversity) related policies it is appropriate that the guidance is updated and expanded to include these.

In recognition of this, the Institute of Quarrying undertook to update the guidance in consultation with Natural England and the Welsh Government. This was with the support and guidance of a Steering Group representing the minerals industry, mineral planning authorities, and professional bodies and specialist consultants.

Attention is rightly focused on soil natural capital to ensure that the natural resource is left in a measurably better state than beforehand. Environmentally positive policies are increasingly driving operational practices, and as the professional membership body for the quarrying and aggregates sector, the Institute believes it is critical to provide current guidance that supports better performance outcomes for the industry. The Institute of Quarrying is proud to have worked with all of the stakeholders on the project to revise and update this guidance and also thank you to all those who have contributed.

James Thorne
Chief Executive
The Institute of Quarrying
July 2021

Acknowledgements

Author

Dr R N Humphries CBiol CSci FRSB FBSSS FIQ
Blakemere Consultants Ltd & Celtic Energy Ltd

Steering Group

R J Smallshaw	Steering Group Chair and Institute of Quarrying
J Holloway	Natural England
A W Williams	Welsh Government
B Pilgrim	Banks Mining
M Young	Breedon Group
G Watkins	Hanson UK
L Gilbert	HS2 Ltd
D Park	Tarmac a CRH Company
A Hawkes	Chepstow Plant
M Tweddle	Durham County Council
S Elson	Surrey County Council
S Warren	British Aggregates Association
B Lascelles	British Soil Science Society
I Briggs	Landesign Planning and Landscape Ltd
I Meadows	Meadows Archaeology

Dr S G McRae (Consultant), Dr N A D Bending (Progressive Restoration), R Stock (Consultant), V Redfern (Consultant) and R J K Thompson (Celtic Energy Ltd) kindly provided further comments and insights.

The supporting art work was provided by R Shelton (H J Banks & Co) and D Fisher (Blue Room Graphics Ltd).

Preface

In 2000 MAFF published its Good Practice Guide for Handling Soils by a range of earth-moving machines. This was a comprehensive guide to soil handling practices to help achieve a high standard of reclamation for mineral extraction sites across all agricultural land qualities (DoE 1989; DETR 1999; Welsh Assembly Government 2004 & 2009; Welsh Government 2021). It also contributed to the drive to achieve a more sustainable use of soils (DEFRA 2009a & 2009b).

The focus of current UK Government policy in England, as set out in its 25 Year Environmental Plan (DEFRA, 2018), is to safeguard soil resources (as Natural Capital, DEFRA, 2021) and that by 2030 for all soils to be managed sustainably. The same objective of Sustainable Management of Natural Resources (SMNR) is encompassed in the Environment (Wales) Act (National Assembly of Wales, 2016). Good quality agricultural soils are to be protected and all soils are to be fully valued for their environmental and ecosystem services and are to be better managed to improve soil health. The purpose of this updated guidance is to assist the mineral industry in their contribution by achieving sustainable soil based after uses and that impacts on the soil resources and soil functions are minimised and enhanced wherever possible.

The purpose of **Part One** of the Institute of Quarrying's updated guidance on good soil handling practice by machines is to provide an overarching explanation of the context and aims of the model methods given in Part Two.

In addressing the new Natural Capital driven policies for protection of soil resources and their sustainable management, soil compaction and its associated limitations on soil functions has long been known to be the main adverse effect of handling and trafficking soils with earth-moving machines.

It remains the primary challenge for successfully achieving the intended after uses and the maintenance provision of defined environment

and ecosystem services, and the associated soil functions associated with healthy soils. Whilst the occurrence and degree of compaction is related to the choice of machinery combination and handling practice, they are also a function of the type of soil and wetness of the soils at the time of handling.

The prime aim of the guidance is to minimise the compaction of soils as they are handled with the minimal reliance on the need for remedial treatment of compaction caused by the machinery and handling practices. Hence, in the updated guidance greater attention is given to the wetness of soils during handling operations.

It also introduces the key role of the Soil Resource & Management Plan. This should be the primary reference material for characterising the soil resources available, informing and successfully delivering the intended after use(s) whether it is agricultural, horticultural, forestry, semi-natural vegetation/ecosystems or other soil-based ones. It will underpin the operational design, land use and landscaping plan, and the practices needed to be deployed, and the means of communication to all those involved. The importance of competency in the technical understanding of soils and the implications of the operational practices is also emphasised.

The familiar MAFF presentation of the model methods as individual 'Sheets' has been retained in Part Two for everyday communication to all levels of users. Model methods are provided for the two widely used machinery combinations of excavators & dump trucks, and bulldozer & dump trucks. The MAFF model methods for the use of earth-scrapers are no longer included but can be found in the National Archive (DEFRA, 2009c, Sheets 5 to 8).

Model methods are provided for the three most commonly used soil handling practices (the 'bed/strip', the 'windrow/peninsular' and the layer by layer).

A method for an alternative 'loose-tipping' approach (using excavators for the subsoil and bulldozer for the topsoil) is a new addition.

The processes of decompaction and the removal of stones/non-soil debris in the soil replacement procedures are now integrated into the method sheets.

It is intended that this guidance remains as a 'live' document and is updated with site experiences and future developments in mineral extraction.

References

[Department of the Environment, 1989. Minerals Planning Guidance 7: Restoration of Mineral Workings \(paragraph 2\)](#)

Department of the Environment Transport & the Regions, 1999. A better quality of life: a strategy for sustainable development for the United Kingdom (paragraphs 6.66 and 8.50). Stationery Office, London

[Department of Environment, Food & Rural Affairs, 2009a. Safeguarding Our Soils: A strategy for England](#)

[Department of Environment, Food & Rural Affairs, 2009b. Construction Code of Practice for the Sustainable Use of Soils on Construction Sites](#)

[Department of Environment, Food & Rural Affairs, 2009c. Good practice guide for handling soils](#)

[Department of Environment, Food & Rural Affairs, 2018. A Green Future: Our 25 Year Environment Plan to Improve the Environment](#)

[Defra, 2021. Enabling a Natural Capital Approach: Guidance - GOV.UK \(www.gov.uk\)](#)

[National Assembly of Wales, 2016. Environment \(Wales\) Act](#)

[Welsh Assembly Government, 2004. Minerals technical advice note \(MTAN\) Wales 1: aggregates](#)

[Welsh Assembly Government, 2009. Minerals technical advice note \(MTAN\) Wales 2: coal](#)

[Welsh Government, 2021. Planning Policy Wales - Edition 11](#)

Introduction

Minerals are recognised as essential Natural Capital, providing for our modern society and its wellbeing, as are the soil that covers the mineral resource (Wikipedia, 2020).

Soils provide essential environmental and ecosystem services, such as food, water regulation including water infiltration and flood avoidance, carbon storage, and biological functioning. Consequently, current planning and environmental policy not only protects good quality agricultural soils but also focuses on the sustainable management of all soil resources and to ensure their ecosystem services are fully valued and their use is sustainable. Hence, the machines and handling practices used in the recovery and conservation of soil resources (Humphries et al, 2018), and their reuse in the reclamation of mineral extraction sites will be material considerations in the granting of planning consent.

The updated guidance is intended for use by planning officials, statutory consultees, mineral operators and their supporting teams and specialist consultants, and earth-moving contractors, their site supervisors and machine operators. It has key

roles to play from i) the inception of projects and their development through to the application and securing of planning consent, and to operational implementation, to ii) providing the basis for training modules. Its adoption throughout all these stages processes should ensure that the necessary actions are addressed and communicated to all those involved (**Figure 1**) and that they are fully informed as appropriate so that the best results possible are achieved.

In **Part One** the important aspects of soil handling are introduced under the headings of Key Issues and Choice of Machinery Combinations, Handling & Remedial Practices, and these are supported by Supplementary Notes.

KEY ISSUES

- Health & Safety
- Soil Natural Capital, Soil Function & Ecosystem Services
- Soil Resource & Management Plan
- Soil Compaction
- Soil Wetness
- Monitoring & Recording
- Planning Conditions & Control

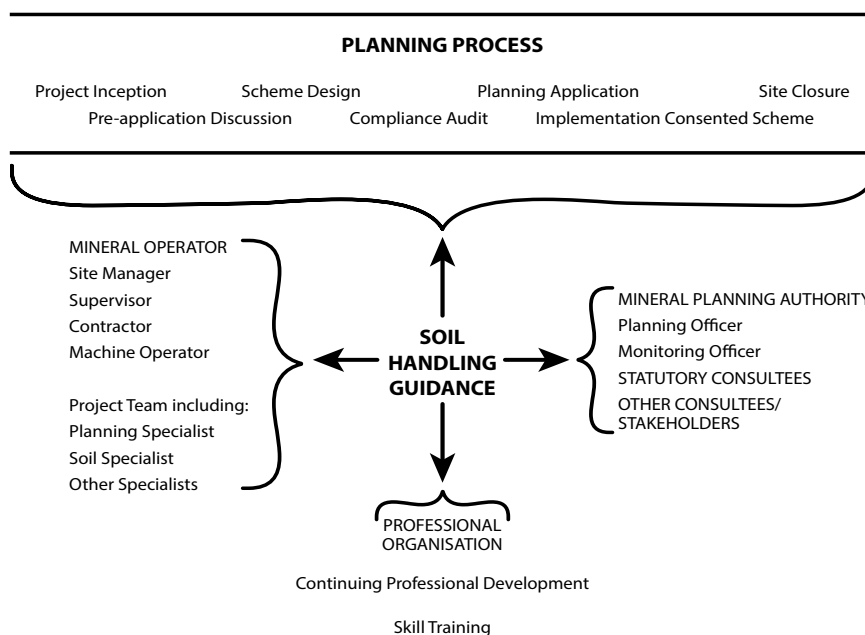

Figure 1: Key informative and training role of the soil handling guidance in the development and reclamation of mineral workings.

Choosing Machinery Combinations, Handling & Remedial Practices

- Health & Safety
- Available Machinery Combinations
- Commonly Deployed Soil Handling Practices
- Available Remedial Practices
- Relative Risk of Significant Compaction: Machinery combinations & Handling Practice / Soil Storage / Efficacy of Soil Recovery / Relative Susceptibility to Rainfall Delays
- The Deployment of Earth-moving Machinery & Handling Practices
- Remedial Treatment of Compaction
- Removal of Stones and Non-soil Debris
- Cultivations Following Soil Replacement
- Under-Drainage
- Vegetation Cover

Supplementary Notes

- 1. Soils
- 2. Soil Resource & Management Plan
- 3. Soil Compaction
- 4. Soil Wetness
- 5. Soil Mixing

Part Two provides detailed model methods of best practice for each machinery combination and soil handling practice. However, in doing so the guidance does not specify size, make or model of equipment as this is left to the mineral operator and/or contractor to specify, justify and provide.

KEY ISSUES

Health & Safety

Of overriding importance is the issue of safety. All persons involved in the handling of soils must comply with all relevant legislation with respect to Health and Safety, in particular the Health and Safety at work Act 1974 (UK Government, 2020a) and in the case of mineral extraction operations The Quarries Regulations 1999 (UK Government, 2020b) and its relevant statutory provisions, especially those aspects which relate to the construction and removal of tips, mounds and similar structures.

The users of this guidance are solely responsible for ensuring all activities comply with safety legislation

and good practice, including the manufacturer's specifications for the safe operation of the specific machines being used, and that all machines are in a good condition and well maintained. The machines must be of a kind which are appropriate for the task and the outcomes required and can carry out the work safely and efficiently. These requirements take preference over any suggested practice in this guidance. For example, the position and orientation of an excavator on handling soils which could affect its stability, and the positioning and proximity of other machines as described in the text and shown in the illustrations.

It is important that those involved in the operation of earth moving machines are competent and have the necessary training and certification.

Soil Natural Capital, Soil Function & Ecosystem Services

The concept of Natural Capital, from which we as human society derive the benefits of supporting, provisioning, regulating and cultural environmental/ecosystem services, will become firmly established in future land use policy and decision making by central and local government (UK Government, 2020c).

Natural Capital includes soil, minerals, water, and other natural resources. Soil based ecosystem services provide food and fibre, regulate water quality and drainage, store carbon and help regulate greenhouse gases, support biodiversity and biological functioning of soil, and is the basis of our modern-day culture. Hence, the services they provide are an important consideration in the exploitation and reclamation of mineral sites.

Soils with different textures and structure differ in their land use capability and level of environmental and ecosystem services provided. The composition and condition (or health) of soils, and their functioning, can be significantly altered during soil handling. This can have consequences for the subsequent delivery of environmental/ecosystem services and the after use of land and can be costly to remedy. Losses and degradation of soil natural capital and its services can be a consequence of the soil machinery and handling practices used.

Hence, the characterisation of the affected soils (see Supplementary Note 1) will be an important factor in determining the choice of machinery combination and handling practice.

Soil Resource & Management Plan

A Soil Resource & Management Plan (SRMP) (see Supplementary Note 2) is an essential component and integral part of the updated guidance. It has a key role in achieving the successful delivery of the intended after use, and the conservation and functioning of soil resources in mineral extraction schemes. It should be the prime source of soil resource and handling information (British Society of Soil Science, 2021; Natural England, 2021), and used as the means of communication to all those involved in the design and specification, decision making, and oversight and audit of the scheme from a project inception and development through all the stages from the planning application to site closure (Figure 2). It is also a means whereby everyone involved can be updated and liaise regularly to ensure the best results possible are achieved.

The SRMP comprises essentially:

- i) a field survey to characterise in detail the

soil resources on the site and where agricultural land, the associated agricultural land classification grades,

- ii) develops the baseline information into a soil handling and management plan describing in detail how the site is to be developed during mineral extraction, and
- iii) its reclamation (restoration & aftercare).

It should contain location of the mineral, and any other relevant site, operational and infrastructure details (see Supplementary Note 2). Successful soil handling and restoration schemes are dependent on having a detailed soil resource survey (including an ALC where needed) to be undertaken by appropriately qualified and experienced soil specialists (British Society of Soil Science, Undated) which are then interpreted into practical soil advice on scheme design and phasing, identifying any particular constraints and opportunities for future after-uses, proposals for stripping and replacement soil units, along with any particular requirements.

The SRMP must show the soil resources to be recovered or substituted (as soil forming materials, Bending et al, 1999) and their use in the

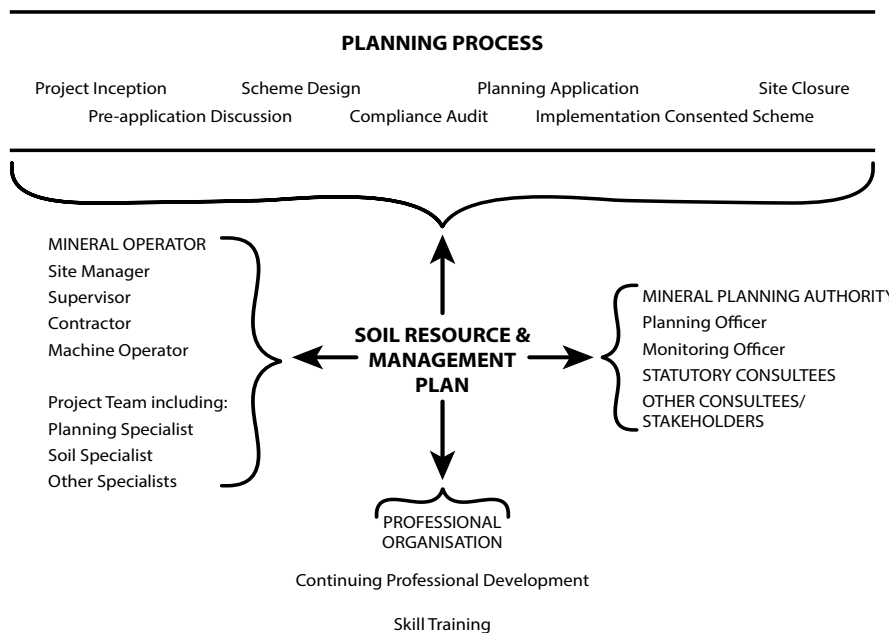

Figure 2: Key informative role of the soil resource & management plan in the development and reclamation of mineral workings

replacement scheme appropriate to the intended after uses and ecosystem services to be provided. In consultation with the mineral operator and planning authority, having taken the safety constraints (such as ground conditions, gradient) into account, the SRMP should state the type of earth-moving machinery, specify the handling, storage and remedial practices to be deployed to achieve the intended after use, and the provisioning of environmental and ecosystem services.

The SRMP should show where the access and haul routes and soil storage areas are to be located and their progressive development throughout the operations.

In most cases the areas for infrastructure, haul routes and those soil storage areas are to be stripped of soils before the rest of site is developed. The SRMP should identify any deviation from good soil handling practices, for example where haul routes may have to be upon the in-situ topsoil because of low load bearing capacity of the lower soil profile or underlying material. This may also be the case where there is known archaeological that need to be protected prior to ground investigations taking place.

The occurrence of other constraints/influences on the selection of machinery and/or handling practice, and the contingencies to be made should be included in the SRMP. For example, the occurrence of buried archaeological artefacts can determine the soil stripping practice (**Table 1**) or the occupation of the affected land by ground nesting birds (UK Government, 2021a) can delay or modify operations too late in the season.

The SRMP should include the rainfall and soil moisture limits the soil handling operations are work to and agreed with the Planning Authority before determination and included in the earth-moving contract.

Importantly, the SRMP should identify the roles and responsibilities of those involved, and the details of monitoring and reporting to take place. The soil handling provisions within the SRMP are to be communicated to all those carrying out the work and in particular the site supervisors and machine operators by appropriate means, including detailed plans, toolbox talks and site demonstrations.

Supervision by trained staff is essential, as is the monitoring and reporting by competent

Machinery Combination & Handling Practice (see Part Two)	Watching brief	Investigation & recording
Excavator – Dump Truck Using Bed/Strip Practice (Sheet A)	Suitable	Not suitable
Excavator – Dump Truck Using Windrow/Peninsular Practice (Sheet E)	Suitable	Suitable
Bulldozer – Dump Truck Using Windrow/Peninsular Practice ¹ (Sheet F)	Not suitable	Not suitable
Bulldozer – Dump Truck Using Modified Layer by Layer Practice (Sheet I)	Not suitable	Not suitable

Table 1: Likely Suitability of Soil Handling Methods for Archaeological Investigations

soil specialists (British Society of Soil Science, Undated).

Soil Compaction

Compaction within the replaced profile is the most common problematic condition of replaced soils (Reeve et al, 2000). It is often overlooked as a factor inhibiting the successful delivery of the intended after uses, function and services, resulting in poorer growth of crops or other vegetation, reduced water infiltration and storage leading to enhanced risk of run-off, erosion and flooding, and reduced soil aeration and normal biological functioning with risk of increased emissions of nitrous oxides (potent greenhouse gases). Whilst the risk of compaction is exacerbated by handling soils when wet (Duncan & Bransden, 1986), it can occur in drier conditions through excessive machinery trafficking. The degree and significance of effect is likely to vary between the types and size of machinery used and the handling practice adopted, soil textural class and soil wetness condition (see Supplementary Note 3).

Whilst some degree of remedial effect can be achieved where appropriate equipment is used and the soil mass is sufficiently dry to enable shattering (Bacon & Humphries, 1987; Dunker et al, 1992; Spoor, 2006), experience has demonstrated that practices which minimise the trafficking of the soil by machinery is the more effective and reliable option (Bransden, 1991; Reeve et al, 2000). However, for some after uses, such as wetland ecosystems where the drainage is to be impeded, some compaction within or below the soil layer may be necessary to create the required wetness condition. For other habitats the deliberate degradation of soil functions (e.g., fertility and drainage) by soil mixing or other means may be necessary to achieve particular habitat creation schemes (see Supplementary Note 5).

Advice is given in **Part Two**, Sheets S & T, on the use of the two remediation options available, and when and how they should be integrated into the soil replacement process, and the monitoring of their efficacy.

Where relevant, these are likely to be specified in

the planning consent and should be stated in the SRMP and agreed with the planning authority.

Soil Wetness

There are two causes of soil wetness;

- i) the inherent water regime of the soil (wetness class) based on the average duration of waterlogging at different depths and determined by reference to soil characteristics and local climate (MAFF, 1988)
- ii) the shorter-term effect of individual rainfall (precipitation) events.

Historically, soil water content and variations in climate across England and Wales has been a significant and sometimes an overlooked factor in determining the delivery of some intended after uses and services, such as productive agriculture and forestry. An increase in soil water content (soil wetness) increases a soil's susceptibility to compression and smearing (compaction) during all handling operations (Duncan & Bransden, 1986). The resulting compaction degrades the soil's ability to recover functionally and hence the delivery of the intended after uses and services (see Supplementary Note 4).

The degree of effect due to soil handling is likely to vary between the soil textural class, structural condition, and organic matter content, the local climate and daily weather conditions, but also between the types and size of machinery used and handling practice adopted. The primary cause of compaction arises from the compression caused by trafficking by the machinery and stockpiling of soil in storage.

Whilst some degree of remedial actions might be possible, experience has demonstrated that minimising compaction by handling soil in a dry condition is the more effective and reliable, and likely most cost-effective option.

Action can be taken to minimise the consequences of soil wetness through the timing of operations to coincide with the drier season (Reeve, 1994), the maintenance of a transpiring vegetation cover and site drainage and allowing exposed soils to dry out

after significant rainfall events (see Supplementary Note 4). Although the practice of windrowing soils is suggested as a mitigation measure (DEFRA, 2009b), it is likely to cause additional damage by the handling and should not be relied upon in mineral extraction schemes.

It is likely that when soils are in a wet condition the issues of unsafe operation and inefficient working will arise. Here, it is a joint operational, environmental and soil protection decision by those responsible for whether handling should start, continue, cease, or restart.

Advice is given in Supplementary Note 4 on the general timing of operations and a field-based determination of when the actual operations should start, cease or restart based upon actual soil wetness. This process should be set out clearly in the SRMP and agreed with the planning authority, along with a mechanism whereby further consultation and amendments can take place as circumstances arise.

Monitoring & Reporting

The requirement for monitoring and reporting during the operational stages of a mineral extraction scheme is an integral part of the soil handling process (Natural England, 2021). The details of which would be agreed with the planning authority and set out in the Soil Resource & Management Plan or if not, it should be required as a planning condition. The monitoring would provide the basis for any actions needed in the subsequent aftercare period. Importantly, the SRMP provides a factual basis for compliance and completion audits by the planning authority Monitoring Officers in their oversight and regulation roles of mineral extraction schemes.

General compliance monitoring recording of the actual practices used is likely to be undertaken by the planning authority, but regular soil audits and assessments for specific soil conditions (soil wetness and compaction) should be by competent soil specialists (British Society of Soil Science, Undated).

Standard methods for soil physical conditions, soil

structure and Soil Wetness Class are described in Hodgson (1997), MAFF (1982) and (MAFF, 1988) respectively. In addition, visual assessment methodologies (Ball & Munkholm, 2015; Ball et al, 2017, SRUC, 2021) for soil structure and function are now widely deployed and often in conjunction with other determinations such as organic matter content and micro-biological activity (Humphries et al, 2019). Without this basic information it will not be certain if the intended soil functioning and ecosystem services have been met by the choice of practice and machinery, and by subsequent aftercare actions.

Planning Conditions & Control

Soil resources and handling practice is likely to become more of a significant planning consideration for all future mineral developments given the recent focus on the sustainable management of soil natural capital (UK Government, 2014; UK Government, 2020c). This would require the provision of all relevant soil information about the development site and its after use before determination can be made by the planning authority, whether or not a scheme falls within the Environmental Impact Regulations.

In the past for those requiring an Environmental Assessment the information was usually provided in the submission even though the same and further information was often required to be resubmitted subsequently by means of a planning condition. The reliance on multiple submissions often resulted in discrepancies between the application and conditioned proposals. It should be made clear at the pre-application scoping/consultation and during the pre-determination stage that an integrated and comprehensive Soil Resource & Management Plan (SRMP) is required to enable planning determination and not a matter of subsequently requiring it as a planning condition, as often has been the case. In doing so, the SRMP should be required by a suitable planning condition to be updated prior to development and thereafter annually throughout site development, its reclamation (restoration and aftercare) (DEFRA, 2005).

If the methodology needs to be modified or changed, for example due to site conditions, this

should be agreed in advance with the mineral planning authority and documented by updating the SRMP.

Given that planning consents are legally enforceable, it is essential that there is an appropriate level of flexibility provision in the SRMP to enable speedy resolution of unexpected and insignificant operational or soil resource issues that arise during active soil movement operations. It would be expected that the SRMP would set out a protocol for the scope and consequences for the planning authority and its advisors to deal with what might be such instances as needing a change in machinery and/or practice. Hence, it is essential that appropriately detailed site studies and assessments are undertaken in the first instance by appropriately qualified and experienced personnel. However, significant changes to a scheme and the SRMP, such as replacing soils that were not capable of supporting agriculture when that was the original scheme, would probably need to be dealt with through a Section 73 planning application (UK Government, 2020d).

CHOOSING MACHINERY COMBINATIONS, HANDLING & REMEDIAL PRACTICES

Health & Safety

The primary decision as to which machinery and practices to be used is a matter of operational safety and those who have this responsibility. Commonly occurring limiting safety factors are gradient, topographical complexity, and ground stability.

Those of the trafficability of haul routes on areas stripped of soil due to surface wetness can be managed by the stoppage of works to allow the drying or the deployment of bulldozers/ graders to remove the slurry or the laying of a suitable surface etc.

Available Machinery Combinations

The most commonly used machine combinations for stripping, storage and replacement operations for mineral extraction schemes in the UK are either, excavators with dump trucks (**Part Two**, Sheets A – D, & E) or bulldozers (with an excavator to load

the dump truck at soil stripping) and dump trucks (Sheets F – H). A hybrid combination of excavator replaced lower soil horizons with bulldozer spread topsoil tipped from dump trucks is sometimes deployed (Sheet K). Other machines such as graders and bulldozers are usually deployed in the maintenance of haul roads (Humphries et al, 2018).

Commonly Deployed Soil Handling Practices

Guidance is given in **Part Two** on the three commonly used handling practices deployed in mineral sites for soil stripping and replacement.

These are:

- i) the 'bed/strip by strip' (Sheets A & D),
- ii) the 'windrow/peninsular' (Sheets E, F & H) and
- iii) the modified 'layer by layer' methods (Sheets I, J & K).

The replacement using the bed/strip system with excavators and dump trucks is often referred to as 'loose soil tipping', but generally are also truck tipped soils graded using bulldozers.

Available Remedial Practices

During the course of soil replacement actions may be needed to treat significant compacted soil layers (**Part Two**, Sheets N & O) and/or to remove stones and debris such as concrete slabs and wire-rope (Sheets L & M).

The commonly used practices are to deploy bulldozer drawn tines or excavators with specialist stone-rake buckets. Their deployment of these is integrated into the updated model method Sheets for soil replacement.

Relative Risk of Significant Compaction

Machinery Combination & Handling Practice

The risks of soil compaction, efficacy of soil resource recovery and replacement, and susceptibility to rainfall interruptions differ between the machinery combinations and handling practices. This should be addressed in the Soil Resource & Management Plan.

The risk of significant compaction and susceptibility of different soil horizons should be a particular

consideration when determining the likelihood of delivery of the intended after use.

The inherent risk is largely a function of the ground pressure of the machinery, amount of trafficking of the soil that takes place, and soil bearing capacity (largely related to soil wetness). The size (ground pressure exerted and its operating footprint) of the machinery is the primary agent in soil compression, but also the mode of operation (number of passes, traction and turning manoeuvres) and the care taken.

Intuitively the smaller variants of the machines exert the less pressure and are usually the better option, but they may result in more trafficking and difficulties in operation than larger units because significantly more passes are needed to achieve the same output, as sometimes can also be the case with wide tracked (low ground pressure) bulldozers.

Soils and their horizons can differ in their susceptibility to compaction depending on their 'textural class' (largely a function of their clay and organic matter contents), degree of structural development, and water retention properties.

Coarse textured mineral soil, such as sands and loamy sands, are significantly less susceptible than the finer clayey and silty soils. Peaty (>20% organic matter) and organic (8-20% organic matter) soils generally have an inherent low resilience to compaction (Askew, 2020). However, risk levels are also significantly modified by the soil water regime (Soil Wetness Class) and the local climate.

Table 2 sets out the relative inherent risk of damage to soils (when in dry/non-plastic condition) during soil handling. However, the depth to a duration of saturated soil and climate (Soil Wetness Class & Field Capacity Days, MAFF, 1988) are confounding factors where, for example, sandy soils can be at high risk where soils remain saturated at a shallow profile depth (Askew, 2020).

Soils with weakly developed structure (aggregation of particles) may be more susceptible than those which have strong more stable aggregates, and mineral soils with a high organic matter or calcium carbonate content can be more resistant to compaction, with topsoil tending to be more resilient than subsoil.

Risk to Soil Structural Damage During Handling When in a Dry Condition	Soil Texture Class (top- & subsoil)
High Resilience - Low Risk	Sand, loamy sand, sandy loam, sandy silt loam
Medium Resilience Moderate Risk (<27% clay content)	Medium silty clay loam, medium clay loam, sandy clay loam
Low Resilience High Risk (>27% clay content)	Silt loam, heavy silty clay loam, heavy clay loam, sandy clay, silty clay, clay; organic mineral, peaty soils, peat

* Based on Askew, 2020

Table 2: Simplified Inherent Risk of Soil Structural Damage Occurring within the Soil Profile Based on Soil Texture*

However, clayey soils with an apedal structure and low porosity may be less significantly affected by further compression.

Soil wetness is a major determinant of the susceptibility to compaction when trafficked by machines (Duncan & Bransden, 1986) (also see Supplementary Note 3). The differential degree of compaction between machinery combinations and handling practices is less when the soils are in dry condition. Dry soil is more resistant to compression than wet soils which have a water content at or above their plastic limit when fine (clay and silt fraction) soil particles become ‘mobile’ within compression increasing their packing density and reducing pore size and porosity. Sandy soils with a small percentage of clay size fraction/mineralogy are inherently less prone to this form of deformation compared to loamy, clayey and silty soils.

Table 3 summarises the inherent risk of compacting soils with the choice of machinery and handling practice options owing to the degree of trafficking by the machines over the surface of the soil horizons.

Soil Storage

As indicated in **Table 4**, the practice of storing (stockpiling) stripped soils in mounds (often referred to as ‘bunds’) prior to their replacement has a high risk of causing additional compaction as well as the degradation of the soil’s biological functions.

The degree of effect depends on the machinery and practice used, but also the height of the storage mound (i.e. depth of soil burial), the type (texture) and condition (wetness) of the soils, and the length of time in store (Abdul-Kareem & McRae, 1984; Johnson et al, 1988).

The best practice is to avoid soil storage by direct placing the newly stripped soils on the area to be restored. Where storage is unavoidable, it should be for the minimal time possible, unless longer term storage facilitates the direct placement of the majority of the soil.

Where possible, storage of the high-risk low resilient textural classes (see **Table 2**) should be avoided or at least minimised by limiting the height of mounds to less than 3m.

Machinery Combination & Handling Practice (see Part Two)	Dry Soil Condition	Wet Soil Condition
Excavator – Dump Truck Using Bed/Strip Practice ^{1 2} (Sheets A & D)	Low	High
Excavator – Dump Truck Using Windrow/Peninsular Practice ¹ (Sheet E)	Low/moderate	High
Bulldozer – Dump Truck Using Windrow/Peninsular Practice ^{1 2} (Sheets F & H)	Moderate* - High	High
Hybrid Excavator - Bulldozer – Dump Truck Using Modified Layer by Layer ² (Sheet K)	Moderate*	High
Bulldozer – Dump Truck Using Modified Layer by Layer Practice ^{1 2} (Sheets I & J)	Moderate* - High	High

* With Low Ground Pressure Bulldozers; ¹ = soil stripping; ² = soil replacement

Table 3: Relative Risk of Significant Compaction During Soil Stripping & Replacement

It has become standard practice for topsoil mounds to be restricted to a maximum height of 3m and 5m for subsoils (Natural England, 2021). Where single mounds have different soil types, they should be kept separated by geotextile or other suitable means. In the case of particularly large mounds with long storage durations, it may be acceptable for the subsoil to be covered with a layer of topsoil to its natural depth and utilised for landscape, agricultural or amenity purposes.

The above should be taken into account in the SRMP by the professional soil advisor.

Efficacy of Soil Recovery - Variable Soils and Mixing

Table 5 summarises the inherent efficacy of recovering the soil resources according to the choice of machinery and handling practice options. This is related to the ease of ability to see and react to changes in soil type and thickness of soil horizons (i.e., patterned ground), and the relative risk of soil horizon mixing due to trafficking (see Supplementary Note 5).

Relative Susceptibility to Rainfall Delays

The inherent susceptibility of the operations to significant programme delays following rainfall events due to extensive exposed soil surfaces during soil stripping and soil replacement in the absence of a vegetation cover is summarised in **Table 6**.

Smearing of the exposed surface of the soil (known as 'soil sealing') using a bulldozer blade or excavator bucket to reduce water infiltration is a temporary action widely practiced. It is deployed where soil surfaces are likely to be exposed to rainfall events and when soil handling has been suspended. However, this is likely to require remedial decompaction/cultivation measures on the resumption of operations.

The better practice, and that given in the guidance in **Part Two**, is to ensure bare soil surfaces are not exposed to rain events. However, in doing so it is imperative that the completed soil surfaces are cultivated, seeded or planted without delay and before the onset of prolonged wet conditions.

Machinery Combination & Handling Practice (see Part Two)	Direct Placement	Storage in Single Tier Low Mounds	Storage in Multi-Tier Mounds
Excavator – Dump Truck Using Bed/Strip Practice ^{1 2} (Sheets A & D)	Low	Moderate	High
Excavator – Dump Truck Using Windrow/Peninsular Practice ¹ (Sheet E)	Low/moderate	Moderate	High
Bulldozer – Dump Truck Using Windrow/Peninsular Practice ^{1 2} (Sheets F & H)	Moderate* - High	Moderate* - High	High
Hybrid Excavator - Bulldozer – Dump Truck Using Modified Layer by Layer ² (Sheet K)	Moderate*	Moderate*	High
Bulldozer – Dump Truck Using Modified Layer by Layer Practice ^{1 2} (Sheets I & J)	Moderate* - High	Moderate* - High	High

* With Low Ground Pressure Bulldozers; ¹ = soil stripping; ² = soil replacement

Table 4: Relative Risk of Significant Compaction of Stored Soils

Machinery Combination & Handling Practice (see Part Two)	Reactive to Changes in soil type, thickness, patterned ground	Risk of Soil Horizon Mixing
Excavator – Dump Truck Using Bed/Strip Practice ^{1 2} (Sheets A & D)	High	Low
Excavator – Dump Truck Using Windrow/Peninsular Practice ¹ (Sheet E)	High	Low
Bulldozer – Dump Truck Using Windrow/Peninsular Practice ^{1 2} (Sheets F & H)	Low	High
Hybrid Excavator - Bulldozer – Dump Truck Using Modified Layer by Layer ² (Sheet K)	High/Low	Low/High
Bulldozer – Dump Truck Using Modified Layer by Layer Practice ^{1 2} (Sheets I & J)	Low	High

¹ = soil stripping; ² = soil replacement

Table 5: Reactiveness to Changes in Soil Characteristics & Risk Soil Horizon Mixing

Further information on the geographic based risk of seasonally wet soil conditions is given in the Supplementary Note 4, which also includes an established protocol for the stoppage and restart of operations due to rainfall events (according to the duration and intensity of rainfall events).

The Deployment of Earth-moving Machinery & Handling Practices

Whilst all combinations of earth-moving machinery and handling practices could be used to strip, store and replace soil material, as demonstrated above, there are inherent differences in the degree of risk for the delivery of the intended after uses, and soil functioning and ecosystem services according to the choice made. This is primarily due to the degree of significant compaction affecting the ability of the replaced soil profile to function in the required manner, but also ones of risk of programme delays due to weather and poorer efficacy in soil resource recovery.

In terms of soil textural class, the minimal information that should be available for all schemes, simplistic choices can be made according to the relative resilience to compaction of damaging soil structure (**Table 7**).

For the reasons set out above, the excavator-dump truck combination and bed/strip practice (**Part Two**, Sheets A & D) has the lowest risk of all the options and is the most suitable for all soil texture resilience categories. Because of higher intrinsic risk due to greater trafficking of machines on the soil surfaces the windrow handling practices, using either excavators (Sheet E), low ground pressure bulldozers (Sheets F & H) or the 'hybrid' excavator-bulldozer combination (Sheet K), restricts their suitability to soils of a moderate and high resilience. However, this level of risk in using the bulldozer combination is dependent on the soils being and remaining in a dry condition throughout the soil profile being handled and for the duration of the work.

In England and Wales where agricultural land is to be stripped of its soils and the after use is to be for agricultural production, it too is a factor in the choice of machinery and practices. To achieve sustainable agricultural production, maintain flexibility in the land use and resilience to climate change, the soil resources and their functional attributes on reclamation are to be conserved as much as possible. In the past a distinction was sometimes made between Agricultural Land Quality Grades

Machinery Combination & Handling Practice (see Part Two)	Ability to Maintain Transpiring Vegetation Cover for Soil Stripping	Ability to Progressively Establish Vegetation Cover on soil Replacement	Inherent Risk of Delay in Operations for Soil Stripping/Replacement
Excavator – Dump Truck Using Bed/Strip Practice ^{1 2} (Sheets A & D)	High	High	Low/Low
Excavator – Dump Truck Using Windrow/Peninsular Practice ¹ (Sheet E)	High	NA	Low/NA
Bulldozer – Dump Truck Using Windrow/Peninsular Practice ^{1 2} (Sheets F & H)	High	Low	Low/High
Hybrid Excavator - Bulldozer – Dump Truck Using Modified Layer by Layer ² (Sheet K)	High	High	Low/Low
Bulldozer – Dump Truck Using Modified Layer by Layer Practice ^{1 2} (Sheets I & J)	High	High	Low/Low

¹ = soil stripping; ² = soil replacement

Table 6: Inherent Risk in Operational Delays Due to the Ability to Maintain and Quickly Establish a Vegetation Cover

Soil Texture Inherent resilience of Soil See Table 1	Machinery & Handling Practice (assuming soils are in dry/non-plastic condition and not stored)		
	Increasing Risk of Soil Compaction ->		
High Resilience - Low Risk	ExDt-Bed ^{1 2}	ExDt-Wind ¹ / Hybrid-Wind ²	BuDt-Wind ^{1 2} / BuDt-Mod Layer ^{1 2}
Medium Resilience - Moderate Risk	ExDt-Bed ^{1 2}	ExDt-Wind ¹ / Hybrid-Wind ²	
Low Resilience – High Risk	ExDt-Bed ^{1 2}		

Key: Machinery Combinations & Soil Handling Practices (also see Part Two):

¹ = soil stripping; ² = soil replacement

ExDt-Bed = Excavator – Dump Truck using Bed/Strip Practice (Sheets A & D)

ExDt-Wind = Excavator – Dump Truck using Windrow/Peninsular Practice (Sheet E)

BuDt-Wind = Low ground pressure Bulldozer – Dump Truck using Windrow/Peninsular Practice (Sheets F & H)

BuDt-Layer = Low ground pressure Bulldozer – Dump Truck using Modified Layer by Layer Practice (Sheets I & J)

Hybrid-Layer = Excavator for subsoil & Low ground pressure Bulldozer for topsoil – Dump Truck using Modified Layer by Layer Practice (Sheet K)

Table 7: Most likely suitable machinery & soil handling practice

1, 2 & 3a (i.e. Best & Most Versatile (BMV), MAFF, 1988) and 3b, 4 & 5 (i.e. non-BMV) as to which standard of restoration was applied (Paragraphs 3.1 & 3.2, Schedule 5, Town & Countryside Planning Act 1990, UK Government 2021b).

Current government policy is that all reclamation (restoration and aftercare) agricultural schemes should be to high standards. For agricultural after uses, the best available practice (i.e. least risk) is using the excavator-dump truck combination in conjunction with the bed system (Sheets A – D) which should be used wherever possible irrespective of land quality (Welsh Assembly Government, 2004). With the anticipated effects of climate change on soils (Keay et al, 2013; Welsh Government, 2020), it is important the soil resource per se is conserved whatever its quality grading because of the range of ecosystem services it might provide in addition to agricultural production, for example water storage, flood mitigation, carbon storage and greenhouse gas regulation etc. Where alternative options are proposed for agricultural land, the reasons need to be justified and agreed with the planning authority and the statutory advisors (Natural England & Welsh Government), along with any remedial measures to be in place, and set out in the Soil Resource & Management Plan.

Justifications might include constraints on the safe operation of machinery (eg gradient, complex topography), soil profile attributes (e.g. shallow profile, excessive stoniness, massive apedal soil structure).

For forestry and woodland, in the recent past there have been strong recommendations for the use of excavators and dump trucks in site reclamation (Moffat & Bending, 2006; Moffat, 2014). Hence, it is recommended that the general use of excavators and dump trucks deploying the bed system of soil stripping and replacing (Sheets A - D) woodland soils is adopted in preference to others. Where alternative options are proposed for forestry/ woodland, the reasons need to be justified and agreed with the planning authority with advice from the statutory advisors (Forestry Commission, Natural England & Welsh Government) as

appropriate, along with any remedial measures to be in place, and set out in the Soil Resource & Management Plan.

Except for BMV land, there are no current policy expectations for reclamation to non-agricultural land, such as amenity, biodiversity and habitat recreation schemes (Bradley et al, 2006) and the machinery and handling practices to be deployed. For non-agricultural after-uses on lower quality land, it is recommended that the selection is based upon the soil texture/resilience model set out above in **Table 2**, and as appropriate, the more refined version of Askew (2020). The reasons for the selection along with any remedial measures to be in place should still be justified and need to be agreed with the planning authority and the statutory advisors (as appropriate). These should be set out in the Soil Resource & Management Plan. For BMV soils that are to be reclaimed for non-agricultural uses, the expectation is that the soils will be restored to their former capability (ALC Grade) (Paragraph 040, UK Government, 2014).

Remedial Treatment of Compaction

Where there is a risk of significant compaction occurring through the choice of machinery/handling option deployed and/or soils have been handled in sub-optimal wetness conditions there will be reliance on subsequent remedial treatment to achieve the intended after use and services.

Many former mineral workings have been backfilled with inert waste. Remedial treatments of the infill, by digging or ripping, may not be advisable where these are not to be part of the replaced soil profile, and this should be covered in the SRMP. There may also be 'capping layers', required by the Environment Agency and Natural Resources Wales, which must not be disturbed. The treatment of former silt-lagoons needs particular careful consideration and consultation with a geotechnical specialist where there is a possibility of breaking through a dewatered and stabilised upper material into the saturated underlying lower material.

Two commonly used methods for remedying compaction caused are the use of tines drawn through the soil layer (often referred to as 'ripping')

or digging using an excavator bucket (Sheets N & O). Their effectiveness is dependent on the tools reaching the compacted layer within the process of the replacement of soils. Hence, the use of standard agricultural ploughing and subsoiling methods are largely limited to the topsoil layer in their application and efficacy during the soil replacement process. What is needed is specialist equipment of the SIMBA bespoke types (SIMBA, 1983).

The actions of ripping and digging serve to break down the compacted soil mass into smaller lumps creating air spaces between them and/or creating fissures (planes of weakness and cracks). They do not result in the enlargement of the compressed larger soil pores per se which is a matter of soil development processes, such as swelling and shrinkage in clayey soils with changes in water content, plant root penetration and microbial activity over a long period of time.

However, the physical cultivation of compacted layers can facilitate these, although its effectiveness may be short lived and less effective than minimising the degree of compaction in the first place through the choice of more appropriate machinery and handling practice.

The effectiveness of both methods (Sheets N & O) are dependent on the soil being in a dry condition in order to be able to 'shatter', thereby creating small lumps of soil and planes of weakness. Soils in a wet (plastic state), particularly those of a finer textured low and moderate resilience (see **Table 2** above), will simply deform and smear around the tines and compress further within the bucket exacerbating the compaction condition. Hence, where the choice of machinery and practice is to rely upon the effectiveness of decompaction to achieve the after use and ecosystem services, the re-laid soils need to be in a dry condition at the time of stripping and storage, and during relaying. Where this is not the case, progressive and costly remedial work over a number of years will have to be relied upon during the aftercare period and beyond when transpiring vegetation can be grown to assist with the drying of the soil profile to facilitate soil decompaction.

Model methods are provided in **Part Two**, Sheets N & O of the guidance for the use of tines and digging with buckets, and their integration into the process of soil replacement. This should be clearly set out in the SRMP as it is often overlooked and is essential if compaction is to be reduced during the reinstatement of the site, particularly when it is at depth and is the only opportunity to do so.

The following sets out the basic options where decompaction, involving a final profile comprising a basal layer, subsoil and topsoil layers, may be needed to achieve the intended after use and ecosystem services:

Option 1: is where the basal layer needs to be treated but is left until the subsoil is placed when both are decompacted together, followed by the decompaction of the topsoil and subsoil layers together (and basal layer) using tines that are long enough. This option is not suited to digging where the soil horizons would be mixed.

Option 2: is where each layer is treated separately by either tines or digging.

Option 3: is where the basal layer is treated or left untreated, followed by the placement of the subsoil and topsoil layers, which are to be decompacted by the use of tines. In the case of deep horizons this option can be limited by the capability of the machinery, the tines or bucket used. This option is not suited to digging where the soil horizons would be mixed.

Removal of Stones and Non-soil Debris

The need for the removal of stones of a particular size and non-soil debris (such as concrete slabs, tree stumps or wire rope) from the reinstated soil profile or from the interface with inert fill may be necessary to facilitate effective decompaction work and enable agricultural tillage operations to take place, as well as to achieve the required standard of reclamation, the intended after use, and provision of ecosystem services. For imported soils (where there is a shortfall), screening may be an option and cost effective.

The options for removal within the placed soil

are limited by where the stone and debris occur. Generally, each affected soil layer will need to be treated separately. This will also determine the options for the treatment of compaction, although the removal operation may also serve at the same time to reduce compaction. Guidance on the deployment of the available methods are given in **Part Two** Sheets L & M. The provisions for this should be set out in the SRMP along with the method to be used, the criteria to be used (eg stone size), along with its operational integration into the soil replacement process.

Cultivations Following Soil Replacement

Additional cultivations may be necessary (such as the creation of a seedbed and reduction in the surface stoniness) following the replacement of the soil profile and completion of remedial works for decompaction and stone/artefact removal. It is expected that these would be of a type relevant to the after use. The specification for these is outside of the scope of this guidance but should be covered in the SRMP. The timing of these finishing cultivations is critical as the replaced soils will be vulnerable to compaction by the trafficking of the machines used, particularly if rainfall events cause the soil to become wet. Importantly, these operations should be undertaken progressively as soon as the replaced topsoil is laid.

The finishing cultivations required following soil replacement are likely to differ between the earth-moving machinery combinations used. With the excavator option and friable soils (Sheet N), the bucket may be sufficient with or without the use of a stone-rake attachment (Sheet L). Where the soil clods to be broken down are too hard, the use of disc or 'crumbler bar' cultivation tools may be necessary. For the bulldozer combinations, secondary treatment by discing is the most likely.

Under-Drainage

Guidance on the installation of under-drainage is outside of the scope of **Part Two**. Where under-drainage needs to be installed, this usually takes place during years 1 or 2 during the aftercare period following any settlement of the replaced soil profile. There have been schemes that have installed under-drainage progressively using the

'bed/strip' system of soil replacement (Sheet D), however, this may be less satisfactory than the conventional approach. On the other hand, subsequent installation can result in the disruption and compaction of the reinstated soil profiles if undertaken without care and when the soil profile is wet, as often occurs.

Vegetation Cover

It is important for a vegetation cover to be established as soon as possible and in sufficient time before the growing season ends to protect the soil surface and minimise slaking of the loosened soil profile, attenuate surface runoff and to initiate soil recovery processes. The extent of soil replacement should not usually exceed the capability of establishing an effective vegetation cover. It should be undertaken progressively as soon as the replacement operations and final cultivations are completed to avoid the soil surface remaining bare and unprotected by vegetation over the winter with the high risk of loss of soil from wind and water erosion, and the infestation by weeds. Where the earlier than expected deterioration of weather conditions prevent proper preparation the sowing of a temporary (sacrificial) quickly establishing grass cover may be an option. In unavoidable circumstances alternative seeding methods can be deployed, including hydro-seeding and aerial seeding.

Other measures include the installation of cut-off grips and use of biodegradable geotextiles. Where these measures are deployed further remedial treatments may be necessary when operations are undertaken to establish the intended vegetation. Again, all these provisions should be covered in the SRMP.

References

- Abdul-Kareem A W & McRae S G, 1984. The effects on topsoil of long-term storage in stockpiles. *Plant and Soil*, 76, 357–363.
- Askew R, 2020. Chapter 7 – Environmental Topics: 7.4 Soils, pp 119-123. In B Carroll, J Fothergill, J Murphy & T Turpin (eds), *Environmental Impact Assessment Handbook: A practical guide for planners, developers and communities*, 3rd edition. ICE Publishing, London.
- [Bacon A R & Humphries R N. 1987. Deep ripping: A more effective and flexible method for achieving loose soil profiles. In Rainbow, A K M \(ed\). *Advances in Mining Science & Technology 2: Reclamation, Treatment and Utilisation of Coal Mining Wastes*. Elsevier, Amsterdam pp 321-330](#)
- Ball B C & Munkholm L J, 2015. *Visual Soil Evaluation: Realizing crop production with minimum environmental impact*. CABI, Wallingford.
- [Ball B C, Guimarães R M L, Cloy J M, Hargreaves P R, Shepherd T G & McKenzie BM, 2017. Visual soil evaluation: A summary of some applications and potential developments for agriculture. *Soil and Tillage Research*, 173, 114-124](#)
- Bending N A D, McRae S G & Moffat A J, 1999. Soil-forming materials: their use in land reclamation. Department of the Environment, Transport and the Regions. The Stationery Office, London.
- Bradley I, Clarke M, Cooke H, Harris J, Leeds-Harrison P, Mayr T, Towers W, Rodwell J & Gowing D, 2006. Research Report Number 712: Guidance on understanding and managing soils for habitat restoration projects. English Nature, Peterborough.
- [Bransden B E. 1991. Soil protection as a component of gravel raising. *Soil Use and Management*, 7, 3, pp 139-144](#)
- [British Society of Soil Science. Undated. Working with soils series: Professional competency in soil science](#)
- [British Society of Soil Science. 2021. Guidance Document 3 – Working with soil Guidance Note: Benefitting from soil management in development and construction](#)
- [Department of the Environment. 1989. Minerals Planning Guidance 7: Restoration of Mineral Workings \(paragraph 2\)](#)
- [Department of Environment, Food & Rural Affairs. 2005. Guidance for the Successful Reclamation of Mineral and Waste Sites](#)
- [Department of Environment, Food & Rural Affairs. 2009a. Safeguarding Our Soils: A strategy for England](#)
- [Department of Environment, Food & Rural Affairs. 2009b. Construction Code of Practice for the Sustainable Use of Soils on Construction Sites](#)
- [Duncan N A and Bransden B E. 1986. The effects on a restored soil caused by soil moving under different moisture contents. *Applied Geography*, 6, 3, pp 267-273](#)
- Dunker R E, Barnhisel R I & Darmody R G (eds), 1992. *Proceedings of the 1992 National Symposium on Prime Farmland Reclamation*. University of Illinois at Urbana-Champaign, Illinois.
- [Humphries R N, Close, P & Smallshaw R J. 2018. The Selection and Operation of Earth Moving Equipment for the Rehabilitation of Functional Soil Profiles: An updating of the UK guidance. *Journal American Society of Mining and Reclamation*, 2018 Volume 7, Issue 2 pp 1-18](#)
- Humphries R N, Thompson R J K & Heames M D, 2019. Case Study: Appraisal of four soil-based metrics in the establishment of sustainable upland grassland at a mine site in South Wales, United Kingdom. *Journal American Society of Mining and Reclamation*, 8, 3, 1 – 21.
- Johnson D B, Williamson J C & Bailey A J, 1988. 95-109. Response of soil micro-organisms to stockpiling and land restoration, pp 95-109. In, *Land Restoration Investigation and Techniques*. British Opencast Executive, Mansfield.
- Keay C A, Jones R J A, Procter C, Chapman V, Barrie I, Nias, I, Smith S & Astbury S, 2013. Research contract SP1104: The Impact of climate change on the capability of land for agriculture as defined by the Agricultural Land Classification, DEFRA, London.
- MAFF, 1982. Reference Book 441: Techniques for measuring soil physical properties. Her Majesty's Stationery Office, London
- [MAFF. 1988. Agricultural Land Classification of England and Wales](#)
- Moffat A, 2014 Forest Research BPG Note 4: Loose Tipping. Forestry Commission, Farnham.
- Moffat A J & Bending N A D, 2006. Replacement of soil and soil forming materials by loose tipping in reclamation to woodland. *Soil Use and Management*, 16, 2, 75-81.
- [Natural England. 2021. Planning and aftercare advice for reclaiming land to agricultural use](#)
- Reeve M J, 1994. Improving land restoration in Britain by better timing of soil movement, pp 28-37. In, *Proceedings American Society of Mining and Reclamation*. DOI:10.21000/JASMR94030028
- Reeve M J, Heaven F W & Duncan N A, 2000. Evaluation of Mineral Sites Restored to Agriculture. Report 313/50 to the Ministry of Agriculture Fisheries and Food, London.
- SIMBA, 1983. *Handbook for the Operation of Restoration*

Implements. National Coal Board – Opencast Executive, Mansfield.

Spoor G, 2006. Alleviation of soil compaction: requirements, equipment and techniques. *Soil Use and Management*, 22, 2, 113-122.

Spoor G and Foot K J, 1998. Soil compaction alleviation on restored sites. Pp 277 – 286. In, H R Fox, H M Moore & A D McIntosh (eds), *Land Reclamation: Achieving Sustainable Benefits*. A A Balkema, Rotterdam.

[SRUC, 2021. Visual Evaluation of Soil Structure](#)

[UK Government, 2014. Minerals Planning Practice Guidance: Guidance on the planning for mineral extraction in plan making and the application process](#)

[UK Government, 2020a. Health & Safety at Work Act 1974](#)

[UK Government, 2020b. The Quarry Regulations 1999](#)

[UK Government, 2020c. Enabling a Natural Capital Approach \(ENCA\): Guidance](#)

[UK Government, 2020d. Town and Country Planning Act 1990](#)

[UK Government, 2021a. Statutory Instruments 2016: No. 127 - The Wildlife and Countryside Act 1981 \(England and Wales\) \(Amendment\) Regulations 2016](#)

[UK Government, 2021b. Town and Countryside Act 1990](#)

[Welsh Assembly Government, 2004. Planning Policy \(Wales\) - Minerals Technical Advice Note 1: Aggregates - Annex B4: Handling of Soils during Mineral Operations](#)

[Welsh Government, 2020. Capability, Suitability & Climate Programme: Effect of Climate Change on the predictive ALC map of Wales v2](#)

[Wikipedia, 2020. Natural Capital](#)

SUPPLEMENTARY NOTES

Supplementary Note 1

Soils

The starting point in determining the appropriate soil handling strategy and method for the reclamation of particular land uses and soil-based ecosystem services is the description of the original and proposed soil profiles. This information can help to identify the practicability of after uses at the outset when designing a reclamation scheme, whether it is a replication of the original or a novel profile for the intended after use, soil function and environmental and ecosystem service provisions. The same applies when assessing the restoration achievement against the original pre-working soil characteristics.

Soil is the surface covering layer which provides for the land use and ecosystem services such as vegetation cover, food production, and water run-off attenuation. The soil layer can be mineral and/or organic matter in its origin and nature. Soils vary spatially in their functional attributes and capacity depending on the parent material, geological and fluvial processes, time, climatic conditions, and land use history.

Simplistically, the idealised soil is differentiated vertically in profile (see **Figure 1.1**) into distinct or graduated layers (Hodgson, 1997). The upper vegetated 'A' horizon, in soil science terms referred to as the 'topsoil', being the most biologically active with accumulated humified organic matter and is often structurally well developed. The underlying layer(s) 'E' and/or 'B' horizon 'subsoil' layer(s) are often chemically altered parent material. They are less biologically active and structurally developed. The underlying 'C' horizon, from which mineral topsoil and subsoil may have developed, is usually less altered, structured and biologically active, but may be an important part of the functioning soil profile. This layer and underlying unaltered drift/solid geology (if present) lying above the economic mineral layer is usually termed 'overburden' and handled differently from the soil resource as a bulk material to be removed/replaced according to civil engineering practice.

However, in some cases the overburden is of a character that it can be used as substitute soil material (soil forming material, Bending et al, 1999) particularly where there is a historic shortfall because previous land development. In some instances, particularly river terrace sand/gravel deposits, the B and/or C horizons may be considered to be part of the economic mineral deposit and if used a substitute for the lost soil horizons may need to be found. Wherever possible, the supplementary/substitute soil forming material should be treated during handling as if it were a subsoil material.

Beware the use of the terms Topsoil and Subsoil in civil engineering for the geotechnical description of soils is different from that used in soil science and are not inter-changeable.

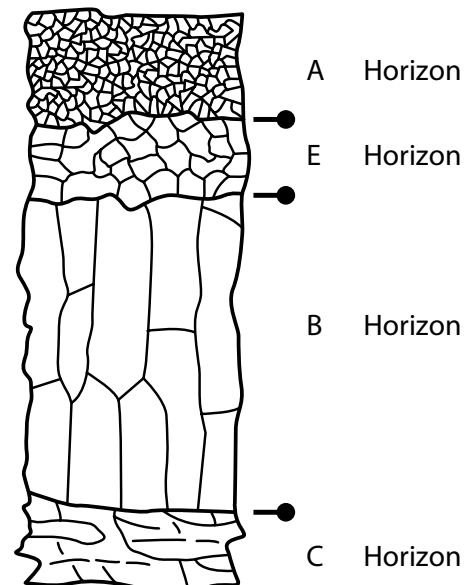

Figure 1.1: An idealised soil profile

Naturally occurring soil profiles in England and Wales have been described in detail and formally classified as to their origin, soil forming processes and functional characteristics (Soil Survey of England & Wales, 1984). Whilst the different soils of the UK have been mapped (some examples are illustrated in **Figure 1.2**), this is usually of not sufficient local detail for devising Soil Resource & Management Plans and operational purposes. Hence, site specific surveys are to be undertaken by qualified soil surveyors (British Society of Soil Science, Undated).

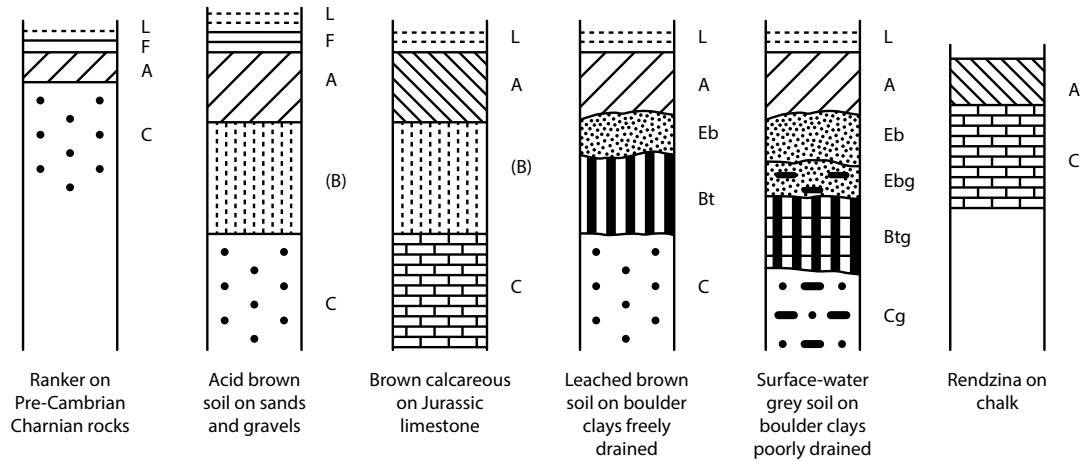

Figure 1.2: Some examples of the variation in soil profiles (L & F surface accumulated organic matter; A = topsoil B&E = subsoil horizons C = 'parent' material)

The soil information to be collected to help inform the landscape plan and reclamation strategy is usually from profiles of up to 1.2m deep (Natural England, 2021). It may include the upper part of the workable mineral or may even be deeper depending on circumstances such as where peat deposits occur. Importantly, the different soil characteristics and functions of the soil horizons within the profile and the underlying material need to be recorded.

Whilst most of the information may be collected during agricultural land quality assessments and can be used without the duplication of effort, more intensive sampling may be needed where there are substantial lateral and vertical variations in soil distribution and where boundaries between soil types need to be defined.

Additional data on soil pH, nutrient status, and organic matter content as both a record of baseline conditions, and for scheme design, such as the identification and management of soils for biodiversity-led after use where, for example lower nutrient topsoils or those soils with a particular pH range may require identification.

Standard field soil survey methods and descriptions should be used (Hodgson, 1997) to include thicknesses of recognisable soil development layers (soil horizons), for which texture and aggregate structure, porosity and size of pores, stoniness and stone sizes, the distribution and rootable depth

of plant roots, colour and staining/deposits, and biological activity (**Figure 1.3**). From these the available water capacity can be estimated as well as the depth to slowly permeable layers can be identified and the Soil Wetness Class assigned (MAFF, 1988). Free- calcium carbonate and soil reaction (pH) and salinity can be determined in the field. Supplementary laboratory determinations may be required for soil organic matter, particle size determinations. Other factors such as gradient, patterned ground and climate will influence current and future potential land use and ecosystem services.

The collection and interpretation of the local circumstances and soil information requires skill and is to be done by experienced soil surveyors. They are able to define the topsoil, subsoil and drift/solid geology layers for the purpose of soil stripping, storage and replacement, and the inherent limitations or qualities for the intended land use and ecosystem services.

The most useful characterisation of soils for the practical purpose of determining their resilience and susceptibility to compaction and the resulting consequences are those of mineral particle size classification (textural) and organic matter content groupings (**Figure 1.4**). Soils with an organic matter content of over 20-25% (depending on clay content) are referred to as 'organic' or 'peaty' and are differentiated from 'organic mineral' soils with

Grid Ref										Proj No										9 8 7 6 5 4 3 2																													
Sub group					Series										Var					Slope					Slope shape					Date					Observer														
Land use										Vegetation										Community QV					Spare																								
Depth										PSC/Peat					Matrix					Mottle 1					Stone					Other																			
Horizon										Hum					CaCO ₃					Mottle 2					Type					Subtype					Grain size mm					Rk					Abund				
Depth										PSC/Peat					Matrix					Mottle 1					Stone					Other																			
Horizon										Hum					CaCO ₃					Mottle 2					Type					Subtype					Grain size mm					Rk					Abund				
Depth										PSC/Peat					Matrix					Mottle 1					Stone					Other																			
Horizon										Hum					CaCO ₃					Mottle 2					Type					Subtype					Grain size mm					Rk					Abund				

0 = None F = Few C = Common M = Many A = Abundant (not concr: not mottles!) V = Very Many (not stones!) X = Extr. Abund (not mottles!)
 VS = Very Small S = Small M = Medium L = Large VL = Very Large B = Boulders

Figure 1.3: Example of soil profile recording card

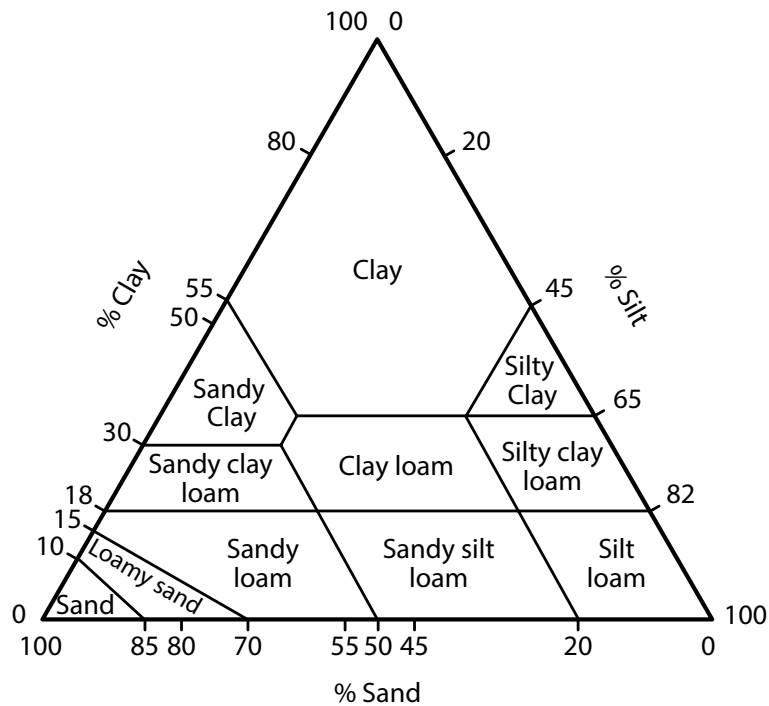

Figure 1.4: Soil mineral particle size (texture) classes

a content of between 6-20% or 10-25%, whereas 'Mineral' soils have a content lower than 6-10% (Natural England, 2008).

Mineral soils are categorised into 11 main particle-size classes according to the proportion of sand, silt and clay sized mineral particles. Sands are further divided into fine, medium, and coarse fractions.

In terms of resilience and susceptibility to compaction, the clay content of the soil largely determines the change from a solid to a plastic state (the water content at which this occurs is called the 'plastic limit' (MAFF, 1982)). This is the point at which increasing soil wetness has reduced the cohesion and shear strength of the soil.

Sands, gravel and peat do not exhibit plasticity and have no plastic limit, silts only occasionally, whereas clay materials possess a high degree of plasticity. Mineral soil textures can be grouped, according to clay content (Reeve, 1994), to represent a descending hierarchy of risk from most to least:

- Soils <10% clay particle size fraction – sand class (often referred to as 'very light soils') – most resilient & least susceptible
- Soils 10-18% clay particle size fraction – loamy sand, sandy loam, sandy silt loam, silt loam classes (often referred to as 'light soils')
- Soils 18-27% clay particle size fraction – sandy clay loam, clay loam, silty clay loam classes (often referred to as 'medium soils')
- Soils >27% clay particle size fraction – sandy clay, clay loam, silty clay, clay classes (often referred to as 'heavy soils') – least resilient and most susceptible.

Askew (2020) sets out a similar soil texture categorisation of risk (resilience), this is reproduced in a simplified form in **Part 1, Table 1**.

The relative potential of the soil groupings to be in a plastic state when sufficiently wet is a significant consideration in the timing of handling of soils and in the need for remedial treatment. Soil wetness is a function of climate (especially rainfall and evapo-transpiration), soil (texture, structure, porosity, organic matter content), and site conditions such as

gradient and landform, flood risk and groundwater conditions. Indicative soil textures (top- and subsoil) and likely ranges in Soil Wetness Classes for England and Wales are shown on the National Soil Resource Institute's LandIS web pages (National Soil Resources Institute, 2020); also see Supplementary Note 4 for more about soil wetness.

References

Bending N A D, McRae S G & Moffat A J, 1999. Soil-forming materials: their use in land reclamation. Department of the Environment, Transport and the Regions. The Stationery Office, London.

[British Society of Soil Science, Undated. Working with soils series: Professional competency in soil science](#)

Hodgson J M, 1997. Soil survey field handbook: describing and sampling soil profiles. 3rd Edition. Soil Survey and Land Research Centre, Silsoe, Cranfield University.

MAFF, 1982. Reference Book 441: Techniques for measuring soil physical properties. Her Majesty's Stationery Office, London

[National Soil Resources Institute, 2020. LandIS: The Land Information System](#)

[Natural England, 2008. Soil texture \(TIN037\)](#)

[Natural England, 2021. Planning and aftercare advice for reclaiming land to agricultural use](#)

Soil Survey of England & Wales, 1984. Soils and their Use. Bulletins 10 – 15. SSEW, Harpenden.

Supplementary Note 2 Soil Resource & Management Plan

As soils are important Natural Capital providing a range of essential environmental and ecosystem services (UK Government, 2020), a Soil Resource & Management Plan (SRMP) is likely to be required for most planning consents for mineral developments (DEFRA, 2005; UK Government, 2014; British Society of Soil Science, 2021c; Natural England, 2021).

The purpose of the SRMP is to ensure the soil capital is clearly identified as a pre-working baseline, not unduly degraded or lost and that the after uses are sustainable and sufficiently resilient. Without an appropriate SRMP there is a risk of losing, damaging or contaminating the soil resource, and failure to identify opportunities and constraints for site working and reclamation design at the outset.

The SRMP should normally be prepared to support a planning application for mineral extraction, for example as part of an environmental statement. The detail within the SRMP will vary between mineral sites and their context and is to be agreed prior to determination with the Mineral Planning Authority with advice from their statutory advisors Natural England, Welsh Government and the Forestry Commission. Early consultation as part of the pre-application process is advisable. The approved SRMP should be a condition of the planning consent and considered as a 'live' document that is reviewed and updated periodically as appropriate during the operational development and reclamation (restoration and aftercare) of the scheme.

The scope of the information to be needed is set by Natural England (2021) in their Planning and Aftercare Advice for Reclaiming Land to Agriculture. It can be used as a basis for other land uses and reclamation schemes. The now archived DEFRA (2004) Guidance for Successful Reclamation of Mineral and Waste Sites also provides useful checklists.

The British Society of Soil Science (2021a & 2021b) also provides guidance on the background and

field collection of soil and related climatic data as does the National Soil Resources Institute's (2020) information system.

References

[British Society of Soil Science, 2021a. Soils and Land Quality: Microsoft Word - Soils and Land Quality - July 2021.docx](#)

[British Society of Soil Science, 2021b. Guidance Document 1: Working with soil guidance note on assessing agricultural land classification surveys in England and Wales](#)

[British Society of Soil Science, 2021c. Guidance Document 3 – Working with soil Guidance Note: Benefitting from soil management in development and construction](#)

[DEFRA. 2005. Defra Guidance for Successful Reclamation of Mineral and Waste Sites](#)

[Defra. 2020. Enabling a Natural Capital Approach Guidance](#)

[National Soil Resources Institute, 2020. LandIS: The Land Information System](#)

[Natural England, 2021. Planning and aftercare advice for reclaiming land to agricultural use](#)

[UK Government, 2014. Minerals Guidance: Restoration and aftercare of minerals sites, paragraph 040](#)

Supplementary Note 3 Soil Compaction

Soil compaction is the term used to describe a condition where the soil particles have been compressed tightly together to give a higher packing density/bulk density (**Table 3.1**) than would be expected for the soil-type or particular horizon within the soil profile (Hodgson, 1997). Soil density has a profound effect on the drainage and aeration of soils, and hence on plant root growth and soil ecology, soil structural development, and overall functioning, including greenhouse gas emissions.

Soil types differ in their inherent packing density, but also within their profiles, with the upper horizons having lower densities than their lower horizons because of a greater porosity. Compression can reduce the porosity and pore size resulting in an increase in volumetric density and hence soil strength. The increase can significantly reduce plant root growth and/or soil infiltration/drainage and aeration, thereby reducing productivity and the recovery of soil function after soil handling, besides causing waterlogging and increasing runoff.

Compaction is typically caused when soils are traversed by heavy machinery or trampled by livestock, but also in the handling (stripping, stockpiling and transporting) of soils. Soils are generally most susceptible to compaction in a wet condition when soil strength and resistance to compression are at their lowest (see Supplementary Note 4).

The potential for compacted soils to occur in restored mineral workings is particularly high and can inhibit the achievement of the planned land use and provision of the intended ecosystem services. In some circumstances, like the modification of drainage characteristics for some wetland creation schemes, here compaction within the soil profile or underlying material for a higher density/lower porosity can be beneficial.

The packing density of soils is a useful indicator of soil strength and its relative compaction (Hodgson, 1997; Ball & Munkholm, 2015; Ball et al, 2017). Alternatively, penetrometers can be used to measure soil strength (MAFF, 1982), although their interpretation can be confounded by a number of soil factors such as its water content and stoniness.

Packing Density Category~	Indicative Bulk Density (g/cm ³)~
Low* – single grain loose when moist / weak strength when moist	<1.40
Medium – moderately firm with many macropores	1.40 – 1.75
High – single grain compact / firm to strong strength with few macropores#	>1.75

~ see Hodgson (1997); *rare in clay & sandy clay mineral soils; # rare in mineral topsoils unless clay/clay loam mineral soils, also rare in organic minerals soils & peat

Table 3.1: Packing Density Categories and Corresponding Typical Bulk Densities in Mineral Soils

Bulk density measurements are more accurate, and whilst requiring laboratory determination (MAFF, 1982), they can be used to verify field visual assessments.

Soils with relatively high packing/bulk densities naturally occur where they are of a fine texture and/or have weak structural development. In the subsoil layers, a high density may not necessarily indicate compaction, but other structural characteristics of the soil. For the underlying C-horizon material, a high density would generally be expected. The occurrence of these profile characteristics should be taken into account in the SRMP. Professional soil surveyors can advise on the comparative packing densities of the in situ and reinstated soils, and on the potential for compaction and where compaction occurs (British Society of Soil Science, Undated).

Minimising Compaction

The complete avoidance of the compression of soils during soil handling (striping, storing and replacing soils) in mineral workings is unrealistic. However, measures to minimise significant increases in packing density (compaction) occurring can be deployed.

The main cause of compression is the traversing of soils with earth-moving machinery. The heavier the machines, the greater is the potential for compaction. Whilst machines differ in size and contact pressures (loaded and unloaded), it is usually the choice of machinery combination and handling practices that determine the degree and extent of compaction. The frequency of traversing the soils and soil condition, with the greater potential for significant compression occurring when wet (plastic), are likely to be contributing factors, but also can be the action in the loading of soils, loaded soils being carried, and the mounding of soils in stores. Consequently, in most circumstances, the best option available for soil handling is that based on excavator and dump truck and the bed/strip handling practice (Bransden, 1991; Moffat & Bending, 2006; Moffat, 2014).

Treating Compaction

Whilst natural physical and biological processes can over a very long period of time reduce induced

higher soil packing density closer to their original state, remedial treatment is needed to accelerate the processes of soil recovery.

Compacted materials can be broken up by physically 'digging' or 'ripping' or cultivating by mechanical means (Spoor & Foot, 1998; Spoor, 2006). Whilst this is referred to as 'de-compaction', the actual result is the reduction of the soil mass into smaller masses ('clods' (>10 cm in size) or 'fragments' (<10 cm)) which themselves remain in the compressed state. The effect in the short term (as a surrogate for natural soil structure) can facilitate plant root penetration, drainage and aeration through the voids between the soil clods/fragments and any planes of weakness created.

The longevity of such a surrogate for natural soil processes is dependent on soil characteristics (texture, aggregate stability) and biological activity such as plant roots or the addition and incorporation of organic matter to maintain the voids and planes of weakness. Subsequent practices which recompact the soil (which can easily reoccur in the short term through machinery trafficking and livestock) during the aftercare period need to be avoided.

Where compaction is identified or expected within the replaced soil profile and is of consequence for the intended land use and ecosystem services, treatment should be scheduled during or after the replacement process as it is completed; where this is omitted the only and often less satisfactory option (if agricultural equipment is relied upon) is for it to be undertaken from the soil surface during the aftercare period.

Treatment of compaction before soil replacement is unlikely to have any subsequent benefit as recompaction of the loosened clods/fragments is likely to take place in subsequent handling. For other reasons, such as the ease of recovery of the soil from storage mounds, some decompaction of the soil in situ may be achieved.

The effectiveness of loosening compacted soil layers is dependent on the tools and practices used, and on the soil type and its wetness

condition. The two principal tools used are digging buckets operated by excavators or tines drawn by bulldozers. Both can be effective in promoting plant root penetration, drainage and aeration at least in the short term, but are dependent on the practice used, discipline in application, and soil condition for their effectiveness. Both options can result in uneven soil surfaces which for agricultural uses may need secondary cultivation treatment such as the use of discs and/or the use of crumbler-bars. The cultivated soil should be sown/planted as soon as possible as the decompacted profiles will have a low bearing capacity until natural settlement has taken place (usually over the first winter). The choice of the finishing of the completed soil surface can be a matter of operational preference and experience, the intended land use, time taken and cost, and gradient limitations.

Decompaction by digging subject to the capability of the excavator and size of bucket, can be used on completed soil profiles where the entire profile is to be dug or dug to a particular depth. The digging of the final profile might be an option (Options 1 & 3) where the mixing of surface and underling soil horizons is not of concern. It is to be carried out as sequential retreating strips across the land to minimise recompaction as shown in Part Two, Sheet N. The digging of the surface layer to a limited depth can be used in combination with stone removal from the upper soil layer when specialist stone-rake buckets with rows of stub-tines are used.

The same digging treatment can be deployed to individual soil horizons (Option 2), where digging of the final profile is not an option because of soil mixing (see Supplementary Note 5), as they are laid and where stones/non-soil debris are to be sequentially removed without the excavator working on the soil layers.

The ripping with tines can also be used on completed profiles (Option 3) and/or sequentially to treat individual horizons (Options 1 & 2) as the profile is built up as shown in **Part Two, Sheet O**. It is to be carried out as sequential retreating strips across the final profile or individual horizons depending on the potential effectiveness of the tine size and configuration and capability of the pulling

power unit (Binns, 1983; Bacon & Humphries, 1987; Spoor & Foot, 1998). Importantly, the configuration of the tines must at least include tines that are centred on the bulldozer's caterpillar tracks to treat the recompaction caused.

Again, with the ripping of individual soil horizons as they are laid (Option 2), there is a risk of recompaction by where the bulldozer is working on overlying successive layer(s). To rectify this decompaction from the surface of the overlying layer or the final surface may be required (Bacon & Humphries, 1987; Spoor & Foot, 1998). The length of the tines determine the potential depth to which decompaction might take place, although the actual effective depth because of soil heave dragging on the tool bar, is less and needs to be taken into account when determining the option to rip from the final surface.

The lateral effectiveness of the tines is determined by their spacing and operating depth, the wider the spacing the less effective they are in breaking up compacted soil into clods/fragments and creating planes of weakness. As the number of tines affect the drag and the load being carried, and hence the power needed, the addition of wings enables a wider spacing and hence fewer tines (Binns, 1983; Spoor & Foot, 1998), provided that the tines are operating at optimal depth.

There is nothing wrong with using straight non-winged tines if they are close enough and can be pulled by the bulldozer or there is a sufficient number of over lapping of the passes. Experience has shown that to achieve consistent decompaction that is comparable with digging, overlapping parallel passes are required and this is more effective than other patterns such as 'cross-ripping' (Spoor & Foot, 1998).

The mode of action of the tines as they are drawn through the compacted layer is to create lateral forces that radiate in front of the tine that shatter the surface of the soil and deeper radiating forces that uplifting the soil mass and create fissures and planes of weakness (Spoor & Foot, 1998). The shallower the ripping process the less uplift and the closer the tines need to be to break up the soil. With

deeper ripping, the wider spaced they can be and this may be necessary to reduce the drag on the bulldozer unit.

With the use of both methods, the depth to the uppermost compacted layer may be the determining factor in the realisation of particular land uses and ecosystem services. In some cases, this will be at depth in the profile, whereas in others it will be shallower. Hence, the digging/ripping, final or sequential treatment being adopted needs to be co-ordinated with the requirement and the capability of the equipment being used and the intended afteruse and soil functions and environmental/ ecosystem services to be provided.

Historically, there is a poor record in achieving the adequate treatment of soil compaction. This has been mainly because of :

- i) the inadequacy and poor condition of ripping equipment
- ii) lack of knowledge of how to use the equipment effectively and/or
- iii) the lack of supervision, and
- iv) its deployment when soils are too wet to be effective.

Given the importance of soil compaction in relation to soil handling, professional soil surveyors should be consulted on the potential for compaction and the significance (if any) for the intended land use and services to be provided, the effectiveness of decompaction options and practices, and to identify its occurrence and significance in the field (British Society of Soil Science, Undated).

The setting up and operation of the decompaction practice and equipment should be overseen by a competent person with advice from the professional soil surveyors. Where decompaction is important in achieving the intended land use and services, it should be monitored and as work proceeds and adjusting the practice/operation as necessary.

References

[Bacon A R & Humphries R N. 1987. Deep ripping: A more](#)

[effective and flexible method for achieving loose soil profiles. In Rainbow. A K M \(ed\). Advances in Mining Science & Technology 2: Reclamation, Treatment and Utilisation of Coal Mining Wastes. Elsevier, Amsterdam pp 321-330](#)

Ball B C & Munkholm L J, 2015. Visual Soil Evaluation: Realizing crop production with minimum environmental impact. CABI, Wallingford.

[Ball B C, Guimarães R M L, Cloy J M, Hargreaves P R, Shepherd T G & McKenzie BM , 2017. Visual soil evaluation: A summary of some applications and potential developments for agriculture. Soil and Tillage Research, 173, 114-124](#)

Binns W O, 1983. Treatment of surface workings, pp9 – 16. In, Reclamation of Mineral Workings to Forestry, Forestry Commission, Edinburgh.

[Bransden B E, 1991. Soil protection as a component of gravel raising. Soil Use and Management, 7, 3, pp 139-144](#)

[British Society of Soil Science. Undated. Working with soils series: Professional competency in soil science](#)

Hodgson J M, 1997. Soil survey field handbook: describing and sampling soil profiles. 3rd Edition. Soil Survey and Land Research Centre, Silsoe, Cranfield University.

MAFF, 1982. Reference Book 441: Techniques for measuring soil physical properties. Her Majesty's Stationery Office, London

Moffat A, 2014 Forest Research BPG Note 4: Loose Tipping. Forestry Commission, Farnham.

Moffat A J and Bending N A D, 2006. Replacement of soil and soil forming materials by loose tipping in reclamation to woodland. Soil Use and Management, 16, 2, 75-81.

Spoor G, 2006. Alleviation of soil compaction: requirements, equipment and techniques. Soil Use and Management, 22, 2, 113-122.

Spoor G and Foot K J, 1998. Soil compaction alleviation on restored sites. Pp 277 – 286. In, H R Fox, H M Moore & A D McIntosh (eds), Land Reclamation: Achieving Sustainable Benefits. A A Balkema, Rotterdam.

Supplementary Note 4 Soil Wetness

Soil wetness is a major determinant of land use, and environmental and ecosystem services in the UK. It is also a factor in the occurrence of significant compaction arising from handling soils with earth-moving machines and the practices used (Duncan & Bransden, 1986).

Relative soil wetness can range from the waterlogged to moist (mesic) or dry (xeric) depending on rainfall distribution and depth to a water-table and duration of waterlogging. In the UK, soil wetness is largely seasonal with higher evapo-transpiration rates potentially exceeding rainfall in the summer resulting in the soil profile becoming drier where there is vegetation. Whilst soil wetness is largely weather system and equinox (climate) driven, it varies with geographical and altitudinal locations, and importantly the physical characteristics of the soil profile, such as texture structure, porosity, and depth to the water-table and topography including flood risk (MAFF, 1988). The Soil Wetness Class is based on the expected average duration of waterlogging at different depths in the soil throughout the year (days per year), and can be determined by reference to soil characteristics and local climate (MAFF, 1988). The likely inherent wetness and resilience status of a soil should be indicated in the SRMP (see **Part 1, Table 2 & Supplementary Note 1**), reflecting potential risks for soil handling such as low permeability, permanently high groundwater, or a wet upland climate.

Wet soils can also be a result of other circumstances. For example, the interception of water courses, drainage ditches and field land drains. Where these occur, the provisions are to be made in the SRMP to protect the soils being handled and the operational area.

Soils, when in a wet condition generally have a lower strength and have less resistance to compression and smearing than when dry. Lower strength when soils are wet also affects the bearing capacity of soils and their ability to support the safe and efficient operation of machines than when in a

dry state.

In terms of resilience and susceptibility to soil wetness, the clay content of the soil largely determines the change from a solid to a plastic state (the water content at which this occurs is called the 'plastic limit' (MAFF, 1982)). This is the point at which an increasing soil wetness has reduced the cohesion and strength of the soil and its resistance to compression and smearing.

Whilst coarse textured sandy soils are not inherently plastic when wet, they are still prone to compaction when in a wet condition. Hence, handling all soils when wet will have adverse effects on plant root growth and profile permeability, which may be of significance for the intended land use and the provision of services reliant on soil drainage and plant root growth. It may be less so in other circumstances where wet soil profiles, perched water tables and ponding are the reclamation objectives, though drainage control, for example to control flooding, may still be important in these contexts.

In cases of permanently wet soils, such as riverine sites, upland or deep organic soils where there is a persistent high water-table throughout the seasons within the depth of soil to be stripped and/or the soil profile remains too wet, a strategic decision has to be made to be able to proceed with the development of the mineral resource. This may mean alternative and less favourable soil handling practices have to be agreed with the planning authority.

Predicting & Determination of Soil Wetness

There are well established methods to predict and determine soil wetness of undisturbed and restored soil profiles (Reeve, 1994). The challenge has been the prediction of the best time for soil stripping. Models based on soil moisture deficits and field capacity dates for a range of soil textures can provide indicative regional summaries (**Table 4.1**) that can help with planning operations at broad scale but cannot be relied upon in practice for deciding operationally whether to proceed on the ground given the actual variation in weather events from year to year and within years.



Soil Clay Content	Climatic Zones		
	1	2	3
Soil Depth <30cm			
<10%	Mid Apr - Early Oct	Late Mar – Early Nov	Late Mar – Early Dec
10 -27%	Late May - Early Oct	Early May – Early Nov	Early Apr – Early Dec
Soil Depth 30-60cm			
<10%	Late Apr - Early Oct	Mid Apr – Early Nov	Early Apr – Early Dec
10-27%	Late May - Early Oct	Early May – Early Nov	Early Apr – Early Dec
>27%	Late June – Early Oct	Early June – Early Nov	Late May – Early Dec
Soil Depth >60cm			
<10%	Late Apr - Early Oct	Mid Apr – Early Nov	Early Apr – Early Dec
10-18%	Late May - Early Oct	Early May – Early Nov	Early Apr – Early Dec
18-27%	Late June – Early Oct	Early June – Early Nov	Late May – Early Dec
>27	Mid July – Mid Sept	Early July – Mid Oct	Late June – Mid Oct

Table 4.1: Indicative on-average months when vegetated mineral soils might be in a sufficiently dry condition according to geographic location, depth of soil and clay content

The timing of most soil handling operations takes place between April and September. Although in western (Zone 1) and central (Zone 2) areas it typically can be a later start in May with an earlier termination in August. Whilst the return to climatically ‘excess rainfall’ is later in the eastern counties (Zone 3) and can be as late as November/early December, there is a need to maintain transpiring vegetation to keep the soils being handled in a dry as possible condition and to establish new vegetation covers as soon as possible (on replaced soils and storage mounds). Hence, soil handling operations generally need to be completed no later than the end of September (Natural England, 2021), unless appropriate provisions can be assured.

Where data is available, more realistic local and real-time predictions can be made, however, because weather patterns and events differ between and within years, and soils can be vary locally in their condition. Experience has shown that the most practical approach for operations is to inspect the site and soils in question near to/ at the time when soil handling is to take place. Professional soil surveyors can advise on the best time for soil handling (stripping, storage & replacement) and carry out site assessments of soil wetness condition prior to the start of operations.

A Practical Method for Determining Soil Wetness Limitation

During the soil handling season (see Table 4.1 above), prior to the start or recommencement of soil handling soils should be tested to confirm they are in suitably dry condition (**Table 4.2**). The ‘testing’ during operations can be done by suitably trained site staff and reviewed periodically by the professional soil surveyors.

The method is simply the ability to roll intact threads (3mm diameter) of soil indicating the soils are in a plastic and wet condition (MAFF, 1982; Natural England, 2021). Representative samples are to be taken through the soil profile and across the area to be stripped. It is the best available indicator of soils being too wet to be handled and operations should be delayed until a thread cannot be formed. For coarse textured soils which do not roll into threads, a professional’s view as to soil wetness and the risk of compaction may have to be taken.

Table 4.2: Field Tests for Suitably Dry Soils

Soil tests are to be undertaken in the field. Samples shall be taken from at least five locations in the soil handling area and at each soil horizon to the full depth of the profile to be recovered/replaced. The tests shall include visual examination of the soil and physical assessment of the soil consistency.

i) Examination

- If the soil is wet, films of water are visible on the surface of soil particles or aggregates (e.g. clods or peds) and/or when a clod or ped is squeezed in the hand it readily deforms into a cohesive 'ball' means **no soil handling to take place**.
- If the sample is moist (i.e. there is a slight dampness when squeezed in the hand) but it does not significantly change colour (darken) on further wetting, and clods break up/crumble readily when squeezed in the hand rather than forming into a ball means **soil handling can take place**.
- If the sample is dry, it looks dry and changes colour (darkens) if water is added, and it is brittle means **soil handling can take place**.

ii) Consistency**First test**

Attempt to mould soil sample into a ball by hand:

- Impossible because soil is too dry and hard or too loose and dry means **soil handling can take place**.
- Impossible because the soil is too loose and wet means no soil handling to take place.
- Possible - Go to second text.

Second test

Attempt to roll ball into a 3mm diameter thread by hand:

- Impossible because soil crumbles or collapses means soil handling can take place.
- Possible means no soil handling can take place.

N.B.: It is possible to roll most coarse loamy and sandy soils into a thread even when they are wet. For these soils, the Examination Test alone is to be used.

A Rainfall Protocol to Suspend & Restart Soil Handling Operations

Local weather forecasts of possible rainfall events during operations and the occurrence of surface lying water have been used to advise on a day-to-day basis if operations should stop (Natural England, 2021). Single events such as >5mm/day in spring and autumn months, and >10mm/day in the summer have been suggested as more precise triggers for determining soil handling operations (Reeve, 1994). However, in practice the following generic guidelines are often used:

- In light drizzle soil handling may continue for up to four hours unless the soils are already at/near to their moisture limit.
- In light rain soil handling must cease after 15 minutes.
- In heavy rain and intense showers, handling shall cease immediately.

In all of the above it is assumed that soils were in a dry condition. These are only general rules, and it is at the local level decisions to proceed or stop should be based on the actual wetness state of the soils being handled. After the above rain event has ceased, the soil tests in **Table 4.2** above should be applied to determine whether handling may restart, provided that the ground is free from ponding and ground conditions are safe to do so. There can be extreme instances where soil horizons have become very dry and are difficult to handle resulting in dust and windblown losses. In these conditions the operation should be suspended. The artificial wetting of extremely dry soils is not usually a practice recommended but has been successful in some cases.

References

[Duncan N A and Bransden B E. 1986. The effects on a restored soil caused by soil moving under different moisture contents. Applied Geography, 6, 3, pp 267-273](#)

MAFF, 1982. Reference Book 441: Techniques for measuring soil physical properties. Her Majesty's Stationery Office, London

[MAFF. 1988. Agricultural Land Classification Of England and Wales](#)

[Natural England, 2021. Planning and aftercare advice for reclaiming land to agricultural use](#)

Reeve M J, 1994. Improving land restoration in Britain by better timing of soil movement, pp 28-37. In, Proceedings American Society of Mining and Reclamation. DOI: 10.21000/JASMR94030028

Supplementary Note 5 Soil Mixing

The mixing of soil material can be both deleterious and beneficial, depending on circumstances, and if relied upon, needs special consideration of how it is to be achieved in the Soil Resource & Management Plan (SRMP).

Mixing of Soil Horizon Interfaces

The mixing of soil horizons at the interface can occur during soil stripping and replacement operations for several reasons such as, i) the lack of care taken in the operation, ii) failure to identify and communicate the distinction, iii) the physical impress of soil material during trafficking of machines traversing the soil, iv) spillage of soil when tipping and spreading during soil reinstatement, v) the result of decompaction by bucket or tines, but also vi) soil characteristics such as a gradation in change rather than distinct boundary, and vii) variation in horizon thickness and topography.

The significance of soil interface mixing depends on the extent as well as the intended land use and services. Mixing at the interface of soil layers is often beneficial for plant rooting and drainage, which can be impeded where there is an abrupt change in physical properties.

Wholesale Mixing of Soil Materials

Wholesale mixing of soil types and horizons can occur as a deliberate action or unintentionally. Its occurrence can be for various reasons, from being a consequence of poor record keeping of storage mounds, the absence of adequate soil resource plans to the consequence of soil importation schemes where there is a shortfall of soil material. The latter is often associated with long established inert fill and brown-field sites. Where importation of soils is to occur, it should meet prescribed standards (BSI, 2015) and be considered in detail in the SRMP. The former poor practices should be prevented by the adoption of the SRMP and good site oversight practices.

A common misunderstanding that results in soil mixing is the too literal interpretation of the Natural

England (2021) guidance that all topsoil should be stripped to 300mm, and subsoil should be stripped as a single 700mm layer. Soil horizons should be stripped according to their natural occurrence and separately according to their main functional characteristics (see Supplementary Note 1).

The mixing of soil types and horizons is sometimes advocated to 'improve' soil quality, as is the deliberate mixing of top- and subsoil to reduce topsoil fertility and other soil functions to achieve habitat creation schemes. Where this results in the degradation of soil capital, it should be approached with caution and requires evidence of the benefit to be provided in the SRMP before being adopted.

Historically, more effective than soil mixing has been the substitution of intractable soil horizons with other material, particularly soil forming material from within a site's geological horizons (Bending et al, 1999).

There are instances where the mixing of soil types and horizons are largely unavoidable because of the machinery used and spatial characteristics of the soils. Examples include thin lithomorphic soils on rock deposits and small-scale mosaics in warp and periglacial soils. Because of the practical limitations in recovering the individual thin soil horizons, the surface and sub-surface materials are often stripped together as a single layer, as are the lateral components of mosaics.

In all of the above situations, the professional soil surveyor should have identified these and advised in the SRMP how they are to be treated for stripping, storage and replacement to achieve the intended land use, soil functioning and ecosystem services.

References

Bending N A D, McRae S G & Moffat A J, 1999. Soil-forming materials: their use in land reclamation. Department of the Environment, Transport and the Regions. The Stationery Office, London.

[British Standards Institute, 2015. BS 3882:2015 Specification for topsoil](#)

[Natural England, 2021. Planning and aftercare advice for reclaiming land to agricultural use](#)

GLOSSARY OF TERMS

Apedal

No observable soil particle aggregation and lines of weakness in soil mass.

Basal layer

Unweathered material or fill/capping layer below soil layer not considered to be part of the soil profile/resource.

Clod

An artificial and less stable aggregation of soil particles ranging in sizes and shapes, can be a fragment of a ped.

Ecosystem services

The many benefits to humans provided by the natural environment and from healthy ecosystems, for example, extreme weather mitigation, flood control, clean drinking water, the decomposition of wastes, productivity of food and fibres, human mental and physical well-being.

Field Capacity

The maximum amount of soil water held in the soil after excess water has drained away.

Field Capacity Days

The number of days when the soil moisture deficit is zero.

Natural Capital

The world's stock of natural resources, which includes geology, soils, air, water, and all living organisms.

Ped

Natural stable aggregation of soil particles ranging in sizes and shapes (units of soil structure).

Reclamation

A term encompassing both restoration (the reinstatement of soils) and aftercare stages.

Soil consistency

The cohesion/adhesion of soil particles within the peds giving the characteristic of strength (resistance to crushing/deformation (ranging from loose, weak, firm, strong to rigid)).

Soil forming material

Non soil materials usually derived from mineral wastes, such as overburden materials and uneconomic geological materials encountered during quarrying or mining, that have the potential to turn into soils over time.

Soil function

Includes the physical support for plants and soil organisms, attenuation and drainage, water supply and purification, nutrient accumulation and cycling.

Soil sealing

The temporary careful compaction/smearing of a soil surface by a bulldozer or excavator to reduce the infiltration of precipitation and the wetting of the soil profile.

Soil plastic limit

The water content at which soil material becomes plastic (mouldable) and prone to compression and smearing. Although the plastic limit is not manifest in sandy soils, they are prone to compression at high water contents.

Soil structure

The shape (granular to prismatic/platy), size (fine to very coarse) and degree of aggregation (weak, moderate, strong) of soil particles into structural units (peds) and voids, and their spatial arrangement.

Soil texture

The size distribution (sand, silt & clay sized particles) of less than 2mm fraction of soil material.

Soil Textural Class

Eleven main groupings of soil particle distributions according to the proportions of sand, silt and clay sizes.

Soil wetness

And 'wet soil', a generic term to denote water content at or above the soil's plastic limit.

Soil Wetness Class

Six groupings of the depth to (slowly permeable/compacted layer) and duration of waterlogging in the soil profile.

Subsoil

The physio-chemically and biologically altered layers below the topsoil that are functioning parts of the soil profile, in some cases this includes part of the parent rock/drift materials.

Topsoil

The uppermost and most physically and biologically altered horizon, excluding organic litter layer, of undisturbed soil profiles.

GOOD PRACTICE GUIDE FOR HANDLING SOILS

In Mineral Workings

PART TWO: Methodology

- Sheet A -

Soil Stripping with Excavators and Dump Trucks
– Sequential Bed/Strip Practice

Author: Dr R N Humphries CBiol CSci FRSB FBSSS FIQ
- Blakemere Consultants Ltd & Celtic Energy Ltd

Supporting artwork was provided by R Shelton (H J Banks & Co)
and D Fisher (Blue Room Graphics Ltd).

Preface

The purpose of Sheet A of the updated guidance is to provide a model method of best practice where excavators and dump trucks are to be used to strip soil using the sequential ‘bed’/strip by strip practice.

The guidance is intended for use by planning officials, statutory consultees, mineral operators and their supporting teams and specialist consultants, and earth-moving contractors, their site supervisors and machine operators.

Successful soil handling schemes are dependent on the soil resources being clearly identified and the conditions in which they are to be handled. This information should be contained in the Soil Resource & Management Plan (SRMP) and communicated to those involved in its implementation.

Key issues to be addressed are:

- i) Avoiding conditions when soils are wet/plastic during handling
- ii) The minimisation of soil compaction caused by trafficking and soil wetness
- iii) Using appropriate remedial treatments where these are necessary
- iv) Minimising soil loss, and mixing of soil layers or different soil types.

The SRMP should specify the type of earth-moving machinery and soil handling practice, and the soil wetness condition (see Part One of the Guidance) to be deployed to achieve the planned after use, soil functioning, and the environmental and ecosystem services. It is to be communicated in full to all involved and in particular to the supervisors and machine operators by appropriate means; including tool-box talks and site demonstrations. Supervision by trained supervisory staff is essential, as are monitoring and reporting.

The guidance does not specify the size or model of equipment as this is left to the mineral operator and contractor to specify and provide. The machines must be of a kind which are appropriate for the task and the outcomes required, and to be able to carry out the work safely and efficiently.

Should the agreed methodology need to be modified or changed significantly, this should be agreed in advance with the mineral planning authority. The SRMP should include a mechanism whereby unexpected less significant changes can be quickly resolved through consultation between the operator, the planning authority and statutory consultee, and soil specialist.

All persons involved in the handling of soils must comply with all relevant legislation with respect to Health and Safety, in particular the Health and Safety at work Act 1974, and in the case of mineral extraction operations, The Quarries Regulations 1999 and its relevant statutory provisions; in particular those aspects which relate to the construction and removal of tips, mounds and similar structures. These requirements take preference over any suggested practice in this Sheet and the SRMP should have taken these into account.

The users of this guidance are solely responsible for ensuring it complies with all safety legislation and good practice, including the manufacturer’s specifications for the safe operation of the specific machines being used, and that all machines are in a good condition and well maintained and are suitable for the task. It is important that those involved in the operation of earth moving machines are competent and have the necessary training and certification.

Introduction

In this soil handling option, back-acting excavators are used to lift the soil resources and load them into dump trucks for the direct transport to the area being restored or to storage until needed.

The stripping practice involves the sequential separation and removal of the individual layers of soil identified in the Soil Resource & Management Plan (SRMP). It takes the form of advancing vertical slices through the soil profile as successive strips across the soil being removed. Hence the practice is often referred to as the 'Strip' or 'Bed' method.

The upper layer (topsoil) in the strip being removed is lifted first within the safe and efficient operational reach of the excavator boom (which defines the width of each strip). For each subsequent soil layer, if it is to be recovered, the process is repeated until the basal layer (usually overburden or the economic mineral layer) is reached. When the soil resource/profile sequence within the strip is completely removed, the process is repeated on the abutting area to be stripped of soil. The method can also be adopted where only a single soil horizon is to be recovered.

Normally the excavator operates only from on the soil surface with the dump trucks travelling on the exposed lower non-soil layer. This the preferred operating mode of the excavator as there is a better recovery of the particular soil layer on handling. In some circumstances, such as where, i) the topsoil/surface layer has a particularly low bearing capacity and is prone to compaction (such as peat or organic soils), ii) a thin soil layer lies directly on the mineral layer, or iii) access is limited from the bottom of steep gradients, the excavator will need to operate from the exposed 'basal' mineral/overburden layer or a raised access strip.

Similarly, the normal operation of the dump trucks is on the exposed non-soil basal/overburden layer. In cases where the soil horizon has i) a particularly low bearing capacity or ii) where there needs to be enhanced protection of potential archaeological features, the dump trucks may have to operate upon the topsoil which may have to be surcharged.

Advantages & Disadvantages

The advantages of this machinery combination and handling practice are:

- i) When the excavator operates only from on the soil surface, compaction is largely confined to the top-soil (which is ultimately more easily treated) and potentially reducing the risk of severe compaction of the subsurface soil layers where the soil is to be directly placed without storage
- ii) It is easier to see and react to localised changes in soil types and variation in horizon depth
- iii) It is suited to the stripping of thin and 'patterned' soil layers
- iv) It offers the most flexibility in respect of short soil drying periods and likely wet weather as it is less susceptible to stoppages due to soil rewetting as a transpiring vegetation cover can be retained later into the stripping programme. It is particularly suited to northerly and western, and upland locations, and particularly when there are uncertain weather patterns.

The disadvantages are:

- i) It requires skill and discipline in its deployment, and a high level of supervision, being suited to experienced operators
- ii) Without care the bed system may result in a greater mixing of soil horizons
- iii) Steep gradient/complex topographies may limit the safe and practical deployment of this machinery combination and handling practice.

Suitability

The excavator-dump truck combination with the bed/strip handling practice methodology is considered as 'best practice' by Natural England and the Welsh Government for agricultural soils and preferred for all soils. In particular, it is the most suitable of any of the methods available where:

- i) The soil is prone to compaction and where decompaction treatments cannot be relied upon to be effective (this includes peat)
- ii) The intended after use, environmental and ecosystem services are dependent on

maintaining (as far as it is possible) the soil functional characteristics such as, porosity and hence drainage and aeration, plant available water capacity, and low resistance to plant root growth. This includes productive agricultural, horticultural and forestry land, but also some natural habitats, and where water storage/infiltration is of importance for risk of flooding. Where the soils are stored prior to replacement some remedial treatment may have to be relied upon.

- ii) The bed/strip soil handling method is not suitable where an archaeological surface needs to be investigated as a whole. Subject to approval by the planning authority the method can be used with care where there is a 'watching brief' by an archaeologist, but may have to be abandoned for another approach where important artefacts are detected. However, trafficking may be restricted to the topsoil surface until the subsoil has been approved for removal and taken away.
- iii) The placement of the stripped soils into stockpiles is likely to result in compression and compaction and may negate this particular benefit of the handling practice.
- iv) As the benefit of the practice lies in the direct placement of the stripped soil it calls for the mineral extraction scheme to be organized to minimize the need for soils storage.

MODEL METHODOLOGY

A.1 Key operational points to minimise the risk of severe soil compaction and wet soil conditions are summarised in Boxes A.1 and A.2.

A.2 The timing of soil handling operations should only take place when the soils are in a 'dry and friable' condition (ie when it breaks and shatters when disturbed rather than smears and deforms) (see **Part One, Supplementary Note 4**). Prior to the start or recommencement of soil handling, they should be tested to confirm they are in suitably dry condition (see Box A.3).

Box A.1 - to minimise compaction:

- The dump trucks should normally only operate on the 'basal'/non-soil layer, and their wheels must not run on to the soil layer/s
- The excavator should normally operate on the topsoil layer
- The adoption of a bed/strip system avoids the need for the trucks to travel on the soil layers
- The machines are to only work when ground conditions enable their efficient operation
- Soils are to be in a 'dry' condition.

Box A.2 - to minimise soil wetness and re-wetting:

- The bed/strip system provides a basis to regulate the exposure of lower soil layers to periods of rain and a means of maintaining soil moisture contents The soil profile within the active strip should be stripped to the basal layer before rainfall occurs and before stripping is suspended
- Measures are required to protect the face of the soil layer from ponding of water and maintain the basal layer in a condition capable of supporting dump trucks
- The area to be stripped is to be protected from in-flow of water, ponding etc. Wet sites should be drained in advance
- The maintenance of a transpiring crop is important, and an appropriate cropping regime should be established for the year of soil stripping
- Before stripping, excess vegetation should be removed; in the case of grassland it should be cut or grazed short and arable crops should have been harvested.

A.3 Soil handling is not to take place during rain, sleet or snow and in these conditions should be prohibited due to unsafe machine operating conditions. Prior to commencing operations, a medium/long term weather forecast should be obtained which gives reasonable confidence of soil handling being completed without significant

Box A.3 - Test for Dry and Friable Soils

Soil tests are to be undertaken in the field. Samples shall be taken from at least five locations on the soil handling area and at each soil horizon to the full depth of the profile to be recovered/replaced. The tests shall include visual examination of the soil and physical assessment of soil consistency.

i) Examination

- If the soil is wet, films of water are visible on the surface of soil particles or aggregates (e.g. clods or peds) and/or when a clod or ped is squeezed in the hand it readily deforms into a cohesive 'ball' means **no soil handling to take place**
- If the sample is moist (i.e. there is a slight dampness when squeezed in the hand) but it does not significantly change colour (darken) on further wetting, and clods break up/crumble readily when squeezed in the hand rather than forming into a ball means **soil handling can take place**
- If the sample is dry, it looks dry and changes colour (darkens) if water is added, and it is brittle means **soil handling can take place**

ii) Consistency**First Test**

Attempt to mould soil sample into a ball by hand:

- Impossible because soil is too dry and hard or too loose and dry means soil handling can take place
- Impossible because the soil is too loose and wet means no soil handling to take place
- Possible - GO TO SECOND TEST

Second Test

Attempt to roll ball into a 3mm diameter thread by hand:

- Impossible because soil crumbles or collapses means **soil handling can take place**
- Possible means **no soil handling to take place**

NB: It is impossible to roll most coarse loamy and sandy soils into a thread even when they are wet. For these soils, the Examination Test alone is to be used.

Box A.4 - Rainfall Criteria:

- In light drizzle soil handling may continue for up to four hours unless the soils are already at/near to their moisture limit
- In light rain soil handling must cease after 15 minutes
- In heavy rain and intense showers, handling shall cease immediately

In all of the above, after rain has ceased, soil tests shall be applied to determine whether handling may re-start, provided that ground conditions are safe to do so.

interruptions from rainfall events. The soil based criteria set out in Box A.4 are to be used to determine whether soil handling should cease or be interrupted with the occurrence of rain.

A.4 All machines must be in a safe and efficient working condition at all times. The machines are to only work when ground conditions enable safe and efficient operation. Otherwise the operation is to be suspended until suitable remedial measures can be put in place.

A.5 The operation should follow the detailed stripping plan set out in the SRMP showing soil units to be stripped, haul routes and the phasing of vehicle movements. The different soil units to be kept separate are to be marked out and information to distinguish types and layers, and ranges of thickness needs to be conveyed to the operational supervisor/operator. The haul routes and soil storage areas must be defined and should be stripped first in a similar manner. Detailed daily records should be kept of operations undertaken, and site and soil conditions.

A.6 Within each soil unit the soil layers above the base/formation layer are to be stripped in sequential strips with the topsoil layer stripped first, followed by the subsoil layers; each layer stripped to its natural thickness without incorporating material from the lower layers. The next strip is not started until the current strip is completely stripped to the basal layer. The system involves the progressive stripping of the soil in strips (**Figure A.1**).

Box A.5

In doing so, compaction by the excavator is largely restricted to the upper layer of soil, which is more easily treated after the soil has been relaid. The degree of topsoil compaction will depend on the machine's ground pressure, its mode of operation and soil wetness. Smaller wide tracked excavators may cause less compaction.

A.7 Unless specified in the SRMP, the excavator is only to work on the topsoil layer and the dump trucks are only to travel on the basal/formation layer (Box A.5).

A.8 Stripping is to be undertaken by the excavator standing on the surface of the topsoil and digging the topsoil to its maximum depth, and it loading into dump trucks. The dump trucks draw alongside the exposed soil profile, standing and travelling only on the basal layer (**Figure A.2**). The type of bucket to be used largely depends on the nature of the soil (Box A.6).

A.9 The initial strip width and axis should be demarcated. The strip width is determined by the length of the excavator boom less the stand-off to safely operate; typically, about 3-4m (Box A.7). Excavators with long booms ('long reach') can be used, but may be more restricted by gradient limitations, and require skilled and experienced operators.

A.10 Topsoil should be recovered to the full width of the strip without mixing with the underlying subsoil (not more than 20% of the lower horizon should be exposed at the layer junction within the strip). The thickness and identification of the horizon junction must be verified before and during stripping. The full thickness of the topsoil horizon should be stripped progressively along the strip before the underlying subsoil horizon(s), if present, is to be started (**Figure A.2**).

Box A.6

For hard/stony soils toothed buckets are needed. Where the mixing of soil layers at their interface is to be minimized, a bucket with a 'blade' is preferable where the soil is 'soft' and free of large stones or stone free. Where there is a watching archaeological brief, the use of bladed buckets will normally be required.

Similarly the choice of bucket type, whether it is a standard 'digging'/bulking or wide ditching type will depend on the soil strength and stoniness.

A.11 The (upper) subsoil in the current strip is then to be stripped and monitored in the same manner. The final 25cm of the subsoil layer should be left as a step to protect the adjacent topsoil layer from local collapses. On completion, the process is to be repeated if there is a lower subsoil, and then any other lower layer to be recovered as a soil material (**Figure A.3**).

Box A.7 - Orientation of the Excavator

Usually the excavator is orientated and operates with its tracks at 90° to the axis of the bed being stripped as this is the most stable position.

Whilst the reach of the boom and hence the width of the bed/strip can be significantly increased and the excavator trafficking over the soil surface decreased by orientating it with the tracks parallel to the soil being stripped, this may affect the stability of the excavator, particularly on a gradient or where soils have a low bearing capacity. Hence its safe deployment needs to be checked before its adoption.

A.12 On completion of the strip, the procedures are repeated sequentially for each subsequent strip until the soil to be stripped is completely removed.

A.13 Where the soils are to be directly replaced (without storage in mounds), the initial strip of the upper horizons will have to be stored temporarily to

release the lowest layer and enable the sequential movement of materials. The stored initial soil material would normally be placed on the lower layer removed from the final strip at the end of the programme or on partially completed profiles if rain interrupted the operation.

A.14 Where the stripping operation is likely to be interrupted by rain, or there is likely to be overnight rain, remove any exposed subsoil down to the basal layer before suspending operations. Make provisions to protect base of current or next strip from ponding/runoff by sumps and grips, and also clean and level the basal layer. At the start of each day ensure there is no ponding in the current strip or operating areas, and the basal layer is to level with no ruts.

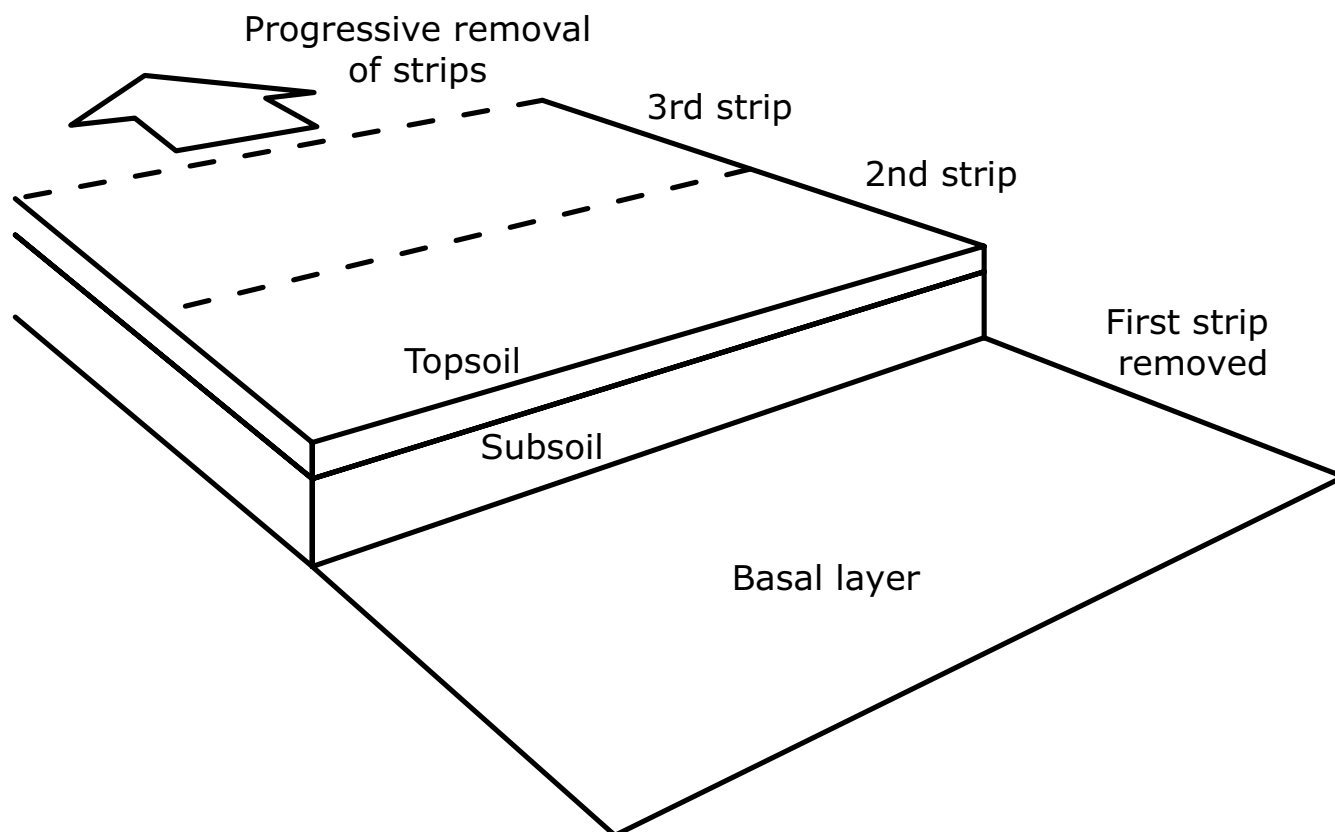

Figure A.1: Soil stripping with excavators and dump trucks: The bed system.

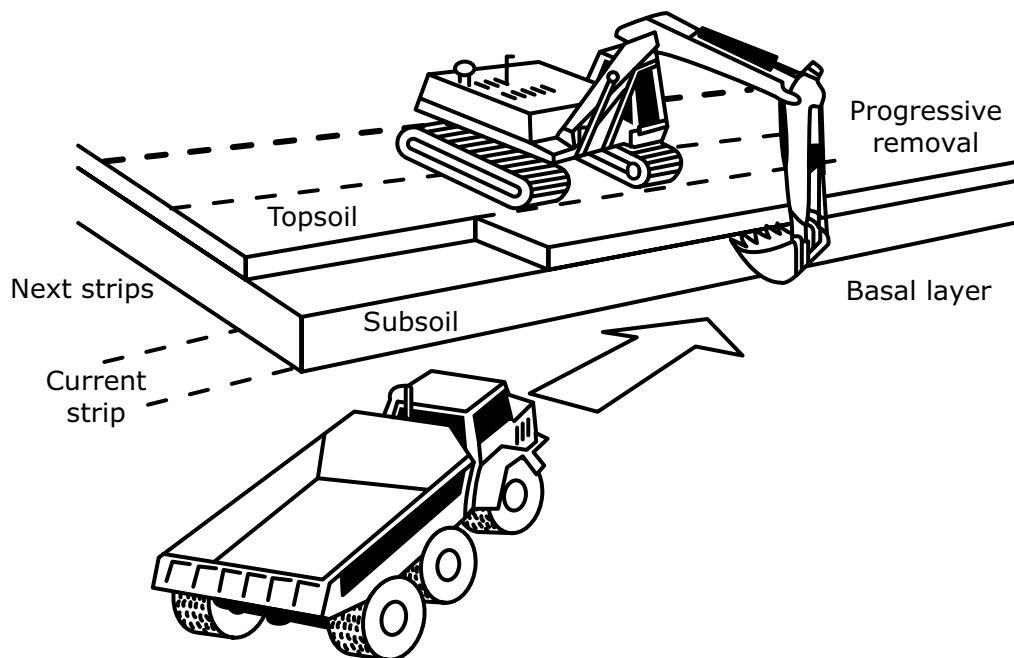

Figure A.2: Stripping with excavators and dump trucks: removal of topsoil from a strip.

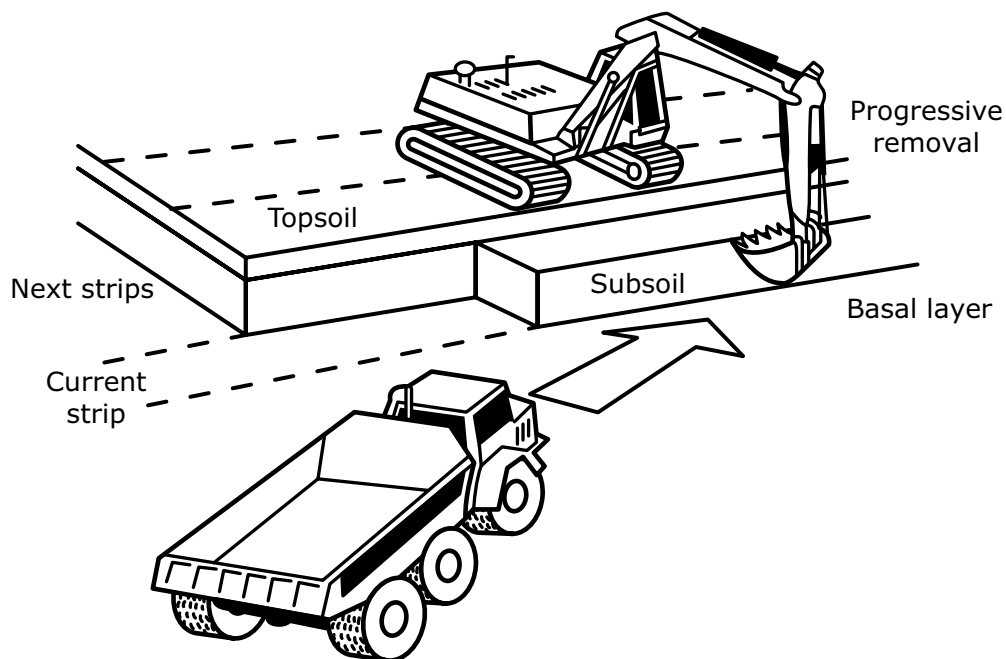

Figure A.3: Stripping with excavators and dump trucks: removal of subsoil from a strip.

GOOD PRACTICE GUIDE FOR HANDLING SOILS

In Mineral Workings

PART TWO: Model Methodology

- Sheet B -

Building Soil Storage Mounds
with Excavators and Dump Trucks

Author: Dr R N Humphries CBiol CSci FRSB FBSSS FIQ
- Blakemere Consultants Ltd & Celtic Energy Ltd

Supporting artwork was provided by R Shelton (H J Banks & Co)
and D Fisher (Blue Room Graphics Ltd).

Preface

The purpose of Sheet B of the guidance is to provide a model method of best practice where excavators and dump trucks are to be used to build soil storage mounds.

The guidance is intended for use by planning officials, statutory consultees, mineral operators and their supporting teams and specialist consultants, and earth-moving contractors, their site supervisors and machine operators.

Successful soil handling schemes are dependent on the soil resources being clearly identified and the conditions in which they are to be handled. This information should be contained in the Soil Resource & Management Plan (SRMP) and communicated to those involved in its implementation.

Key issues to be addressed are:

- i) Avoiding conditions when soils are wet/ plastic during handling
- ii) The minimisation of soil compaction caused by trafficking and soil wetness
- iii) Using appropriate remedial treatments where these are necessary
- iv) Minimising soil loss, and mixing of soil layers or different soil types.

The SRMP should specify the type of earth-moving machinery and soil handling practice, and the soil wetness condition (see Part One of the Guidance) to be deployed to achieve the planned after use, soil functioning, and the environmental and ecosystem services. It is to be communicated in full to all involved and in particular to the supervisors and machine operators by appropriate means; including tool-box talks and site demonstrations. Supervision by trained supervisory staff is essential, as are monitoring and reporting.

The guidance does not specify the size or model of equipment as this is left to the mineral operator and contractor to specify and provide. The machines must be of a kind which are appropriate for the task and the outcomes required, and to be able to carry out the work safely and efficiently.

Should the agreed methodology need to be modified or changed significantly, this should be agreed in advance with the mineral planning authority. The SRMP should include a mechanism whereby unexpected less significant changes can be quickly resolved through consultation between the operator, the planning authority and statutory consultee, and soil specialist.

All persons involved in the handling of soils must comply with all relevant legislation with respect to Health and Safety, in particular the Health and Safety at work Act 1974 and in the case of mineral extraction operations, The Quarries Regulations 1999 and its relevant statutory provisions; in particular those aspects which relate to the construction and removal of tips, mounds and similar structures. These requirements take preference over any suggested practice in this Sheet and the SRMP should have taken these into account.

The users of this guidance are solely responsible for ensuring it complies with all safety legislation and good practice, including the manufacturer's specifications for the safe operation of the specific machines being used, and that all machines are in a good condition and well maintained and are suitable for the task. It is important that those involved in the operation of earth moving machines are competent and have the necessary training and certification.

Introduction

This soil handling method uses back-acting excavators to build the storage mound in combination with dump trucks to transport the soil. Either the excavator sits on the basal layer and casts the tipped soil into a mound or it sits on the tipped soil and pulls it into a mound. The latter is preferred as it is easier to form the mound. In many cases low ground pressure bulldozers are used to grade and trim the finished mound.

Top- and subsoil(s) are to be stored in separate mounds or in clearly defined parts of mounds, in some circumstances where the topsoil can be easily recovered it may be laid over the subsoil.

The space available for storage in mineral workings is often limited and this determines the 'height' of mounds. For topsoil the preference is for 1 to 3m height in order to minimize the impact of storage on biological processes, whereas for subsoils where the biological activity is lower, subject to safe operations, mounds are often raised to heights of 3 to 5m depending on the resilience of the soils to compaction (see Part One & Supplementary Note 3).

In this soil handling option, the mounds are either built as one 'tier' or 'multi-tier' high. In the single tier only the excavator and if used the bulldozer traffic the tipped soil surface and usually the final surface. Whilst, in the multi-tier mounds it is also trafficked by loaded dump trucks.

Advantages & Disadvantages

Storage vs Direct Placement:

The advantages of storage are:

- i) It gives flexibility in the operation of the mineral site
- ii) Flexibility (i.e. weather and ground conditions) for when it is reused.

The disadvantages are:

- i) There is an high risk of compaction of the soil material by stacking in the mound which later cannot be effectively treated
- ii) There may be significant degradation of biological functions with long-term storage.

Single vs Multi-tier Mounds:

The advantage of multi-tier mounds is that they take less space. The disadvantages are:

- i) With multi-tier mounds there is high risk of severe compaction of the soil material layers by repeated trafficking by laden dump trucks in the building of multi-tier mounds which later cannot be effectively treated
- ii) There may be a longer delay in recovery of the soil's biological functions on replacement.

Suitability

Soil storage is less suitable where:

- i) The subsoil(s) are significantly less resilient to compaction (such as silts and sandy clay loams) and when decompaction treatments cannot be relied upon to be effective because of a risk of soil wetness or operational limitations (such as the unavailability of effective decompaction tools) (see **Part One and Supplementary Notes 3 & 4**)
- ii) The intended after use, environmental and ecosystem services are dependent on maintaining functional characteristics such as soil porosity and hence drainage and aeration, plant available water capacity, and low resistance to plant root growth. This usually includes the most productive agricultural, horticultural and forestry land, many types of natural habitats, and where water storage/infiltration is of importance for the risk of flooding
- iii) The bed/strip practice using excavators is used (Sheet A) as the compaction caused can negate its benefit
- iv) Multi-tier mounds are used, particularly where the intended after use, and the environment and ecosystem services are dependent on maintaining functional characteristics such as soil porosity and hence drainage and aeration, plant available water capacity, and low resistance to plant root growth. This usually includes the most productive agricultural and forestry land, many types of natural habitats, and where water storage/infiltration is of importance for the risk of flooding.

MODEL METHODOLOGY

B.1 Key operational points to minimize the risk of severe soil compaction and soil wetness are summarised in Boxes B.1 and B.2.

Box B.1 - To minimize compaction:

- strip in advance the soil to basal layer along haul routes and the operational footprint of the storage mound
- dump trucks are only to stand and travel on the basal layer (unless raising the next level in multi-tier mounds)
- the machines are to only work when ground or soil surface conditions enable their efficient operation
- single-tier mounds should be prioritised over multi-tier mounds as it avoids the need for trafficking on the soil being stored
- raise the soil using only the excavator and maximise the mound height before trucks allowed to access upper surface
- in the raising of multi-tier mounds, trafficking is to be confined to the upper surface of the lower tier. This layer will require decompaction on excavation of the mound.

B.2 The timing of the building of the soil storage mounds will be governed by the weather and soil conditions governing stripping (see **Sheets A, E, F, I**). Unless the soils are required to be kept in a wet state (eg peat), the mounds should be sited on dry ground, not in hollows and should not disrupt local surface drainage (Box B.3). Where necessary mounds should be protected from run-off/ponding by a cut-off ditch which is linked to appropriate water discharge facilities. Where the storage mound is in a hollow due to the removal of surface soils, measures should be undertaken to ensure that water is not able to pond within the storage area.

B.3 All machines must be in a safe and efficient working condition at all times. The machines are to only work when ground conditions enable safe and efficient operation. Otherwise the operation is to be suspended until suitable remedial measures can be

put in place.

Box B.2 - To minimize the wetting of soils:

- soil mounds to be built in dry/draining/drained locations and protect from run-off from adjacent areas
- raise the soil mound to maximum height progressively along the axis of the mound, and shape the mound as it is being built to shed water and seal exposed surfaces whenever stripping is suspended
- measures are required to protect the face of the soil layer from ponding of water and maintain the basal layer in a condition capable of supporting dump trucks.

Box B.3

Where soils such as peat need to be kept in a wet condition this may require storage in (bunded) cells where receiving rainfall cannot drain.

B.4 The operation should follow the detailed stripping/storage plan set out in the SRMP showing soil units to be stripped, haul routes and the phasing of vehicle movements. Different soil units to be kept separate are to be marked out and information to distinguish types and layers, and ranges of thickness needs to be conveyed to the operational supervisor/operator. The haul routes and soil storage areas must be defined and should be stripped first in a similar manner. Detailed daily records should be kept of operations undertaken, and site and soil conditions.

B.5 Adopting the practices outlined in **Sheet A**, where relevant, remove topsoil and subsoil to basal layer from the haul routes, footprint of the storage mound and any other operating area in advance. The soils should be stored in their respective mounds.

B.6 The dump trucks must only travel within the haul route and operational areas. Typically the trucks should enter the storage area, reverse and tip the soil load starting at the furthest point of the

mound from the point of access. The back-acting excavator pulls up the soil into a mound of the required dimensions (Box B.4). The excavator operates by standing on the mound (**Figure B.1**) or the stripped basal layer. The excavator bucket can be used to shape and firm the sides as the mound is progressively formed to promote the shedding of rain.

B.7 The process is repeated with the tipping of soil against the forming mound, and without the dump truck wheels traversing onto previously tipped material. The operation continues progressively along the main axis of the mound.

Box B.4 - Choice of Bucket Type

For hard /stony soils toothed buckets are needed. Where the mixing of soil layers at their interface is to be minimized, a bucket with a 'blade' is preferable where the soil is 'soft' and free of large stones or stone free. Where there is a watching archaeological brief, the use of bladed buckets will normally be required.

Similarly, the choice of bucket type, whether it is a standard 'digging'/bulking or wide ditching type will depend on the soil strength and stoniness.

B.8 Without the trucks rising onto the soil mound, the maximum possible height and width of the mound is related to the boom reach of the excavator (typically about 3-4m). Excavators with long booms ('long reach') can be used, but may be more restricted by gradient limitations, and require skilled and experienced operators.

B.9 To raise the mound higher, as a multi-tier mound, the trucks will have to travel on the upper surface of the mounded soils (first tier). In this case the mound should be raised to its maximum height (**Figure B.2**). A ramp will have to be provided for the trucks to rise onto the surface of the first tier, which should be capable of trafficking safely and without difficulty. The next tier would be formed repeating the process described above.

B.10 If further tiers are required, the process would

be repeated. Any exposed edges/surfaces should be shaped using the excavator bucket on the onset of rain during the day, this should include any exposed incomplete surfaces. All surfaces should be shaped to shed water at the end of the day. The final outer surface should be progressively shaped using the excavator bucket or low ground pressure bulldozer to promote the shedding of rain.

B.11 Work should stop in wet conditions (Box B.5) with measures undertaken to shed water from the soil surfaces and to prevent ponding at the base of the mound and on the basal layer. At the start of each day ensure there is no ponding on the basal layers and operating areas.

Box B.5 - Rainfall Criteria

- In light drizzle soil handling may continue for up to four hours unless the soils are already at/near to their moisture limit
- In light rain soil handling must cease after 15 minutes
- In heavy rain and intense showers, handling shall cease immediately

In all of the above, after rain has ceased, soil tests shall be applied to determine whether handling may re-start, provided that the ground is free from ponding and ground conditions are safe to do so.

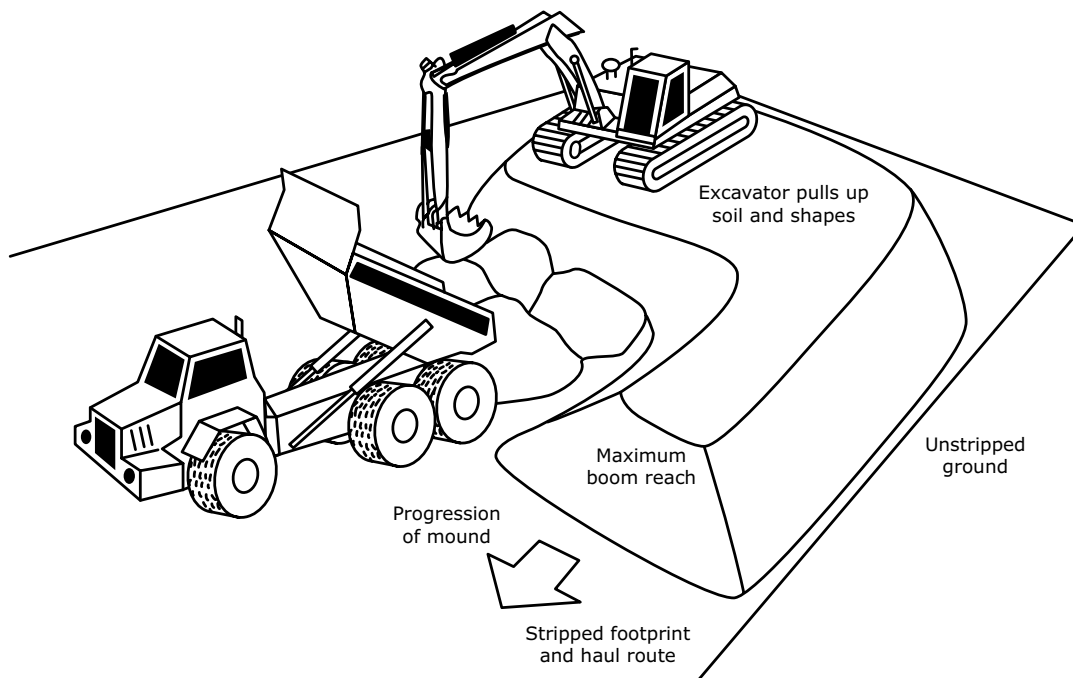

Figure B.1: Soil storage mound construction with excavators and dump trucks: Single tier mound.

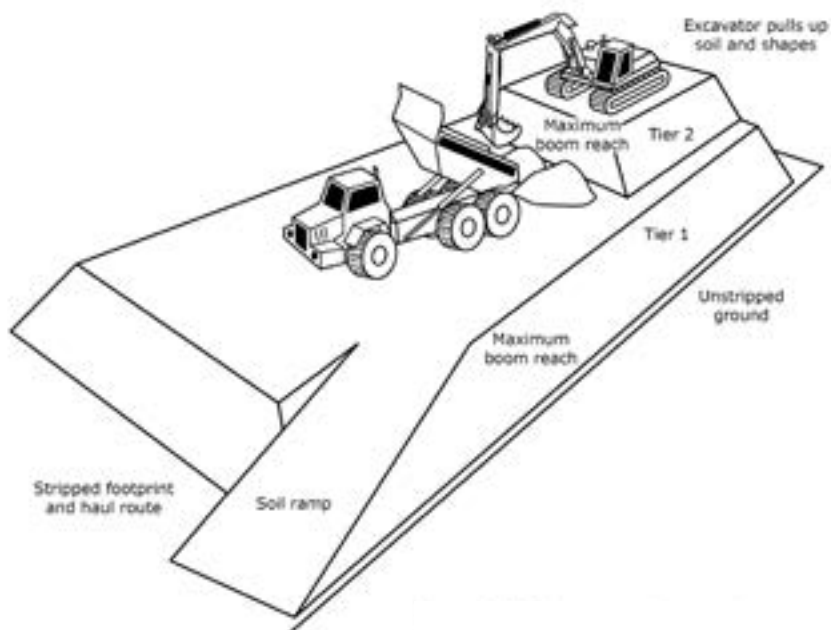

Figure B.2: Soil storage mound construction with excavators and dump trucks: Multi-tier mound.

GOOD PRACTICE GUIDE FOR HANDLING SOILS

In Mineral Workings

PART TWO: Model Methodology

- Sheet C -

Excavation of Soil Storage Mounds
with Excavators and Dump Trucks

Author: Dr R N Humphries CBIol CSci FRSB FBSSS FIQ
- Blakemere Consultants Ltd & Celtic Energy Ltd

Supporting artwork was provided by R Shelton (H J Banks & Co)
and D Fisher (Blue Room Graphics Ltd).

Preface

The purpose of Sheet C of the guidance is to provide a model method of best practice where excavators and dump trucks are to be used to recover soils from storage mounds.

The guidance is intended for use by planning officials, statutory consultees, mineral operators and their supporting teams and specialist consultants, and earth-moving contractors, their site supervisors and machine operators.

Successful soil handling schemes are dependent on the soil resources being clearly identified and the conditions in which they are to be handled. This information should be contained in the Soil Resource & Management Plan (SRMP) and communicated to those involved in its implementation.

Key issues to be addressed are:

- i) Avoiding conditions when soils are wet/ plastic during handling
- ii) The minimisation of soil compaction caused by trafficking and soil wetness
- iii) Using appropriate remedial treatments where these are necessary
- iv) Minimising soil loss, and mixing of soil layers or different soil types.

The SRMP should specify the type of earth-moving machinery and soil handling practice, and the soil wetness condition (see Part One of the Guidance) to be deployed to achieve the planned after use, soil functioning, and the environmental and ecosystem services. It is to be communicated in full to all involved and in particular to the supervisors and machine operators by appropriate means; including tool-box talks and site demonstrations. Supervision by trained supervisory staff is essential, as are monitoring and reporting.

The guidance does not specify the size or model of equipment as this is left to the mineral operator and contractor to specify and provide. The machines must be of a kind which are appropriate for the task and the outcomes required, and to be able to carry out the work safely and efficiently.

Should the agreed methodology need to be modified or changed significantly, this should be agreed in advance with the mineral planning authority. The SRMP should include a mechanism whereby unexpected less significant changes can be quickly resolved through consultation between the operator, the planning authority and statutory consultee, and soil specialist.

All persons involved in the handling of soils must comply with all relevant legislation with respect to Health and Safety, in particular the Health and Safety at work Act 1974 and in the case of mineral extraction operations, The Quarries Regulations 1999 and its relevant statutory provisions; in particular those aspects which relate to the construction and removal of tips, mounds and similar structures. These requirements take preference over any suggested practice in this Sheet and the SRMP should have taken these into account.

The users of this guidance are solely responsible for ensuring it complies with all safety legislation and good practice, including the manufacturer's specifications for the safe operation of the specific machines being used, and that all machines are in a good condition and well maintained and are suitable for the task. It is important that those involved in the operation of earth moving machines are competent and have the necessary training and certification.

Introduction

This soil handling method uses back-acting excavators and sometimes tracked shovels to recover soils from storage mounds in combination with dump trucks to transport the soil to the replacement area. Top- and subsoil may be stored in separate mounds or in clearly defined parts of the same mound, in some circumstances where the topsoil can be easily recovered it may be laid over the subsoil.

In this soil handling option the mounds are either built as single 'tier' or as 'multi-tiers'. In the single tier only the excavator, and if used the bulldozer, traffic the soil surface of the mound. In the multi-tier, the mound is also trafficked by loaded dump trucks.

The suitability, advantages and disadvantages are discussed in Sheet B and are predetermined here by the circumstances and the decision to store the soils. The removal of soils from the store can cause additional compaction. The advantage of this model method is that it should minimize additional severe compaction of the soil as trafficking is minimized. However, where the soil has been stored in multi-tier mounds it is likely to be a need for decompaction treatment of the interface between the tiers where the dump trucks have trafficked during the excavation and loading operation.

MODEL METHODOLOGY

C.1 The timing of excavation of the soil storage mounds will be governed by the weather and soil conditions governing stripping (see Sheet A). Key operational points to minimize the risk of severe soil compaction and soil wetness are summarised in Boxes C.1 and C.2.

C.2 All machines must be in a safe and efficient working condition at all times. The machines are to only work when ground conditions enable safe and efficient operation. Otherwise the operation is to be suspended until suitable remedial measures can be put in place.

C.3 The trucks should enter the storage area and draw alongside the active excavation face. The

Box C.1 - To minimize compaction:

- The dump trucks should only operate on the 'basal'/non-soil layer, and their wheels must not on any circumstances run on to the soil in store
- The excavator should be the only machine to operate on the single tier soil mound
- The machines are to only work when ground conditions enable their efficient operation
- When excavating the multi-tier mounds, to avoid trafficking, a dozer can be used to push the upper tier down to the excavator avoiding the need for trucks trafficking on the mound otherwise excavate tier by tier starting with the uppermost with trafficking confined to the upper surface of the lower tier
- If severe compaction has been caused then measures are required to treat it before it is loaded into the trucks by the excavator 'digging' over the affected layer (see below and Sheet N).

Box C.2 - To minimize soil wetness and rewetting:

- The mound should be shaped to shed water before rainfall occurs whenever removal is suspended
- Measures are required to protect the face of the soil layer from ponding of water and maintain the basal layer in a condition capable of supporting dump trucks.

Box C.3 - Choice of Bucket Type

For hard /stony soils toothed buckets are needed. Where the mixing of soil layers at their interface is to be minimized, a bucket with a 'blade' is preferable where the soil is 'soft' and free of large stones or stone free.

Similarly, the choice of bucket type, whether it is a standard 'digging'/bulking or wide ditching type will depend on the soil strength and stoniness.

back-acting excavator is stand on top of the mound to load trucks (**Figure C.1**) using an appropriate bucket type (Box C.3). The mound is to be dug to the base before moving progressively back along its axis.

C.4 When excavating the multi-tier mounds, where possible, to avoid trafficking a low ground pressure bulldozer can be used to push the upper tier soil down to the excavator. This avoids the need for dump trucks trafficking on the mound. Otherwise excavate tier by tier starting with the uppermost with trafficking confined to the upper surface of the lower tier. Here the excavation should be at the same height of tiers as originally built so that the same surfaces are used for trafficking to build it are again used, so as to minimize further severe compaction (**Figure C.2**). Having removed the upper tier, the trafficked layer(s) must be decompacted. This can be achieved by progressively digging the surface, as described on Sheet N, in advance of loading the next layer. It is essential that the digging is effective and this needs to be checked before soil is loaded. The process is repeated for each soil tier.

C.5 Any exposed edges/surfaces should be shaped on the onset of rain during the day. All surfaces should be shaped to shed water at the end of each day.

C.6 Work should stop in wet conditions (Box C.4) with measures undertaken to prevent ponding at the base of the mound and on the basal layer. At the start of each day ensure there is no ponding on the basal layer and operating areas.

Operational Variation

C.7 Front loading tracked machines may be used to excavate single tier soil mounds provided that they only operate on the basal layer along with the dump trucks (**Figure C.3**).

Box C.4 - Rainfall Criteria:

- In light drizzle soil handling may continue for up to four hours unless the soils are already at/near to their moisture limit
- In light rain soil handling must cease after 15 minutes
- In heavy rain and intense showers, handling shall cease immediately

In all of the above, after rain has ceased, soil tests shall be applied to determine whether handling may re-start, provided that the ground is free from ponding and ground conditions are safe to do so.

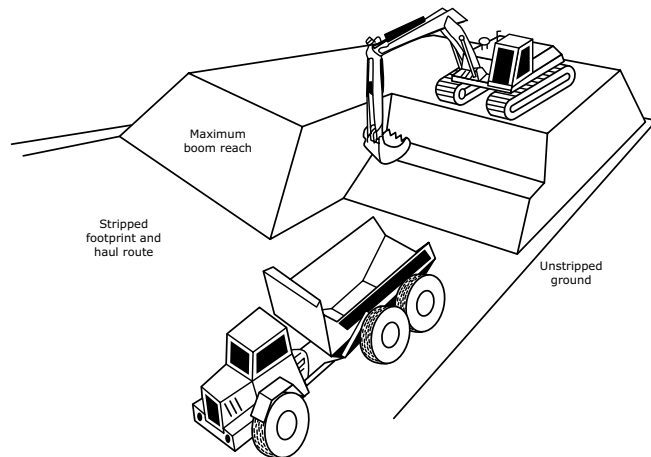

Figure C.1: Excavation of soil storage mounds with excavators and dump trucks: Single tier mounds.

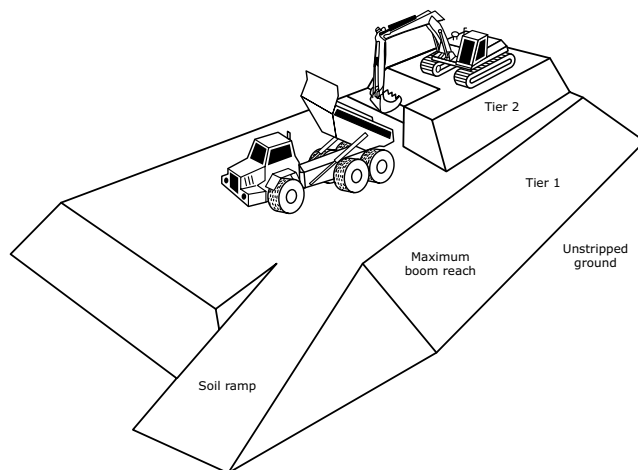

Figure C.2: Excavation of soil storage mounds with excavators and dump trucks: Multi tier mounds.

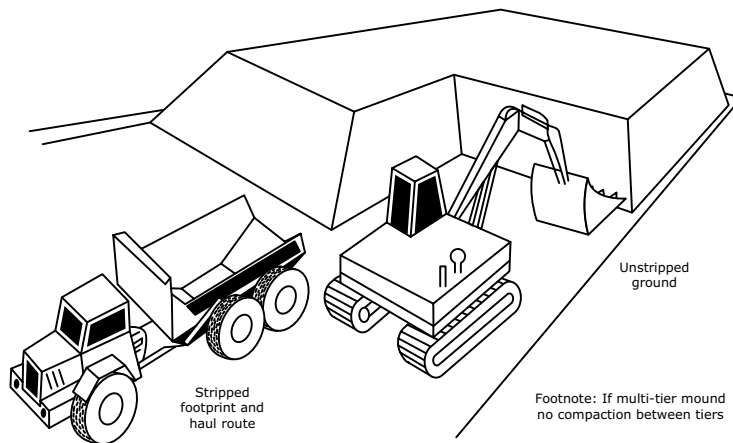

Figure C.3: Excavation of soil storage mounds with front loading shovels and dump trucks: Single and multi tier mounds.

GOOD PRACTICE GUIDE FOR HANDLING SOILS

In Mineral Workings

PART TWO: Model Methodology

- Sheet D -

Soil Replacement with Excavators and Dump Trucks
- Sequential Bed/Strip Practice

Author: Dr R N Humphries CBiol CSci FRSB FBSS FIQ
- Blakemere Consultants Ltd & Celtic Energy Ltd

Supporting artwork was provided by R Shelton (H J Banks & Co)
and D Fisher (Blue Room Graphics Ltd).

Preface

The purpose of Sheet D of the guidance is to provide a model method of best practice where excavators and dump trucks are to be used to replace soil using the sequential 'bed'/strip by strip practice.

The guidance is intended for use by planning officials, statutory consultees, mineral operators and their supporting teams and specialist consultants, and earth-moving contractors, their site supervisors and machine operators.

Successful soil handling schemes are dependent on the soil resources being clearly identified and the conditions in which they are to be handled. This information should be contained in the Soil Resource & Management Plan (SRMP) and communicated to those involved in its implementation.

Key issues to be addressed are:

- i) Avoiding conditions when soils are wet/ plastic during handling
- ii) The minimisation of soil compaction caused by trafficking and soil wetness
- iii) Using appropriate remedial treatments where these are necessary
- iv) Minimising soil loss, and mixing of soil layers or different soil types

The SRMP should specify the type of earth-moving machinery and soil handling practice, and the soil wetness condition (see Part One of the Guidance) to be deployed to achieve the planned after use, soil functioning, and the environmental and ecosystem services. It is to be communicated in full to all involved and in particular to the supervisors and machine operators by appropriate means; including tool-box talks and site demonstrations. Supervision by trained supervisory staff is essential, as are monitoring and reporting.

The guidance does not specify the size or model of equipment as this is left to the mineral operator and contractor to specify and provide. The machines must be of a kind which are appropriate for the task and the outcomes required, and to be able to carry out the work safely and efficiently.

Should the agreed methodology need to be modified or changed significantly, this should be agreed in advance with the mineral planning authority. The SRMP should include a mechanism whereby unexpected less significant changes can be quickly resolved through consultation between the operator, the planning authority and statutory consultee, and soil specialist.

All persons involved in the handling of soils must comply with all relevant legislation with respect to Health and Safety, in particular the Health and Safety at work Act 1974 and in the case of mineral extraction operations The Quarries Regulations 1999 and its relevant statutory provisions; in particular those aspects which relate to the construction and removal of tips, mounds and similar structures. These requirements take preference over any suggested practice in this Sheet and the SRMP should have taken these into account.

The users of this guidance are solely responsible for ensuring it complies with all safety legislation and good practice, including the manufacturer's specifications for the safe operation of the specific machines being used, and that all machines are in a good condition and well maintained and are suitable for the task. It is important that those involved in the operation of earth moving machines are competent and have the necessary training and certification.

Introduction

In this soil handling option, back-acting excavators are used to replace the soil resources tipped from dump trucks at the area being restored.

The replacement practice involves the sequential building up of the individual layers of soil identified in the Soil Resource & Management Plan (SRMP) as vertical slices through the soil profile and advancing as successive strips. Hence, the practice is often referred to as the 'Strip' or 'Bed' method.

The lower layer (subsoil) is placed first within the safe and efficient operational reach of the excavator boom which defines the width of each strip. For each subsequent soil layer, the process is repeated until the top layer (usually topsoil) is placed. When the soil resource/profile sequence within the strip is completely replaced, the process is repeated on the next strip to be replaced with soil and until the whole receiving area is completed. The following guidance can also be adopted where only a single soil horizon is to be replaced.

Unlike the stripping and storage practices, the replacement of soils is usually in concert with other work to remediate soil conditions such as compaction (**Sheets N & O**) and removal of stones/non-soil debris (**Sheets L & M**) to facilitate the intended after use, soil functions, and environmental and ecosystem service provisions. These actions have their own practices which need to be integrated into this model methodology of soil handling. The need for these will have been specified in the SRMP and/or in soil replacement conditions attached to the planning consent, or as determined by the soil specialist during the soil stripping/storage/replacement operations.

Advantages & Disadvantages

The advantages of this machinery combination and handling practice are:

- i) Provided the soils are not put into storage mounds, it is the most likely to result in soil profiles with the least compacted soils, which may not require remedial treatment or only minimal of action, as trafficking on the relayed soils is avoided
- ii) It can be easier to create localised changes

- iii) in soil types and variation in horizon depth It is suited both to the replacement of deep and uniform soils (including peat) as well as thin and 'patterned' soil layers
- iv) It is more flexible and quicker in responding to stoppages and restarts due to wet weather
- v) There is a greater certainty that a transpiring vegetation cover can be established during the soil replacement programme

The disadvantages are:

- i) That it requires greater supervision, skill and discipline in its deployment, and is best suited to experienced operators
- ii) Without good control and regular monitoring of soil layer depths, use of profile boards or machine fitted GPS it can be harder to gauge the rate of use of soil resource
- iii) There is a risk of some soil 'loss' and mixing of soil horizons at the exposed edges of multi-layered soils as the profile is built up
- iv) The bed system involving sequential remedial works may take longer to complete than other practices and machinery options
- v) Steep gradient/complex topographies may limit the safe and practical deployment of this handling practice

Suitability

The excavator-dump truck combination with the bed/strip handling practice methodology is considered 'best practice' by Natural England and the Welsh Government for agricultural soils and preferable for all soils. In particular, it is the most suitable of any of the methods available where:

- i) The soil is prone to compaction and where decompaction treatments cannot be relied upon to be effective
- ii) The intended after use, environmental and ecosystem services are dependent on soils maintaining their functional characteristics such as, porosity and hence drainage and aeration, plant available water capacity, and low resistance to plant root growth. This includes productive agricultural, horticultural and forestry land, many types of natural habitats, and where water storage/infiltration is of importance for the risk of flooding. Where the soils are stored prior

- to replacement some remedial treatment may have to be relied upon
- iii) As the bed/strip method offers the most flexibility in respect of short soil drying periods and likely wet weather, and can be less prone to delays and stoppages, it is particularly suited the wetter geographical locations
- iv) The full benefit of the practice for soils lies in their direct placement, this requires the mineral extraction scheme to be organized to minimize the need for soils storage.

MODEL METHODOLOGY

Basic Soil Replacement Operation

D.1 The following is the basic model methodology using excavators and dump trucks and the bed/strip practice. It is presented here, firstly without any remedial interventions to give clarity of the methodology. Further on the methodology is repeated to demonstrate how the interventions can be integrated in to the soil replacement process.

D.2 Key operational points to minimise the risk of severe soil compaction and soil wetness are summarised in Boxes D.1 and D.2.

D.3 The timing of soil handling operations in England and Wales is set out in **Part One, Supplementary Note 4**. For directly placed soils this will use the in situ soil wetness protocol for soil stripping operations to determine the timing for soil replacement (Box D.3). For soil that has been stored, the relaying operation should be governed by the weather (rainfall) criteria set out in Box D.4. Here, the operation will generally need to be completed no later than the end of September unless the establishment of a satisfactory vegetation cover can be assured.

D.4 Soil handling is not to take place during rain, sleet or snow and in these conditions should be prohibited if unsafe for machine operations. Prior to commencing operations, a medium/long term weather forecast should be obtained which gives reasonable confidence of soil handling being completed without significant interruptions from rainfall events. The soil based criteria set out in

Box D.1 - To minimise compaction:

- The dump trucks should only operate on the 'basal'/non-soil layer and not run on the replaced soil layer(s)
- The excavator must only operate on the basal layer
- The machines are to only work when ground conditions enable their efficient operation
- If compaction has been caused, then measures are required to treat it (see **Sheets N & O**).

Box D.2 - To minimise soil wetness and re-wetting:

- The bed/strip system provides a basis to regulate the exposure of lower soil layers to periods of rain and a means of maintaining soil moisture contents. The soil profile within the active strip should be completed including the topsoil layer before rainfall occurs and before replacement is suspended
- Measures are required to protect the face of the soil layer from ponding of water and maintain the basal layer in a condition capable of supporting dump trucks
- The area to be restored is to be protected from in-flow of water, ponding etc. Wet sites must be drained in advance. Before the operation starts the basal layer should be to level and clean.

Box D.4 are to be used to determine whether soil handling should cease or be interrupted with the occurrence of rain.

D.5 All machines must be in a safe and efficient working condition at all times. The machines are to only work when ground conditions enable their efficient operation. The work should only be carried out when the basal layer supports the machinery without ruts or is capable of repair/maintenance. Otherwise the operation is to be suspended until suitable remedial measures can be put in place.

D.6 The operation should follow the detailed SRMP replacement plan showing the soil units to be replaced, haul routes and the phasing of vehicle movements. The soil units should be defined on the site with information to distinguish types and layers,

Box D.3 - Test for Dry and Friable Soils

Soil tests are to be undertaken in the field. Samples shall be taken from at least five locations on the soil handling area and at each soil horizon to the full depth of the profile to be recovered/replaced. The tests shall include visual examination of the soil and physical assessment of soil consistency.

i) Examination

- If the soil is wet, films of water are visible on the surface of soil particles or aggregates (e.g. clods or peds) and/or when a clod or ped is squeezed in the hand it readily deforms into a cohesive 'ball' means **no soil handling to take place**
- If the sample is moist (i.e. there is a slight dampness when squeezed in the hand) but it does not significantly change colour (darken) on further wetting, and clods break up/crumble readily when squeezed in the hand rather than forming into a ball means **soil handling can take place**
- If the sample is dry, it looks dry and changes colour (darkens) if water is added, and it is brittle means **soil handling can take place**

ii) Consistency**First Test**

Attempt to mould soil sample into a ball by hand:

- Impossible because soil is too dry and hard or too loose and dry means soil handling can take place
- Impossible because the soil is too loose and wet means no soil handling to take place
- Possible - GO TO SECOND TEST

Second Test

Attempt to roll ball into a 3mm diameter thread by hand:

- Impossible because soil crumbles or collapses means **soil handling can take place**
- Possible means **no soil handling to take place**

NB: It is impossible to roll most coarse loamy and sandy soils into a thread even when they are wet. For these soils, the Examination Test alone is to be used.

Box D.4 - Rainfall Criteria:

- In light drizzle soil handling may continue for up to four hours unless the soils are already at/near to their moisture limit
- In light rain soil handling must cease after 15 minutes
- In heavy rain and intense showers, handling shall cease immediately

In all of the above, after rain has ceased, soil tests shall be applied to determine whether handling may re-start, provided that the ground is free from ponding and ground conditions are safe to do so.

and thickness and conveyed to the operational supervisor/operator. Different soil units to be kept separate are to be marked out and information to distinguish types and layers, and ranges of thickness needs to be conveyed to the operational supervisor/operator. Detailed daily records should be kept of operations undertaken and site and soil conditions.

D.7 The excavator and dump trucks are only to stand, work and travel on the basal/formation layer.

D.8 The soil layers above the base/formation layer are to be replaced in sequential strips with the sub-soil layer(s) replaced first, followed by the topsoil layer, each layer being replaced to the specified thickness. The next strip is not to be started until the profile in the current strip is completed. This is often referred to as the 'bed' or 'strip' system which involves the progressive sequential laying of the soil in strips across the area to be restored (**Figure D.1**).

D.9 The initial strip width and axis is to be demarcated. The strip width is determined by excavator boom length less the stand-off to operate; typically, about 3-4m (Box D.5). Excavators with long booms ('long reach') can be used, but may be more restricted by gradient limitations, and require skilled and experienced operators.

D.10 The preferred type of bucket to place the soils is usually a digging/bulking bucket with an attached blade or a wide ditching bucket, but a toothed

bucket can be used.

D.11 Profile boards should be used to control soil horizon thickness in each strip and overall levels achieved verified using soil pits. Allowances (i.e. a bulking factor) should be made for any settlement that may take place of the replaced loose soil.

Box D.5 - Orientation of the Excavator

Usually, the excavator is orientated and operates with its tracks at 90° to the axis of the bed being stripped as this is the most stable position. Whilst the reach of the boom and hence the width of the bed/strip can be significantly increased by orientating it with the tracks parallel to edge of the soil being spread, this may affect the stability of the excavator, particularly on a gradient or where the basal layer has a low bearing capacity. Hence, its safe deployment needs to be checked before its adoption.

D.12 The dump trucks reverse up to edge of the current strip and tip the lowest layer (subsoil) soil, without the wheels riding onto the strip (**Figure D.1**). The dump truck should not drive away until all the soil is deposited within the strip without spillage over the basal layer; this may require assistance from the excavator to 'dig away' some of the tipped soil (**Figure D.2**). The excavator is to spread the tipped soil to full thickness by digging, and using the pushing and pulling action of bucket.

D.13 Each load of soil should be spread following tipping before another is tipped. Should the spread soil comprise of large blocks (>300mm), normally these should be broken down by using the excavator bucket into smaller pieces before the next load is spread. The process is repeated until the strip is completely covered with the required depth of the soil layer (**Figure D.3**).

D.14 On completion of the lowest (subsoil) layer, repeat the process spreading the next layer (subsoil/topsoil) (**Figure D.4**). Tip the soil by reversing to the outer edge of strip/soil previously laid, but without the truck wheels riding onto the already placed layer (see Box D.6 for deep soil profiles). The soil is to be

spread by the excavator to full thickness by digging, and using the pushing and pulling action of bucket described above. Repeat the process progressively along the strip. Profile boards should be used to control the soil thickness in the strip and overall levels.

D.15 Where the profile is made up of further soil layers (subsoil/topsoil) the above process should be repeated on completion of the strip.

BOX D.6 - Soil Profiles Greater Than 1m Thickness

When the replaced soil profiles reach about 1m in height from the basal layer it may not be possible to discharge the load from smaller dump trucks directly onto the previously placed lower layers because of the height of the dump truck body. The preferred solution is to tip the soil against the partially completed profile as heaps without the dump trucks rising onto or reversing into the placed material. The soil material is then lifted by the excavator onto the profile. It is considered preferable to accept some limited soil losses rather than to contaminate the topsoil with overburden. The loss of top-soil is minimised if the basal/ formation layer is kept to level and clean.

D.16 On completion of topsoil layer, the processes outlined above should be repeated for the next strips until the area to be restored is completed. Before the operation starts the basal layer should be to level and cleared of any residual soil.

D.17 At the end of each day the current strip must be completed if rain is forecast. If during a day it is evident that a full strip cannot be completed, then complete the part of a strip that has been started.

D.18 At the end of each day, or during the day if interrupted by rain, make provisions to protect base of restored strip from ponding/runoff by sumps and grips, and also clean and level the basal layer. At the start of each day ensure there is no ponding in the current strip or operating areas, and the basal layer is to level with no ruts.

Method with Integration of Remedial Actions

D.19 Usually there should be less of a need for remedial treatment during the replacement operation with this machinery combination and handling practice (unless the soils were compacted during stripping or storage). Where compaction occurs, treatment will need to be integrated into the replacement process as will the need for the removal of stones or non-soil debris. Both decompaction and the removal of materials are covered in **Sheets L to O**. Where required, the early installation of under drainage can either be integrated sequentially during the replacement of the soils or later during the aftercare period.

D.20 The placement of the stripped soils in storage is likely to result in compaction and negate this particular benefit of the handling practice. Box D.7 sets out some of the remedial options/combinations to facilitate decompaction, and where necessary, the removal of stones and non-soil debris for a final profile comprising a basal layer, subsoil and topsoil layers. Except for Option 3, these actions need to be undertaken sequentially as each soil strip is placed.

D.21 The following is the model methodology integrating the remedial interventions within the bed/strip handling practice.

D.22 The key operational points to minimise the risk of severe soil compaction and soil wetness are summarised in the above Boxes 1 and 2.

D.23 Prior to commencing operations a weather forecast should be obtained which gives reasonable confidence of soil replacement proceeding without interruptions from rainfall events (Box D.4).

D.24 If significant rainfall occurs during operations, the replacement must be suspended, and where the soil profile has been started it should be replaced to topsoil level. Replacement should not restart unless the weather forecast is expected to be dry for at least a full day and the soils are in a dry condition (Box D.3).

D.25 The operation should follow the detailed replacement plan in the SRMP showing the soil units to be replaced, haul routes and the phasing

Box D.7 - Integration of Decompaction & Stone/Debris Removal

Option 1: is where the basal layer needs to be treated but is left until the subsoil is placed when both are decompacted together, followed by the decompaction of the topsoil and subsoil layers together (and basal layer) using tines that are long enough. This option is not suited to digging where the soil horizons would be mixed.

Option 2: is where each layer is treated separately by either tines or digging.

Option 3: is where the basal layer is treated or left untreated, followed by the placement of the subsoil and topsoil layers, which are to be decompacted by the use of tines. In the case of deep horizons this option can be limited by the capability of the machinery, the tines or bucket used. This option is not suited to digging where the soil horizons would be mixed.

of vehicle movements. The soil units should be defined on the site with information to distinguish types and layers, and thickness and conveyed to the operational supervisor/operator. Different soil units to be kept separate are to be marked out and information to distinguish types and layers, and ranges of thickness needs to be conveyed to the operational supervisor/operator. Detailed daily records should be kept of operations undertaken and site and soil conditions (including the removal of stones and other non-soil debris that needs to be removed), and the results of the effectiveness of the work undertaken, and any need for additional remedial treatments.

D.26 The excavator and dump trucks are only to stand, work and travel on the basal/formation layer. Only where the remedial work involves the use of a bulldozer does machinery have to traffic the soil surface being treated, as the excavators work from the basal layer.

D.27 The soil layers above the base/formation layer are to be replaced in sequential strips with the subsoil layer(s) replaced first, followed by the topsoil

layer; each layer being replaced to the specified thickness. The next strip is not to be started until the profile in the current strip is completed. This is often referred to as the 'bed' or 'strip' system which involves the progressive sequential laying of the soil in strips across the area to be restored (**Figure D.1**).

D.28 The initial strip width and axis is to be demarcated. Strip width is determined by excavator boom length less the stand-off to operate; typically, about 3-4m (see Box D.5).

D.29 The preferred type of bucket to place the soils is usually a digging/bulking bucket with an attached blade or a wide ditching bucket. However, where a bucket is being used to decompact soils, it should be a 'digging' type and have teeth or a stone-rake type with multiple tines is to be used.

D.30 Where there is a requirement to treat compaction and/or remove stones/damaging materials in the basal layer, these need to be carried out along the demarcated strip prior to the first layer of soils being laid.

D.31 Decomposition of the basal layer can be by digging with the excavator bucket or by bulldozer drawn tines (**Sheets N & O**). Stone removal may require prior ripping/digging to release them from the basal material, followed by the excavator using a stone-rake bucket (the stone to be loaded on a dump truck and removed (**Sheet L**).

D.32 Profile boards should be used to control soil horizon thickness in each strip and overall levels achieved verified using soil pits to verify. Allowances (i.e. a bulking factor) should be made for any settlement that may take place of the replaced loose soil.

D.33 On completion, the loaded dump trucks reverse up to edge of the current strip and tip the lowest layer subsoil without the wheels riding onto the strip (**Figure D.1**). The dump truck should not drive away until all the soil is deposited within the strip without spillage over the basal layer; this may require assistance from the excavator to 'dig away' some of the tipped soil (**Figure D.2**). The excavator is to spread the tipped soil to full thickness by

digging, and using the pushing and pulling action of bucket.

D.34 Each load of soil should be spread following tipping before another is tipped. Should the spread soil comprise of large blocks (>300mm), normally these should be broken down by using the excavator bucket to break the blocks into smaller pieces before the next load is spread. The process is repeated from left to right until the strip is completely covered with the required depth of the soil layer (**Figure D.3**).

D.35 Where there is a requirement to treat compaction and/or remove stones/damaging materials in the subsoil layer, these need to be carried out along the demarcated strip prior to the next overlying layer of soils being laid. Decomposition can be by digging with the excavator bucket or by bulldozer drawn tines (**Sheets N & O**). Stone removal may require prior ripping/digging to release them from the soil (particularly if it is wet), followed by the excavator using a stone-rake bucket (to be loaded on a dump truck and removed (**Sheet L**).

D.36 On completion of the lowest (subsoil) layer, repeat the process spreading the next layer (topsoil or upper subsoil) (**Figure D.4**). Where the profile is made up of further soil layers (subsoil/topsoil) the process outlined above should be repeated on completion of the strip. Tip the soil by reversing to the outer edge of strip/soil previously laid, but without the truck wheels riding onto the already placed layer (see Box D.6). The topsoil is to be spread by the excavator to full thickness by digging, and using the pushing and pulling action of bucket described above. Repeat the process progressively along the strip. Profile boards should be used and soil pits to verify soil thickness and overall levels in each strip.

D.37 Where there is a requirement to treat compaction in the topsoil layer within each strip as it is completed (see Box D.8), this can be by digging with the excavator bucket or by bulldozer drawn tines (**Sheets N & O**). If required, stone removal may require prior ripping/digging to release them from the soil clods, followed by the excavator using a stone-rake bucket (the stone to be loaded on a dump truck

and removed) (**Sheet L**).

D.38 On completion of the topsoil layer the processes outlined above should be repeated for the next strips until the whole area to be restored is completed. Before the operation starts the basal layer should be to level and clean.

D.39 At the end of each day the current strip must be completed if rain is forecast. If during a day it is

Box D.8

It is important that the decompaction and any stone/debris is removed from the topsoil layer as each strip is completed. Leaving it until the entire area is soiled will mean that the equipment, and in particular where the dump trucks collecting stones, have to traffic the soil surface resulting in compaction of the topsoil and the underlying subsoil.

Decompaction might be undertaken from the topsoil surface once the placing of the soils is completed (see **Sheet O**). However, this only advisable where it is certain that it will be effective and no other earth-moving machinery is to traffic the replaced soil and that soil wetness and weather conditions are suitable (see **Part One, Supplementary Notes 3 & 4**).

evident that a full strip cannot be completed, then complete the part of a strip that has been started.

D.40 At the end of each day, or during the day if interrupted by rain, make provisions to protect base of restored strip from ponding/runoff by sumps and grips, and also clean and level the basal layer. At the start of each day ensure there is no ponding in the current strip or operating areas, and the basal layer is to level with no ruts.

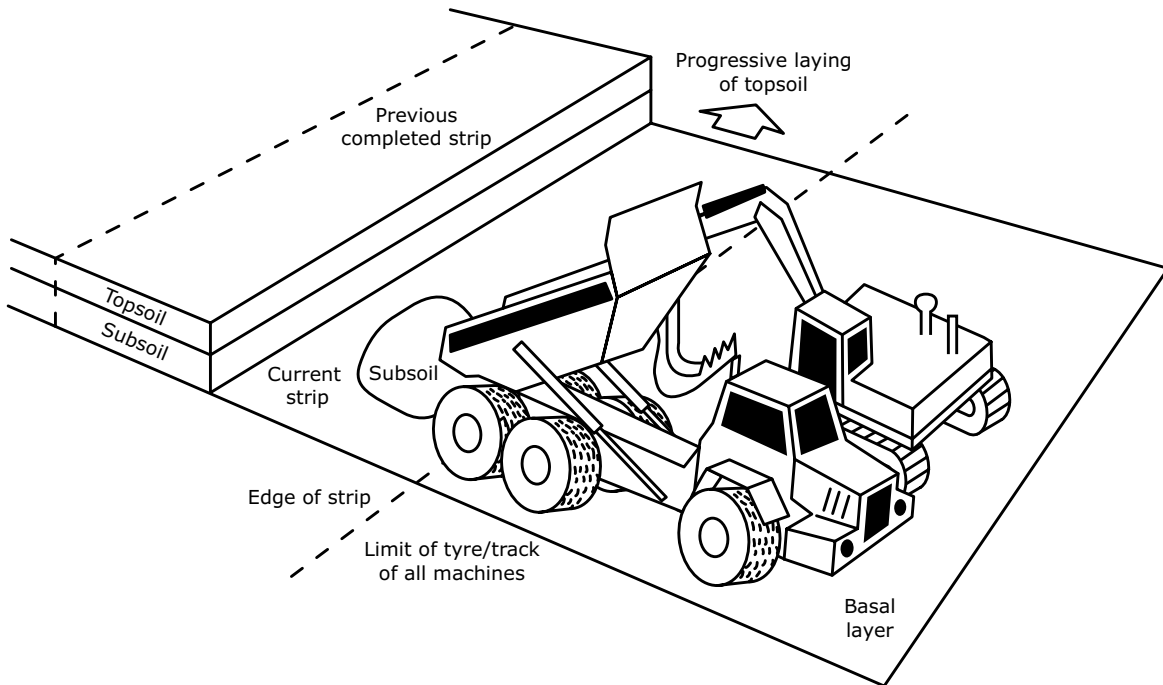

Figure D.1: Soil replacement with excavators and dump trucks: Subsoil layer.

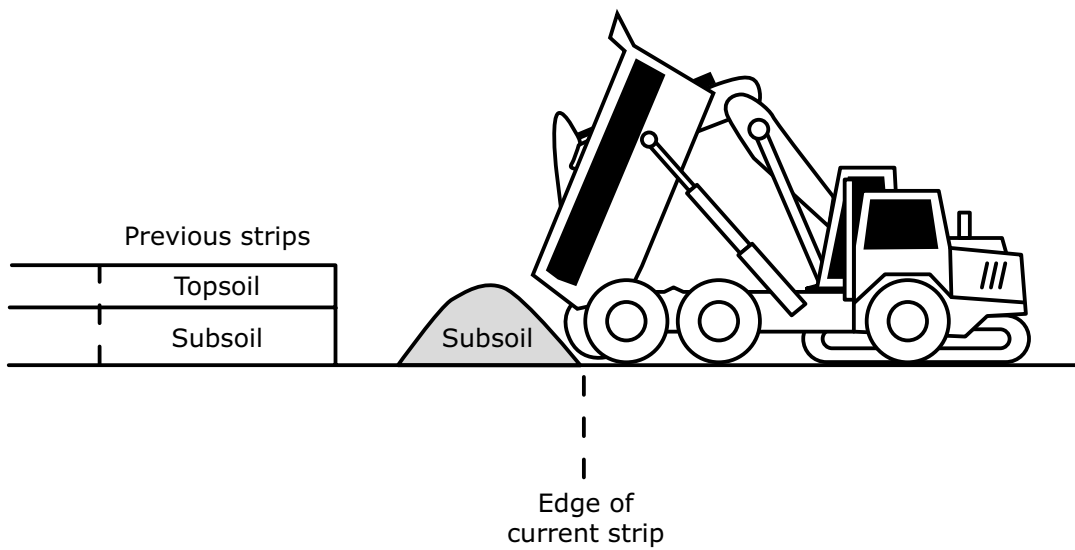

Figure D.2a: Soil replacement with excavators - dump trucks: Subsoil layer.

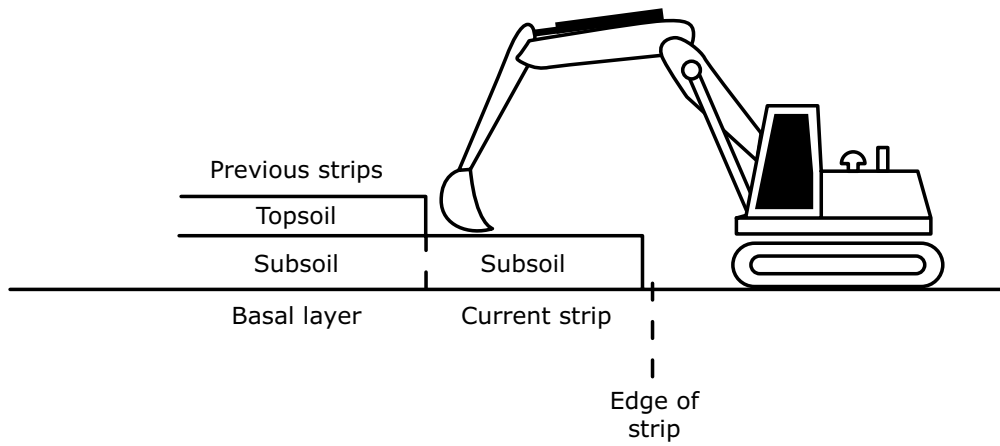

Figure D.2b: Soil replacement with excavators - dump trucks: Subsoil layer.

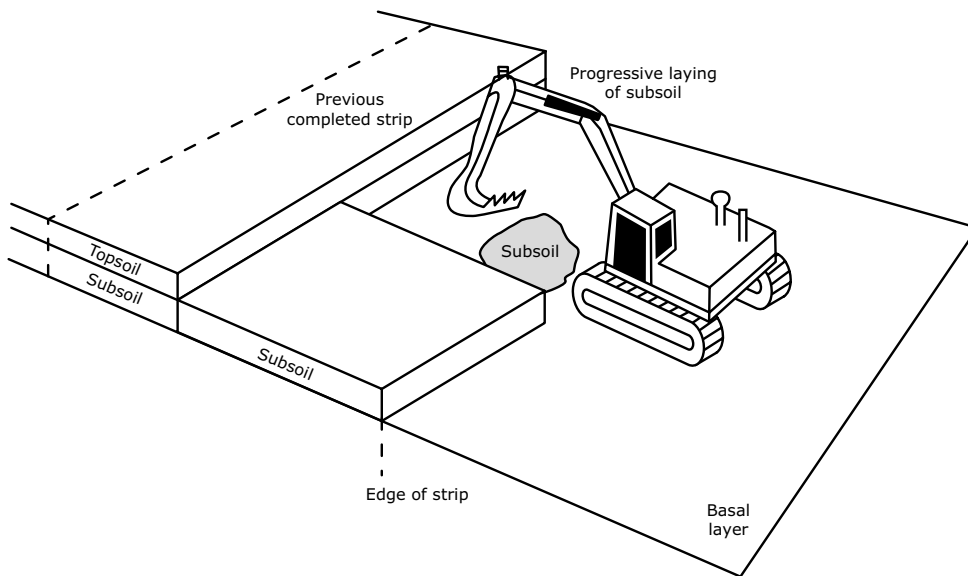

Figure D.3: Soil replacement with excavators and dump trucks: Subsoil progressively laid.

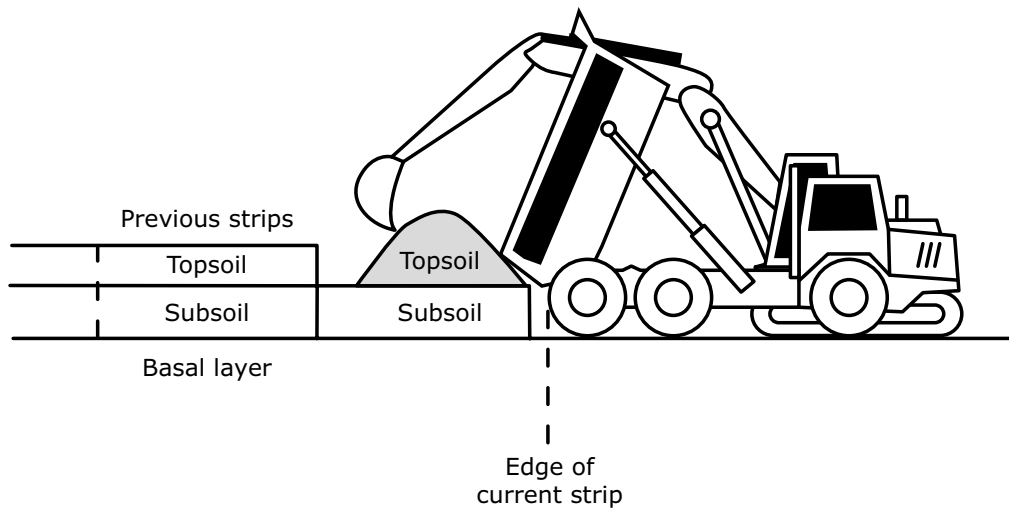

Figure D.4a: Soil replacement with excavators - dump trucks: Topsoil layer.

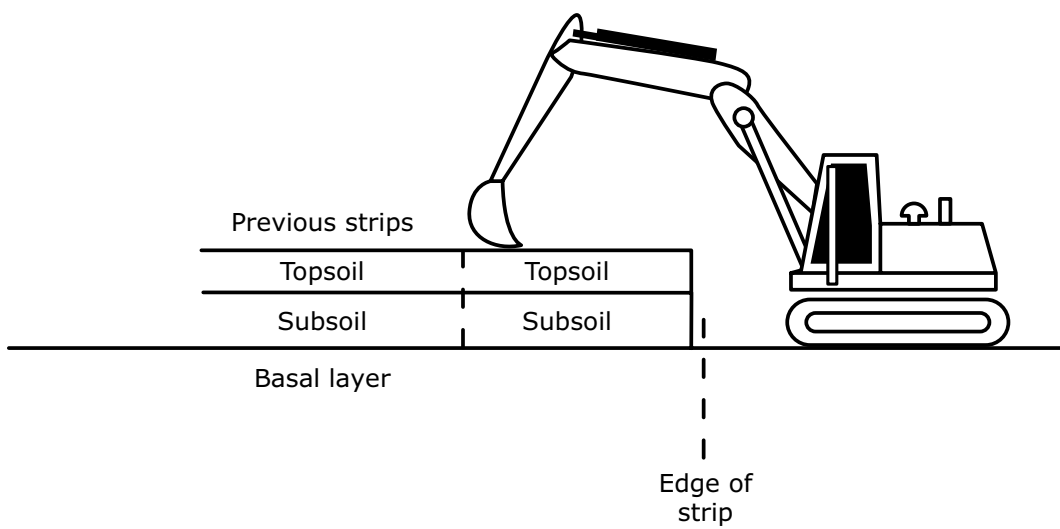

Figure D.4b: Soil replacement with excavators - dump trucks: Topsoil layer.

GOOD PRACTICE GUIDE FOR HANDLING SOILS

In Mineral Workings

PART TWO: Model Methodology

- Sheet E -

Soil Stripping with Excavators and Dump Trucks
- Windrow Practice

Author: Dr R N Humphries CBiol CSci FRSB FBSSS FIQ
- Blakemere Consultants Ltd & Celtic Energy Ltd

Supporting artwork was provided by R Shelton (H J Banks & Co)
and D Fisher (Blue Room Graphics Ltd).

Preface

The purpose of Sheet E of the guidance is to provide a model method of best practice where excavators and dump trucks are to be used to strip soil using the windrow practice.

The guidance is intended for use by planning officials, statutory consultees, mineral operators and their supporting teams and specialist consultants, and earth-moving contractors, their site supervisors and machine operators.

Successful soil handling schemes are dependent on the soil resources being clearly identified and the conditions in which they are to be handled. This information should be contained in the Soil Resource & Management Plan (SRMP) and communicated to those involved in its implementation.

Key issues to be addressed are:

- i) Avoiding conditions when soils are wet/plastic during handling
- ii) The minimisation of soil compaction caused by trafficking and soil wetness
- iii) Using appropriate remedial treatments where these are necessary
- iv) Minimising soil loss, and mixing of soil layers or different soil types.

The SRMP should specify the type of earth-moving machinery and soil handling practice, and the soil wetness condition (see Part One of the Guidance) to be deployed to achieve the planned after use, soil functioning, and the environmental and ecosystem services. It is to be communicated in full to all involved and in particular to the supervisors and machine operators by appropriate means; including tool-box talks and site demonstrations. Supervision by trained supervisory staff is essential, as are monitoring and reporting.

The guidance does not specify the size or model of equipment as this is left to the mineral operator and contractor to specify and provide. The machines must be of a kind which are appropriate for the task and the outcomes required, and to be able to carry out the work safely and efficiently.

Should the agreed methodology need to be modified or changed significantly, this should be agreed in advance with the mineral planning authority. The SRMP should include a mechanism whereby unexpected less significant changes can be quickly resolved through consultation between the operator, the planning authority and statutory consultee, and soil specialist.

All persons involved in the handling of soils must comply with all relevant legislation with respect to Health and Safety, in particular the Health and Safety at work Act 1974 and in the case of mineral extraction operations, The Quarries Regulations 1999 and its relevant statutory provisions; in particular those aspects which relate to the construction and removal of tips, mounds and similar structures. These requirements take preference over any suggested practice in this Sheet and the SRMP should have taken these into account.

The users of this guidance are solely responsible for ensuring it complies with all safety legislation and good practice, including the manufacturer's specifications for the safe operation of the specific machines being used, and that all machines are in a good condition and well maintained and are suitable for the task. It is important that those involved in the operation of earth moving machines are competent and have the necessary training and certification.

Introduction

In this soil handling option, back-acting excavators are used to lift the soil resources gathered in ‘windrows’ and load them into dump trucks for the direct transport to an area being restored or to storage until needed.

The windrow stripping practice, sometimes referred to as the ‘peninsular’ method, involves the sequential separation and removal of the individual layers of soil identified in the Soil Resource & Management Plan (SRMP). The area to be stripped is divided into spaced parallel strips (windrows) where the soil between them is pulled from each side onto the strip acting as temporary repositories. The safe and efficient operational reach of the excavator boom defines the width between the windrows. The topsoil on the retreating surcharged windrows is then loaded systematically into the dump trucks by the excavator retreating towards the loading point on the haul route. On completing the removal of the topsoil, the exposed subsoil layer(s) is then recovered by the same procedure. The practice of stripping all the top-soil layer before starting the lower soil layers should be avoided as it increases the risk of rainfall events causing longer stoppages. The following guidance can also be adopted where only a single surface soil horizon is to be stripped.

Advantages & Disadvantages

The advantages of this machinery combination and handling practice are that:

- i) It is a relatively simple operation to undertake and can be quicker than the bed/strip practice
- ii) It can result a lower risk of severe compaction than the soil layer by layer practice, provided the soil is in a dry condition
- iii) If the soil horizons are stripped sequentially for each windrow, it offers flexibility in respect of short soil drying periods and likely wet weather as it is less susceptible to stoppages due to soil rewetting as a transpiring vegetation cover can be retained later into the stripping programme. Hence, it can be suited to northern and western, and

upland locations, and particularly when there are uncertain weather patterns.

The disadvantages are:

- i) Its beneficial effect is dependent on all the soil horizons being stripped as windrows, which may make it a slower more involved operation than the soil layer by layer practice
- ii) It requires skill and discipline, and a high level of supervision in its deployment, being suited to experienced operators
- iii) Whilst it can result in less soil compaction than other methods, it is likely some will be caused by the excavator moving on the soil during the formation of and operation of the windrows, and hence, there may be reliance on subsequent remedial treatment
- iv) Steep gradient/complex topographies may limit the safe and practical deployment of this machinery combination and handling practice.

Suitability

As the methodology involves the excavator operating on each layer of soils to form the successive windrows, there is a risk that compaction can occur and the likely reliance on remedial treatment with this practice. Hence, it is considered to be a less suitable practice than the bed/strip practice for minimizing the risk of soil compaction. The full benefit of the practice lies in the direct placement of the stripped soil and therefore requires the mineral extraction scheme to be organized to provide for this and minimize the need for soils storage.

Whilst it is not considered to be the ‘best practice’, the windrow practice may be acceptable in circumstances such as where there is a medium to high soil resilience to compaction (see **Table 7, Part One**) or the best available where:

- i) The soil profile in each designated windrow is stripped sequentially to the basal layer before progressing to the next
- ii) The dump trucks do not run on the in situ and the windrowed soils
- iii) It is used to recover a single surface soil layer
- iv) The intended after use, and environmental

and ecosystem services are less dependent on maintaining their full functional characteristics such as porosity and hence drainage and aeration, plant available water capacity, and low resistance to plant root growth. This may include the less productive agricultural and forestry land, many types of natural habitats, and where water storage/infiltration is of lesser importance for the risk of flooding. Where the soils are stored prior to replacement, effective remedial treatment may have to be relied upon

v) It is not suitable for soils with a low bearing capacity such as peat or organic soils, or soils having a high water table

vi) It is often considered to be the most suitable of the soil stripping practices available for important archaeological sites (see Box E.1).

MODEL METHODOLOGY

E.1 Key operational points to minimize the risk of severe soil compaction and soil wetness are summarised in Boxes E.2 and E.3.

Box E.2 - To minimize compaction:

- The dump trucks should normally only operate on the 'basal'/non-soil layer, and their wheels must not run on to the soil layer(s)
- The excavator only operates on the windrow with the dump trucks only travelling on the basal layer
- The machines are to only work when ground conditions enable their efficient operation
- The topsoil to be surcharged on the windrow as a thick layer as possible whilst maintaining the safe operation
- The soil layers are to be in 'dry' condition.

Box E.3 - To minimize the wetness of the soil and re-wetting of the soil:

- The progressive windrow system provides a basis to regulate the exposure of lower soil layers to periods of rain and a means of maintaining soil moisture contents. The soil profile within the active windrowed strip should be removed to the basal layer before rainfall occurs and before stripping is suspended
- Measures are required to protect the exposed face of the soil layer from ponding of water and maintain the basal layer in a condition capable of supporting dump trucks
- The area to be stripped is to be protected from in-flow of water, ponding etc. Wet sites should be drained in advance
- The maintenance of a transpiring crop is important, and an appropriate cropping regime should be established for the year of soil stripping
- Before stripping, excess vegetation should be removed; in the case of grassland it should be cut or grazed short and arable crops should have been harvested.

Box E.1

Stripping soils in windrows with an excavator is often the preferred practice when archaeological investigations and recording (as opposed to trial pit/trench sampling and 'watching briefs') are required as part of a planning consent. However, there may be a need for a deviation from normal good practice for soils with the excavator and dump trucks trafficking over the topsoil layer used as the haul route, and in some cases the surcharging of the topsoil for further protection of the archaeological feature. In these cases compaction of the topsoil will result and remedial treatment will have to be relied upon.

E.2 The timing of soil handling operations should only take place when the soils are in a 'dry and friable' condition (ie when it breaks and shatters when disturbed rather than smears and deforms) (see **Part One, Supplementary Note 4**). Prior to the start or recommencement of soil handling they should be tested to confirm they are in suitably dry condition (see Box E.4).

E.3 Soil handling is not to take place during rain, sleet or snow and in these conditions should be prohibited due to unsafe machine operating conditions. Prior to commencing operations, a medium/long term weather forecast should be obtained which gives reasonable confidence of soil handling being completed without significant interruptions from rainfall events. The soil based criteria set out in Box E.5 are to be used to determine whether soil handling should cease or be interrupted with the occurrence of rain.

E.4 All machines must be in a safe and efficient working condition at all times. The machines are to only work when ground conditions enable safe and efficient operation. Otherwise the operation is to be suspended until suitable remedial measures can be put in place.

E.5 The operation should follow the detailed stripping plan set out in the SRMP showing soil units to be stripped, haul routes and the phasing of vehicle movements. Different soil units to be kept separate are to be marked out and information to distinguish types and layers, and ranges of thickness needs to be conveyed to the operational supervisor/operator. The haul routes and soil storage areas must be defined and should be stripped first in a similar manner. Detailed daily records should be kept of operations undertaken, and site and soil conditions.

E.6 Within each soil unit the soil layers above the base/formation layer are to be stripped in sequential strips with the topsoil layer stripped first, followed by the subsoil layers; each layer stripped to its natural thickness without incorporating material from the lower layers. To protect the subsoil from becoming wet during changes in the weather, the next windrowed topsoil strip should not be started

Box E.4 - Test for Dry and Friable Soils

Soil tests are to be undertaken in the field. Samples shall be taken from at least five locations on the soil handling area and at each soil horizon to the full depth of the profile to be recovered/replaced. The tests shall include visual examination of the soil and physical assessment of soil consistency.

i) Examination

- If the soil is wet, films of water are visible on the surface of soil particles or aggregates (e.g. clods or peds) and/or when a clod or ped is squeezed in the hand it readily deforms into a cohesive 'ball' means **no soil handling to take place**
- If the sample is moist (i.e. there is a slight dampness when squeezed in the hand) but it does not significantly change colour (darken) on further wetting, and clods break up/crumble readily when squeezed in the hand rather than forming into a ball means **soil handling can take place**
- If the sample is dry, it looks dry and changes colour (darkens) if water is added, and it is brittle means **soil handling can take place**

ii) Consistency

First Test

Attempt to mould soil sample into a ball by hand:

- Impossible because soil is too dry and hard or too loose and dry means soil handling can take place
- Impossible because the soil is too loose and wet means no soil handling to take place
- Possible - GO TO SECOND TEST

Second Test

Attempt to roll ball into a 3mm diameter thread by hand:

- Impossible because soil crumbles or collapses means **soil handling can take place**
- Possible means **no soil handling to take place**

NB: It is impossible to roll most coarse loamy and sandy soils into a thread even when they are wet. For these soils, the Examination Test alone is to be used.

until the subsoil under lying the strip is completely stripped to the basal layer (**Figure E.1**). Stripping is to be undertaken by the excavator standing within the windrow strip and loading the surcharged soil layer into dump trucks.

Box E.5 - Rainfall Criteria:

- In light drizzle soil handling may continue for up to four hours unless the soils are already at/near to their moisture limit
- In light rain soil handling must cease after 15 minutes
- In heavy rain and intense showers, handling shall cease immediately

In all of the above, after rain has ceased, soil tests shall be applied to determine whether handling may re-start, provided that the ground is free from ponding and ground conditions are safe to do so.

Box E.6 - Choice of Bucket Type

For hard /stony soils toothed buckets are needed. Where the mixing of soil layers at their interface is to be minimized, a bucket with a 'blade' is preferable where the soil is 'soft' and free of large stones or particularly stony stone free.

Similarly, the choice of bucket type, whether it is a standard 'digging'/bulking or wide ditching type will depend on the soil strength and stoniness.

Bladed buckets will be required for soil stripping involving archaeological investigation. Where there is a watching archaeological brief, the use of bladed buckets will normally be required.

E.7 The type of bucket to be used largely depends on the nature of the soil (Box E.6).

E.8 Demarcate the windrow topsoil strips to be surcharged; the width of the soil strip to be recovered between the windrows is determined by the effective and safe excavator boom radius from the edge of each windrow; typically, about 3-4m (Box E7). Excavators with long booms ('long reach') can be used, but may be more restricted by gradient

Box E.7 - Orientation of the Excavator

Usually, the excavator is orientated and operates with its tracks at 90° to the axis of the bed being stripped as this is the most stable position.

Whilst the reach of the boom and hence the width of the bed/strip can be significantly increased and the excavator trafficking over the soil surface decreased by orientating it with the tracks parallel to edge of the soil being stripped, this may affect the stability of the excavator, particularly on a gradient or where soils have a low bearing capacity. Hence, its safe deployment needs to be checked before its adoption.

limitations, and require skilled and experienced operators.

E.9 The excavator is only to stand and work on the soil layers when stripping soils, otherwise it is to travel only on the basal/formation layer. The dump trucks are only to operate on the basal/formation layer. The exception is where it is stipulated that they are to traffic the topsoil for the protection of underlying archaeological features (see above Box E.1).

E.10 The top-soil layer is to be pulled up in the thickest layer possible onto the surcharged strip (**Figures E.1 & E.2**). It should be recovered to the full width of the segment being stripped without mixing with the underlying subsoil (not more than 20% of the lower horizon should be exposed at the layer junction within the strip). The thickness and identification of the horizon junction must be verified before and during stripping. The full thickness of the topsoil horizon should be stripped progressively before the underlying subsoil horizon(s), if present, is to be started. On completion of the topsoil windrow and its removal, the above procedures are repeated sequentially for each underlying soil horizon until the area is completely stripped of soil to the basal layer (**Figures E.3 & E.4**).

E.11 Where the soils are to be directly placed without storage in mounds, the initial strip of the upper horizons will have to be stored temporarily to

release the lowest layer and enable the sequential movement of materials.

The stored initial soil material would be placed on the lower layer removed from the final strip at the end of the programme or on partially completed profiles if rain were forecast.

E.12 When the stripping operation is likely to be interrupted by rain or there is likely to be overnight rain remove any exposed subsoil down to the basal layer before suspending operations. Make provisions to protect base of current or next strip from ponding/runoff by sumps and grips, and also clean and level the basal layer. At the start of each day ensure there is no ponding in the current strip or operating areas, and the basal layer is to level with no ruts.

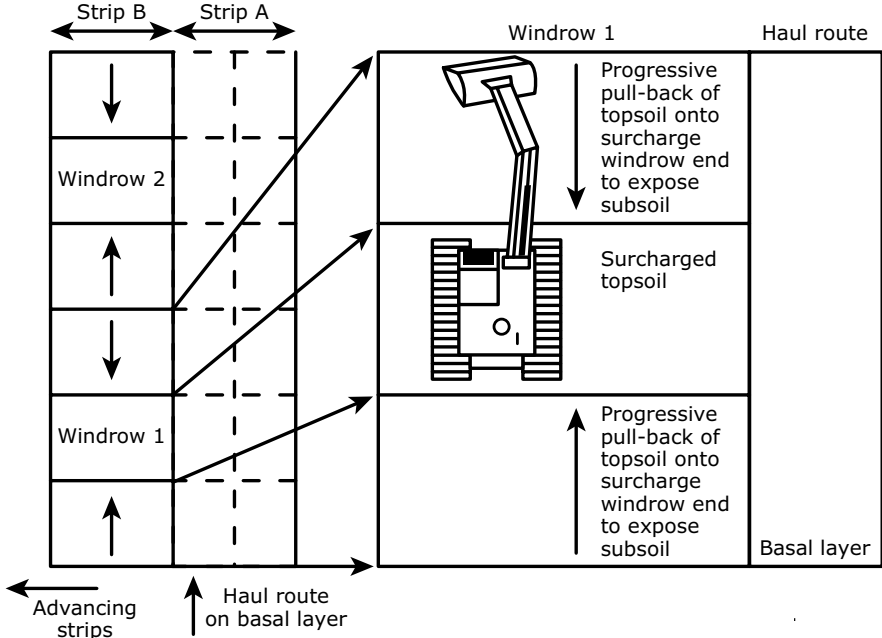

Figure E.1: Surcharging of windrow with topsoil.

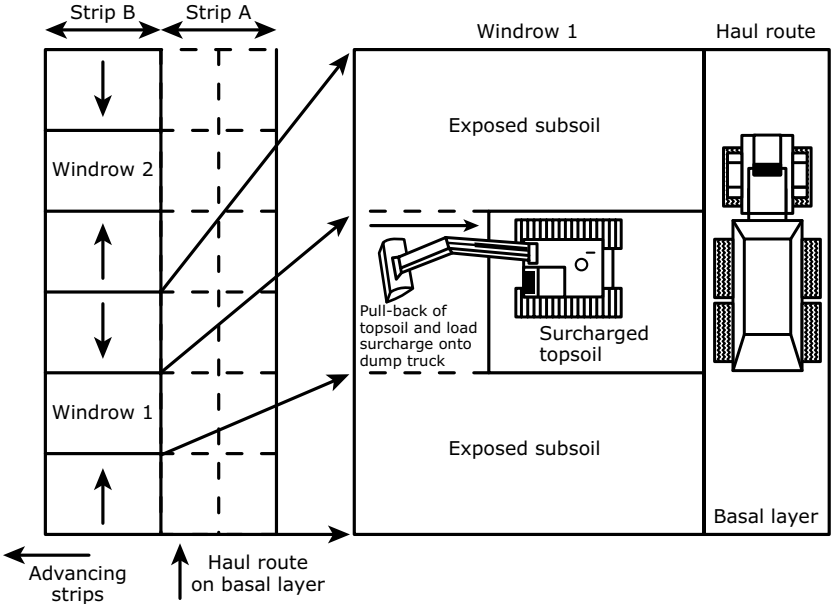

Figure E.2: Retreat of topsoil, surcharged windrow and loading of dump trucks.

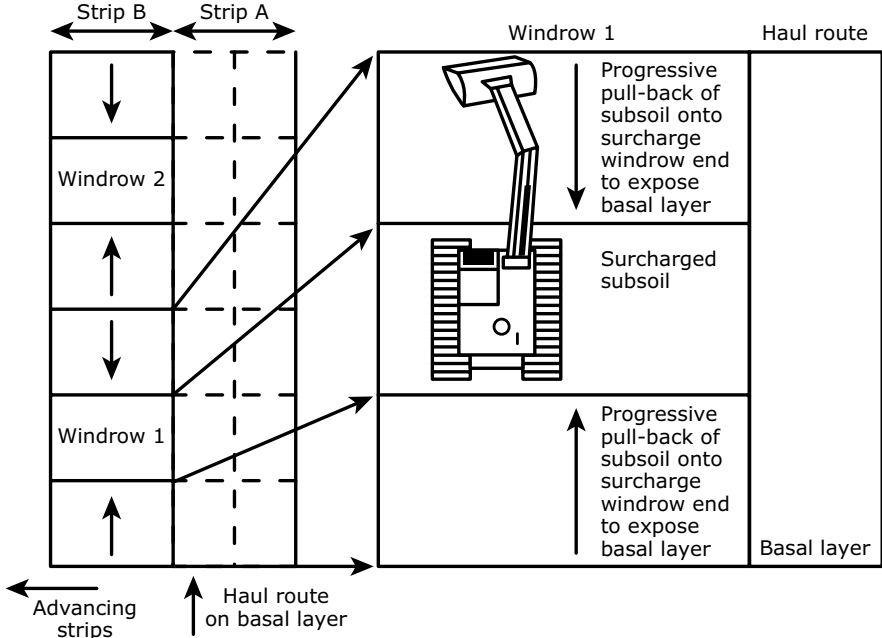

Figure E.3: Surcharging of windrow with subsoil.

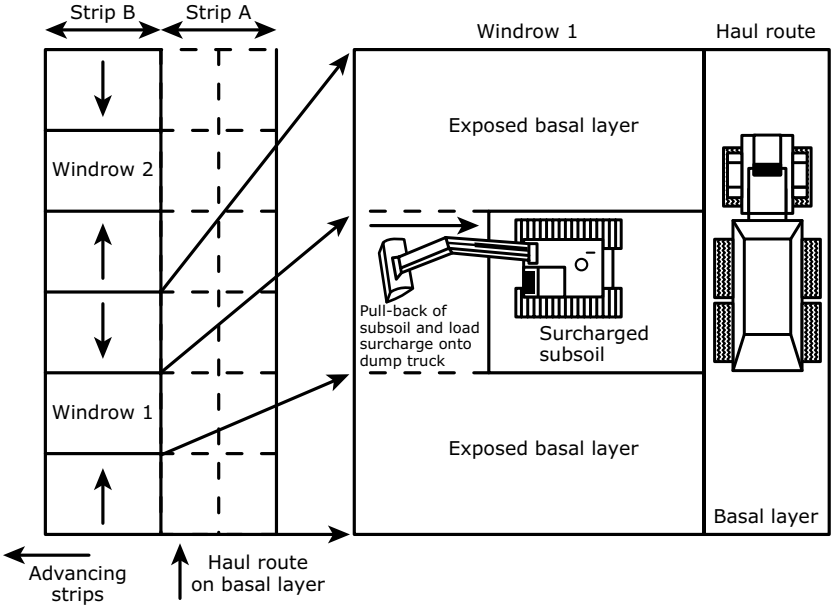

Figure E.4: Retreat of subsoil surcharged windrow and loading of dump trucks.

GOOD PRACTICE GUIDE FOR HANDLING SOILS

In Mineral Workings

PART TWO: Model Methodology

- Sheet F -

Soil Stripping with Bulldozers and Dump Trucks
- Windrow Practice

Author: Dr R N Humphries CBiol CSci FRSB FBSSS FIQ
- Blakemere Consultants Ltd & Celtic Energy Ltd

Supporting artwork was provided by R Shelton (H J Banks & Co)
and D Fisher (Blue Room Graphics Ltd).

Preface

The purpose of Sheet F of the guidance is to provide a model method of best practice where bulldozers and dump trucks are to be used to strip soil using the windrow practice.

The guidance is intended for use by planning officials, statutory consultees, mineral operators and their supporting teams and specialist consultants, and earth-moving contractors, their site supervisors and machine operators.

Successful soil handling schemes are dependent on the soil resources being clearly identified and the conditions in which they are to be handled. This information should be contained in the Soil Resource & Management Plan (SRMP) and communicated to those involved in its implementation.

Key issues to be addressed are:

- i) Avoiding conditions when soils are wet/plastic during handling
- ii) The minimisation of soil compaction caused by trafficking and soil wetness
- iii) Using appropriate remedial treatments where these are necessary
- iv) Minimising soil loss, and mixing of soil layers or different soil types.

The SRMP should specify the type of earth-moving machinery and soil handling practice, and the soil wetness condition (see Part One of the Guidance) to be deployed to achieve the planned after use, soil functioning, and the environmental and ecosystem services. It is to be communicated in full to all involved and in particular to the supervisors and machine operators by appropriate means; including tool-box talks and site demonstrations. Supervision by trained supervisory staff is essential, as are monitoring and reporting.

The guidance does not specify the size or model of equipment as this is left to the mineral operator and contractor to specify and provide. The machines must be of a kind which are appropriate for the task and the outcomes required, and to be able to carry out the work safely and efficiently.

Should the agreed methodology need to be modified or changed significantly, this should be agreed in advance with the mineral planning authority. The SRMP should include a mechanism whereby unexpected less significant changes can be quickly resolved through consultation between the operator, the planning authority and statutory consultee, and soil specialist.

All persons involved in the handling of soils must comply with all relevant legislation with respect to Health and Safety, in particular the Health and Safety at work Act 1974 and in the case of mineral extraction operations, The Quarries Regulations 1999 and its relevant statutory provisions; in particular those aspects which relate to the construction and removal of tips, mounds and similar structures. These requirements take preference over any suggested practice in this Sheet and the SRMP should have taken these into account.

The users of this guidance are solely responsible for ensuring it complies with all safety legislation and good practice, including the manufacturer's specifications for the safe operation of the specific machines being used, and that all machines are in a good condition and well maintained and are suitable for the task. It is important that those involved in the operation of earth moving machines are competent and have the necessary training and certification.

Introduction

In this soil handling option, bulldozers are used to strip the soil by heaping it into ‘windrows’, and back-acting excavators are used to load them into dump trucks for the direct transport to an area being restored or to storage until needed.

The windrow stripping practice, sometimes referred to as the ‘peninsular’ method, involves the sequential separation and removal of the individual layers of soil identified in the Soil Resource & Management Plan (SRMP). The area to be stripped is divided into spaced out parallel longitudinal strips (windrows) where alternative strips of topsoil from each side is pushed to surcharge the windrows acting as temporary repositories. The safe and efficient distance of the bulldozer’s push defines the width between the windrows. The topsoil on the retreating surcharged strips is then loaded by excavator into the dump trucks at the loading point on the haul route. On completing, the removal of the windrow the process is repeated for the next topsoil area to be stripped. The process using bulldozers is usually repeated across the area to be stripped of soils until all the topsoil layer is completely removed. Whilst the exposed subsoil layer, if present and to be recovered, can be by the same procedure of windrowing the common and more practical practice is the sequential lifting of the subsoil by the excavator with the trafficking and loading of dump trucks on the basal layer. The following guidance can also be adopted where only a single soil horizon is to be stripped.

Advantages & Disadvantages

The advantage of this machinery combination and handling practice are that:

- i) It is a relatively simple operation to undertake and can be quicker than both the excavator combination with the bed/strip and windrow practices.

The disadvantages are several:

- i) There is risk of compaction of the top- and subsoil layers by the repeated trafficking of the bulldozer, even if a low ground pressure machine is used, as it pushes soil to the windrows. Hence, subsequent remedial treatments are likely to be relied

- ii) upon
It is susceptible to stoppages due to soil rewetting as the transpiring vegetation cover is removed on stripping the topsoil
- iii) It is slow react to localised changes in soil types and variation in horizon depth, and can result in the mixing of soil horizons
- iv) It is not suited to the stripping of thin and ‘patterned’ soil layers, and cleanly exposing the top-sub-soil interface.

Suitability

This handling practice is not suitable where the subsoil surface needs to be carefully exposed for archaeological investigations and recording (as opposed to trial sampling).

Whilst the method is not considered ‘best practice’, it may be acceptable in circumstances where:

- i) The subsoil(s) have a high resilience to further compaction (see **Table 7, Part One**) and when decompaction treatments can be more relied upon to be effective because of a low risk of soil wetness (low rainfall areas/ prolonged dry conditions) or operational limitations (such as the availability of effective decompaction tools)
- ii) The intended after use, and environmental and ecosystem services are less dependent on maintaining functional characteristics such as soil porosity and hence drainage and aeration, plant available water capacity, and low resistance to plant root growth. This may include low productivity agricultural and forestry land, some types of natural habitats, and where water storage/infiltration is of lesser importance for the risk of flooding. Where the soils are stored prior to replacement, effective remedial treatment may have to be relied upon.
- iii) The soils are placed into storage stockpiles.

MODEL METHODOLOGY

F.1 Key operational points to minimize the risk of severe soil compaction and soil wetness are summarised in Boxes F.1 and F.2.

Box F.1 - To minimize compaction:

- The dump trucks should normally only operate on the 'basal layer, and their wheels must not in any circumstances run on to the soil layer(s)
- The machines are to only work when ground conditions enable their efficient operation
- The soils are to be stripped by the bulldozer in as thick layer as possible whilst maintaining their efficient operation
- The bulldozer should make the minimal number of passes over the soil as possible
- The soil layers are to be in 'dry' condition.

Box F.2 - To minimize the wetness of the soil and re-wetting of the soil:

- The windrow system provides a basis to regulate the exposure of lower soil layers to periods of rain and a means of maintaining soil moisture contents. The soil profile within the active strip should be stripped to the basal layer before rainfall occurs and before stripping is suspended
- Measures are required to protect the face of the soil layer from ponding of water and maintain the basal layer in a condition capable of supporting dump trucks
- The area to be stripped is to be protected from in-flow of water, ponding etc. Wet sites should be drained in advance
- The maintenance of a transpiring crop is important, and an appropriate cropping regime should be established for the year of soil stripping
- Before stripping, excess vegetation should be removed; in the case of grassland it should be cut or grazed short and arable crops should have been harvested.

F.2 The timing of soil handling operations should only take place when the soils are in a 'dry and friable' condition (ie when it breaks and shatters when disturbed rather than smears and deforms) (see Part One, Supplementary Note 4). Prior to the start or recommencement of soil handling they should be tested to confirm they are in suitably dry condition (see Box F.3).

Box F.3 - Test for Dry and Friable Soils

Soil tests are to be undertaken in the field. Samples shall be taken from at least five locations on the soil handling area and at each soil horizon to the full depth of the profile to be recovered/replaced. The tests shall include visual examination of the soil and physical assessment of soil consistency.

i) Examination

- If the soil is wet, films of water are visible on the surface of soil particles or aggregates (e.g. clods or peds) and/or when a clod or ped is squeezed in the hand it readily deforms into a cohesive 'ball' means **no soil handling to take place**
- If the sample is moist (i.e. there is a slight dampness when squeezed in the hand) but it does not significantly change colour (darken) on further wetting, and clods break up/crumble readily when squeezed in the hand rather than forming into a ball means **soil handling can take place**
- If the sample is dry, it looks dry and changes colour (darkens) if water is added, and it is brittle means **soil handling can take place**

ii) Consistency**First Test**

Attempt to mould soil sample into a ball by hand:

- Impossible because soil is too dry and hard or too loose and dry means soil handling can take place
- Impossible because the soil is too loose and wet means no soil handling to take place
- Possible - GO TO SECOND TEST

Second Test

Attempt to roll ball into a 3mm diameter thread by hand:

- Impossible because soil crumbles or collapses means **soil handling can take place**
- Possible means **no soil handling to take place**

NB: It is impossible to roll most coarse loamy and sandy soils into a thread even when they are wet. For these soils, the Examination Test alone is to be used.

F.3 Soil handling (by any machinery combination and handling practice) is not to take place during rain, sleet or snow and in these conditions should be prohibited due to unsafe machine operating conditions. Prior to commencing operations a medium/long term weather forecast should be obtained which gives reasonable confidence of soil handling being completed without significant interruptions from rainfall events. The soil based criteria set out in Box F.4 are to be used to determine whether soil handling should cease or be interrupted with the occurrence of rain.

Box F.4 - Rainfall Criteria:

- In light drizzle soil handling may continue for up to four hours unless the soils are already at/near to their moisture limit
- In light rain soil handling must cease after 15 minutes
- In heavy rain and intense showers, handling shall cease immediately.

In all of the above, after rain has ceased, soil tests shall be applied to determine whether handling may re-start, provided that the ground is free from ponding and ground conditions are safe to do so.

F.4 All machines must be in a safe and efficient working condition at all times. The machines are to only work when ground conditions enable safe and efficient operation. Otherwise the operation is to be suspended until suitable remedial measures can be put in place.

F.5 The operation should follow the detailed stripping plan set out in the SRMP showing soil units to be stripped, haul routes and the phasing of vehicle movements. Different soil units to be kept separate are to be marked out and information to distinguish types and layers, and ranges of thickness needs to be conveyed to the operational supervisor/operator. The haul routes and soil storage areas must be defined and should be stripped first in a similar manner. Detailed daily records should be kept of operations undertaken, and site and soil conditions.

F.6 Demarcate an initial surcharged top-soil strip and the width of the recovered soil as the effective

push distance of the bulldozer to the edge of the windrow (BOX F.5).

BOX F.5

Whilst there can be a lower of a risk of compaction when using wide tracked ('low ground pressure' (LGP)) bulldozers, in some circumstances they may require to traffic the soil surface more than standard machines to achieve the same work rate, and therefore the advantage of their use may be less than anticipated. However, the risk of severe compaction and reliance on remedial treatments may be less with the use of LGP machines.

F.7 Within each soil unit the topsoil layer is to be stripped across the area in sequential windrowed strips; the topsoil stripped to its natural thickness without incorporating material from the lower layer. Stripping of the topsoil is to be undertaken by the bulldozer standing on the surface and pushing the soil at its maximum thickness onto the windrow where the excavator loads the surcharged soil into the dump truck.

F.8 The topsoil layer is to be pushed up onto the windrow in the thickest layer possible with the minimal passes possible, whilst maintaining operational efficiency of the bulldozer, to form the low mound (**Figure F.1**). The topsoil should be recovered to the full width of the segment without mixing with sub-soil (not more than 20% of the lower horizon should be exposed at the layer junction within the strip). The thickness and identification of the horizon junction must be verified before and during stripping.

F.9 The soil furthest from the windrowed strip should be pushed first, progressively working to the front of the strip (**Figure F.1**). The topsoil is to be loaded into the dump truck stood on the basal layer by the excavator on the surcharged windrow (**Figure F.2**).

F.10 Unless the area is being stripped in segments to maintain vegetation and vegetated top-soil cover to protect as the subsoils from rewetting, the full thickness of the topsoil horizon would be stripped progressively across the area before the subsoil horizon(s) is stripped.

F.11 The subsoil layer(s) is to be recovered by repeating the above process with the bulldozer pushing the subsoil onto the new windrow with the excavator standing on the subsoil and loading onto the dump truck on the basal layer (**Figures F.3 & F.4**).

F.12 Where there is an upper subsoil to be recovered, if possible it is to be stripped as a windrow in the above manner. The lower subsoil would be recovered by the normal progressive lifting and loading by excavator from the subsoil layer with the dump trucks on the basal layer.

F.13 Where the soils are to be directly replaced without storage in mounds, the initial strip of the upper horizons will have to be stored temporarily to release the lowest layer and enable the sequential movement of materials. The stored initial soil material would be placed on the lower layer removed from the final strip at the end of the programme or on partially completed profiles if rain was forecast.

F.14 Where the stripping operation is likely to be interrupted by rain or there is likely to be overnight rain remove any exposed subsoil down to the basal layer before suspending operations. Make provisions to protect base of current or next strip from ponding/runoff by sumps and grips, and also clean and level the basal layer. At the start of each day ensure there is no ponding in the current strip or operating areas, and the basal layer is to level with no ruts.

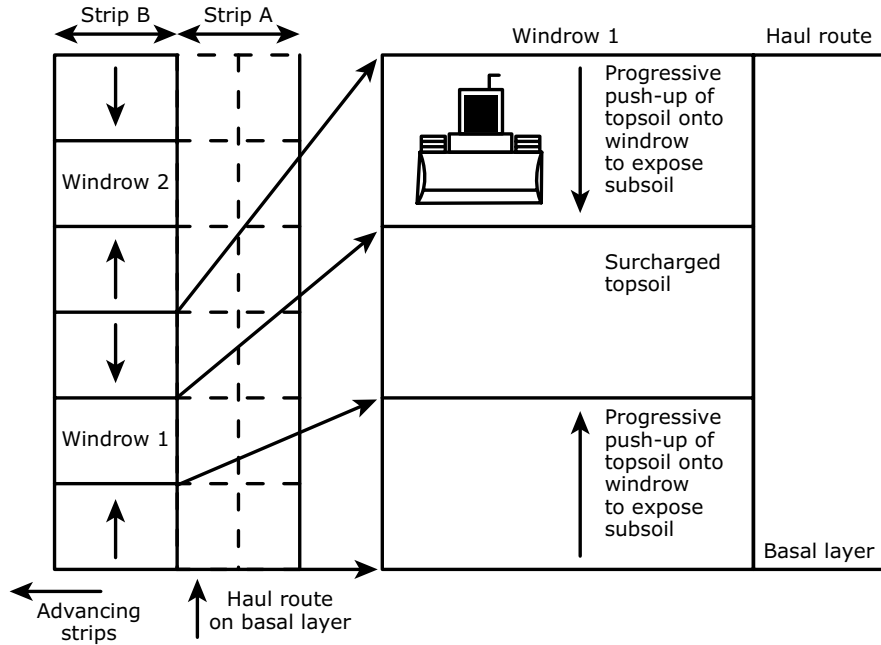

Figure F.1: Surcharging of windrow with topsoil.

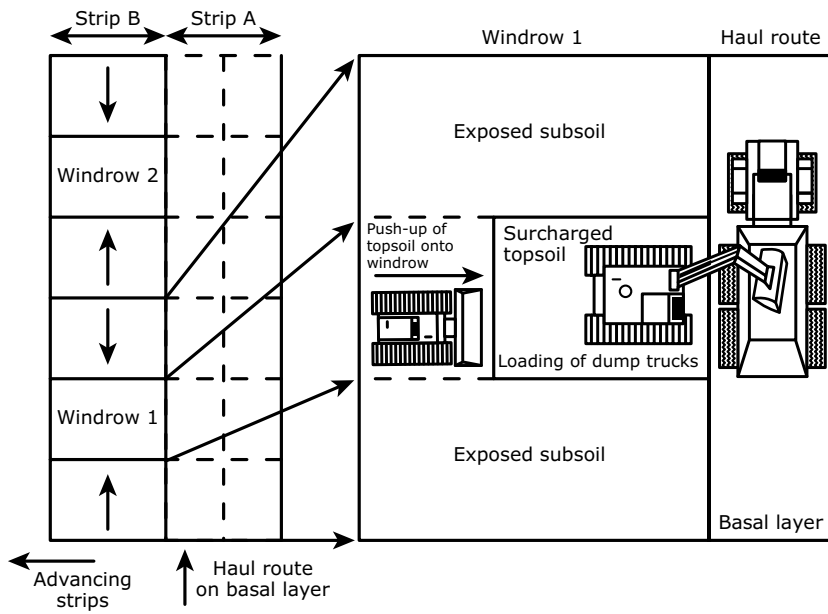

Figure F.2: Retreat of topsoil surcharged windrow and loading of dump trucks.

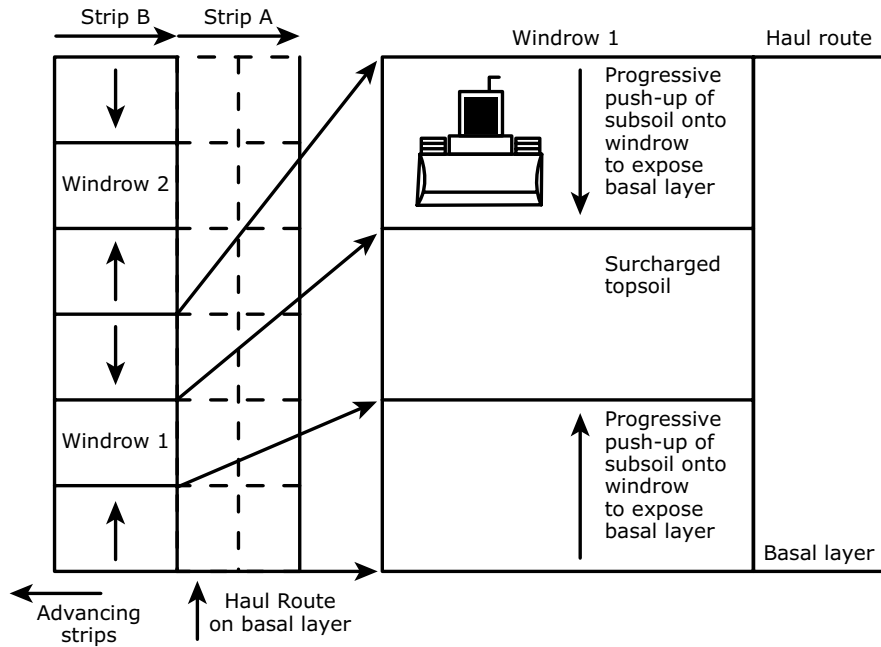

Figure F.3: Surcharging of windrow with topsoil.

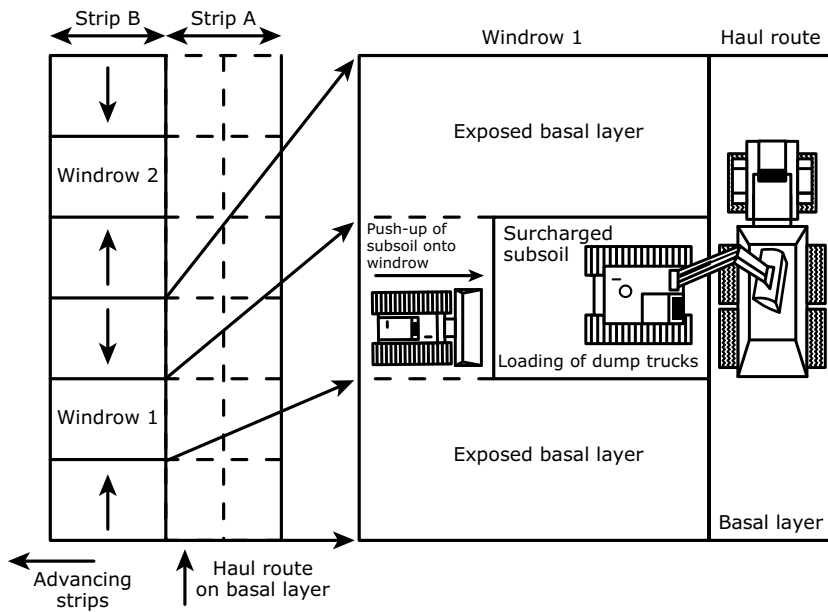

Figure F.4: Retreat of topsoil surcharged windrow and loading of dump trucks.

GOOD PRACTICE GUIDE FOR HANDLING SOILS

In Mineral Workings

PART TWO: Model Methodology

- Sheet G -

Building Soil Storage Mounds
with Bulldozers and Dump Trucks

Author: Dr R N Humphries CBiol CSci FRSB FBSSS FIQ
- Blakemere Consultants Ltd & Celtic Energy Ltd

Supporting artwork was provided by R Shelton (H J Banks & Co)
and D Fisher (Blue Room Graphics Ltd).

Preface

The purpose of Sheet G of the guidance is to provide a model method of best practice where bulldozers and dump trucks are used to build soil storage mounds.

The guidance is intended for use by planning officials, statutory consultees, mineral operators and their supporting teams and specialist consultants, and earth-moving contractors, their site supervisors and machine operators.

Successful soil handling schemes are dependent on the soil resources being clearly identified and the conditions in which they are to be handled. This information should be contained in the Soil Resource & Management Plan (SRMP) and communicated to those involved in its implementation.

Key issues to be addressed are:

- i) Avoiding conditions when soils are wet/ plastic during handling
- ii) The minimisation of soil compaction caused by trafficking and soil wetness
- iii) Using appropriate remedial treatments where these are necessary
- iv) Minimising soil loss, and mixing of soil layers or different soil types.

The SRMP should specify the type of earth-moving machinery and soil handling practice, and the soil wetness condition (see Part One of the Guidance) to be deployed to achieve the planned after use, soil functioning, and the environmental and ecosystem services. It is to be communicated in full to all involved and in particular to the supervisors and machine operators by appropriate means; including tool-box talks and site demonstrations. Supervision by trained supervisory staff is essential, as are monitoring and reporting.

The guidance does not specify the size or model of equipment as this is left to the mineral operator and contractor to specify and provide. The machines must be of a kind which are appropriate for the task and the outcomes required, and to be able to carry out the work safely and efficiently.

Should the agreed methodology need to be modified or changed significantly, this should be agreed in advance with the mineral planning authority. The SRMP should include a mechanism whereby unexpected less significant changes can be quickly resolved through consultation between the operator, the planning authority and statutory consultee, and soil specialist.

All persons involved in the handling of soils must comply with all relevant legislation with respect to Health and Safety, in particular the Health and Safety at work Act 1974 and in the case of mineral extraction operations, The Quarries Regulations 1999 and its relevant statutory provisions; in particular, those aspects which relate to the construction and removal of tips, mounds and similar structures. These requirements take preference over any suggested practice in this Sheet and the SRMP should have taken these into account.

The users of this guidance are solely responsible for ensuring it complies with all safety legislation and good practice, including the manufacturer's specifications for the safe operation of the specific machines being used, and that all machines are in a good condition and well maintained and are suitable for the task. It is important that those involved in the operation of earth moving machines are competent and have the necessary training and certification.

Introduction

This soil handling method uses low ground pressure bulldozers to build the storage mound in combination with dump trucks to transport the soil. Top- and subsoil(s) are to be stored in separate mounds or in clearly defined parts of mounds, in some circumstances where the topsoil can be easily recovered it may be laid over the subsoil.

The space available for storage in mineral workings is often limited and this determines the 'height' of mounds. For topsoil, the preference is for 1 to 3m height in order to minimize the impact of storage on biological processes, whereas for subsoils where the biological activity is lower, subject to safe operations, mounds are often raised to heights of 3 to 5m depending on the resilience of the soils to compaction (see **Part One & Supplementary Note 3**).

In this soil handling option, the mounds are either built as one 'tier' or 'multi-tier' high. In the single tier only the bulldozer traffic the soil surface and usually the final surface. In the multi-tier, the mound is also trafficked by loaded dump trucks.

Advantages & Disadvantages

Storage vs Direct Placement:

The advantages of storage are:

- i) It gives flexibility in the operation of the mineral site
- ii) Flexibility (i.e., weather and ground conditions) when it is reused.

The disadvantages are:

- i) There is a high risk of compaction of the soil material by stacking in the mound which later cannot be effectively treated
- ii) There may be significant degradation of biological functions with long-term storage.

Single vs Multi-tier Mounds:

The advantage of multi-tier mounds is that they take less space. The disadvantages are:

- i) With multi-tier mounds there is high risk of severe compaction of the soil material layers by repeated trafficking by laden dump trucks

in the building of multi-tier mounds which later cannot be effectively treated

- ii) There may be a longer delay in recovery of the soil's biological functions on replacement.

Suitability

Soil storage is less suitable where:

- i) The subsoil(s) are significantly less resilient to compaction (such as silts and sandy clay loams) and when decompaction treatments cannot be relied upon to be effective because of a risk of soil wetness operational limitations (such as the unavailability of effective decompaction tools) (see **Part One and Supplementary Notes 3 & 4**)
- ii) The intended after use, and environmental and ecosystem services are dependent on maintaining functional characteristics such as soil porosity and hence drainage and aeration, plant available water capacity, and low resistance to plant root growth. This usually includes the most productive agricultural, horticultural and forestry land, many types of natural habitats, and where water storage/infiltration is of importance for the risk of flooding
- iii) The bed/strip practice using excavators is used (**Sheet A**) as the compaction caused can negate its benefit
- iv) Multi-tier mounds are used, particularly where the intended after use, and the environment and ecosystem services are dependent on maintaining functional characteristics such as soil porosity and hence drainage and aeration, plant available water capacity, and low resistance to plant root growth. This usually includes the most productive agricultural and forestry land, many types of natural habitats, and where water storage/infiltration is not of importance for the risk of flooding.

MODEL METHODOLOGY

G.1 Key operational points to minimize the risk of severe soil compaction and soil wetness are summarised in Boxes G.1 and G.2.

Box G.1 - To minimize compaction:

- Strip in advance the soil to basal layer along haul routes and the operational footprint of the storage mound
- The soils are to be pushed by the bulldozer to form the mound in as thick layers as possible whilst maintaining their efficient operation
- The machines are to only work when ground or soil surface conditions enable their efficient operation
- The dump trucks should only operate on the 'basal'/non-soil layer, and their wheels must not in any circumstances run on to the tipped soil
- In the raising of multi-tier mounds, trafficking is to be confined to the upper surface of the lower tier. This layer will require decompaction on excavation of the mound.

Box G.2 - To minimise the wetting of soils:

- Site soil mounds in dry locations and protect from run-off from adjacent areas. Drain if a wet location
- Raise the soil mound to maximum height progressively along the axis of the mound and shape the mound as it is being built to shed water and whenever stripping is suspended
- Measures are required to protect the face of the soil layer from ponding of water and maintain the basal layer in a condition capable of supporting dump trucks.

G.2 The timing of the building of the soil storage mounds will be governed by the weather and soil conditions governing stripping (see **Sheets A, E, F, I**). The mounds should be sited on dry ground and not in hollows and should not disrupt local surface drainage (Box G.3). Where necessary mounds should be protected from run-off/ponding by a cut-off ditch which is linked to appropriate water discharge facilities. Where the storage mound is in a hollow due to the removal of surface soils, measures should be undertaken to ensure that water is not able to pond within the storage area.

G.3 All machines must be in a safe and efficient working condition at all times. The machines are to

Box G.3

Where soils such as peat need to be kept in a wet condition this may require storage in bunded cells where receiving rainfall cannot drain. Here, the use of bulldozers is not appropriate for handling peat, and excavators and dump trucks are to be used (**Sheets A – D**).

only work when ground conditions enable safe and efficient operation. Otherwise the operation is to be suspended until suitable remedial measures can be put in place.

G.4 The operation should follow the detailed stripping/storage plan set out in the SRMP showing soil units to be stripped, haul routes and the phasing of vehicle movements. Different soil units to be kept separate are to be marked out and information to distinguish types and layers, and ranges of thickness needs to be conveyed to the operational supervisor/operator. The haul routes and soil storage areas must be defined and should be stripped first in a similar manner. Detailed daily records should be kept of operations undertaken, and site and soil conditions.

G.5 Adopting the practices outlined in **Sheets A, F** or **I**, where relevant, remove topsoil and subsoil to basal layer from the haul routes, footprint of the storage mound and any other operating area in advance. The soils should be stored in their respective mounds.

G.6 The dump trucks must only travel within the haul route and operational areas. The trucks should enter the storage area, reverse and tip the soil load starting at the furthest point of the mound from the point of access.

G.7 The low ground pressure bulldozer pushes the soil into a mound of the required dimensions (**Figure G.1**). The bulldozer is used to shape the sides as the mound is progressively formed to promote the shedding of rain, particularly at the end of each day, but also on the onset of rain during the day. This should include any exposed incomplete surfaces.

G.8 The process is repeated with the tipping of soil against the forming mound, and without the dump truck wheels traversing onto previously tipped material. The operation continues progressively along the main axis of the mound. Without the trucks rising onto the soil mound, the typical height of a mound raised by bulldozer is in the order of 4-6m.

G.9 Work should stop in wet conditions (Box G.4) with measures undertaken to shed water from the soil surfaces and to prevent ponding at the base of the mound and on the basal layer. At the start of each day ensure there is no ponding on the basal layers and operating areas.

Box G.4 - Rainfall Criteria:

- In light drizzle soil handling may continue for up to four hours unless the soils are already at/near to their moisture limit
- In light rain soil handling must cease after 15 minutes
- In heavy rain and intense showers, handling shall cease immediately

In all of the above, after rain has ceased, soil tests shall be applied to determine whether handling may re-start, provided that the ground is free from ponding and ground conditions are safe to do so.

G.10 To raise the mound higher, the trucks will have to travel on the upper surface of the mounded soils, or long reach excavators used to cast-up the soil. In this case the mound should be raised to its maximum height (**Figure G.2**). A ramp will have to be provided for the trucks to rise onto the surface of the first tier, which should be capable of trafficking without difficulty. The next tier would be formed repeating the process described above. If further tiers are required, the process would be repeated again.

G.11 Any exposed edges/surfaces should be shaped using the bulldozer blade on the onset of rain during the day. All surfaces should be shaped to shed water at the end of the day. The final outer surface should be progressively shaped using the

bulldozer blade to promote the shedding of rain.

G.12 Work should stop in wet conditions (Box G.4) with measures undertaken to prevent ponding at the base of the mound and on the basal layer. At the start of each day ensure there is no ponding on the basal layers and operating areas.

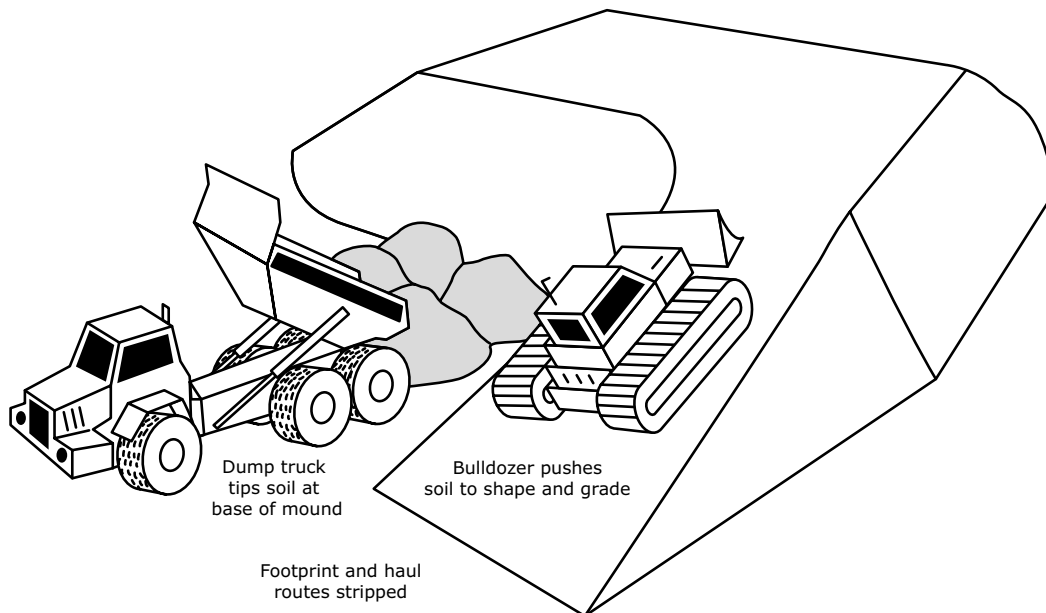

Figure G.1: Soil storage mound construction with bulldozer and dump trucks: Single tier mound.

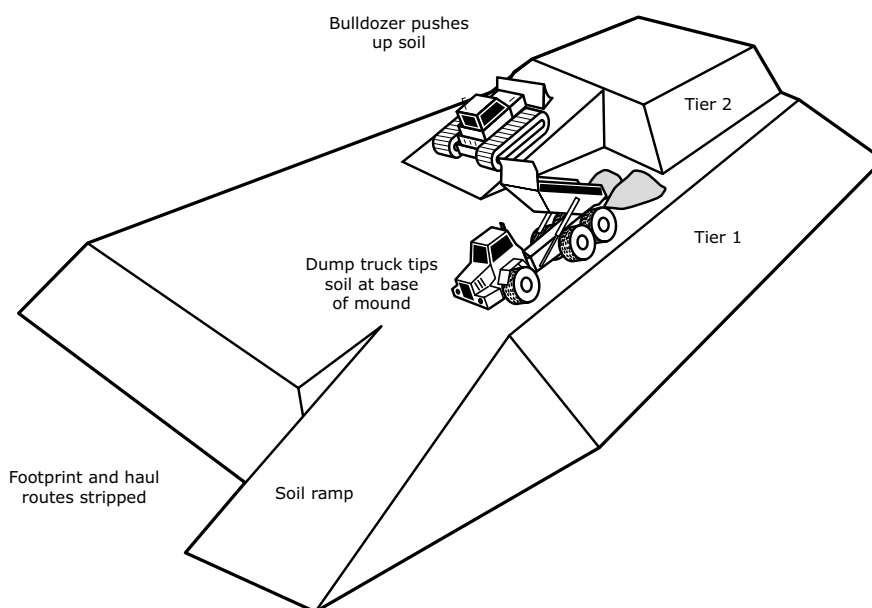

Figure G.2: Soil storage mound construction with bulldozers and dump trucks: Multi-tier mound..

GOOD PRACTICE GUIDE FOR HANDLING SOILS

In Mineral Workings

PART TWO: Model Methodology

- Sheet H-

Soil Replacement with Bulldozers and Dump Trucks
- Windrow Practice

Author: Dr R N Humphries CBiol CSci FRSB FBSSS FIQ
- Blakemere Consultants Ltd & Celtic Energy Ltd

Supporting artwork was provided by R Shelton (H J Banks & Co)
and D Fisher (Blue Room Graphics Ltd).

Preface

The purpose of Sheet H of the guidance is to provide a model method of best practice where bulldozers and dump trucks are to be used to replace soil using the windrow practice.

The guidance is intended for use by planning officials, statutory consultees, mineral operators and their supporting teams and specialist consultants, and earth-moving contractors, their site supervisors and machine operators.

Successful soil handling schemes are dependent on the soil resources being clearly identified and the conditions in which they are to be handled. This information should be contained in the Soil Resource & Management Plan (SRMP) and communicated to those involved in its implementation.

Key issues to be addressed are:

- i) Avoiding conditions when soils are wet/plastic during handling
- ii) The minimisation of soil compaction caused by trafficking and soil wetness
- iii) Using appropriate remedial treatments where these are necessary
- iv) Minimising soil loss, and mixing of soil layers or different soil types.

The SRMP should specify the type of earth-moving machinery and soil handling practice, and the soil wetness condition (see Part One of the Guidance) to be deployed to achieve the planned after use, soil functioning, and the environmental and ecosystem services. It is to be communicated in full to all involved and in particular to the supervisors and machine operators by appropriate means; including tool-box talks and site demonstrations. Supervision by trained supervisory staff is essential, as are monitoring and reporting.

The guidance does not specify the size or model of equipment as this is left to the mineral operator and contractor to specify and provide. The machines must be of a kind which are appropriate for the task and the outcomes required, and to be able to carry out the work safely and efficiently.

Should the agreed methodology need to be modified or changed significantly, this should be agreed in advance with the mineral planning authority. The SRMP should include a mechanism whereby unexpected less significant changes can be quickly resolved through consultation between the operator, the planning authority and statutory consultee, and soil specialist.

All persons involved in the handling of soils must comply with all relevant legislation with respect to Health and Safety, in particular the Health and Safety at work Act 1974 and in the case of mineral extraction operations, The Quarries Regulations 1999 and its relevant statutory provisions; in particular those aspects which relate to the construction and removal of tips, mounds and similar structures. These requirements take preference over any suggested practice in this Sheet and the SRMP should have taken these into account.

The users of this guidance are solely responsible for ensuring it complies with all safety legislation and good practice, including the manufacturer's specifications for the safe operation of the specific machines being used, and that all machines are in a good condition and well maintained and are suitable for the task. It is important that those involved in the operation of earth moving machines are competent and have the necessary training and certification.

Introduction

In this handling option, bulldozers are used to spread the replaced soil from series of linear surcharged strips (windrows). The windrow replacement practice is sometimes referred to as the ‘peninsular’ method.

It involves the sequential replacement of the individual layers of soil identified in the Soil Resource & Management Plan (SRMP). The method can be used for both top and subsoil.

The area to be replaced is divided into windrows from which excess soil is pushed out (from each side) over the adjacent unsoiled parts. The efficient operational distance of the bulldozers push and the safe height for the dump trucks to reverse and tip the soils defines the height of the surcharged windrow and the distance between the windrows. The following guidance can also be adopted where only a single soil horizon is to be replaced.

There is a hybrid excavator and bulldozer practice (see **Sheet K**) often referred to as a ‘loose-tipping’ method without the use of windrows where the subsoil(s) is replaced by the excavator method (**Sheet D**) with the topsoil then spread by bulldozer.

Advantages & Disadvantages

The advantages of this machinery combination and handling practice are:

- i) It is a relatively simple operation to undertake and can be quicker than the excavator combination with the bed/strip practice
- ii) If the practice is applied sequentially across the site, the windrow replacement practice can offer flexibility in respect of short dry periods and likely wet weather, operationally, it can be less prone to delays and stoppages in uncertain weather patterns.

The disadvantages are several:

- i) There is risk of compaction of the replaced soil layers by repeated trafficking by the bulldozer and the loaded dump trucks as they enter and tip the soils on the windrows. Hence, remedial treatments are likely to be relied upon
- ii) It can cause patterned ground due to

uneven soil depths and where some areas are more compacted than others

- iii) It is more difficult to create localised changes in soil types and variation in horizon depth over short distances.

Suitability

Whilst the method is not considered ‘best practice’, it may be acceptable in circumstances where:

- i) The subsoil(s) have a high resilience to further compaction (see **Part One**) and when decompaction treatments can be more relied upon to be effective because of a low risk of soil wetness (low rainfall areas/prolonged dry conditions) or operational limitations (such as the availability of effective decompaction tools)
- ii) The intended after use, and environmental and ecosystem services are less dependent on maintaining functional characteristics such as soil porosity and hence drainage and aeration, plant available water capacity, and low resistance to plant root growth. This may include low productivity agricultural and forestry land, some types of natural habitats, and where water storage/infiltration is of lesser importance for the risk of flooding. Where the soils are stored prior to replacement, effective remedial treatment may have to be relied upon
- iii) It is suited to the placement of a single layer of topsoil rather than a series of soil layers
- iv) The soils have been placed into storage stockpiles.

MODEL METHODOLOGY

Basic Soil Replacement Operation

H.1 The following is the basic model methodology using bulldozers with dump trucks and the windrow practice. It is presented here, firstly without any remedial interventions to give clarity of the methodology. The methodology is then repeated with interventions to demonstrate how integration is to be achieved.

H.2 Key operational points to minimise the risk of severe soil compaction and soil wetness are summarised in Boxes H.1 and H.2.

Box H.1 - To minimize compaction:

- The dump trucks should only operate on the 'basal'/non-soil layer when not entering the windrows
- The machines are to only work when ground conditions enable their efficient operation
- The soils are to be spread by the bulldozer in as thick layer as possible whilst maintaining their efficient operation
- The bulldozer should make the minimal number of passes over the soil as possible
- The soil layers are to be in 'dry' condition

Box H.2 - To minimize the wetness of the soil and re-wetting of the soil:

- The windrow system provides a basis to regulate the exposure of lower soil layers to periods of rain and a means of maintaining soil moisture contents. The soil profile within the active strip should be replaced to the topsoil surface layer before rainfall occurs and before replacement is suspended
- Measures are required to protect the face of the soil layer from ponding of water and maintain the basal layer in a condition capable of supporting dump trucks
- The area to be restored is to be protected from in-flow of water, ponding etc. Wet sites must be drained in advance. Before the operation starts the basal layer should be to level and clean.

H.3 The timing of soil handling operations should only take place when the soils are in a 'dry and friable' condition (ie when it breaks and shatters when disturbed rather than smears and deforms) (see **Part One, Supplementary Note 4**). Prior to the start or recommencement of soil handling they should be tested to confirm they are in suitably dry condition (see Box H.3).

H.4 Soil handling (by any machinery combination and handling practice) is not to take place during rain, sleet or snow and in these conditions should be prohibited due to unsafe machine operating conditions. Prior to commencing operations a medium/long term weather forecast should be

Box H.3 - Test for Dry and Friable Soils

Soil tests are to be undertaken in the field. Samples shall be taken from at least five locations on the soil handling area and at each soil horizon to the full depth of the profile to be recovered/replaced. The tests shall include visual examination of the soil and physical assessment of soil consistency.

i) Examination

- If the soil is wet, films of water are visible on the surface of soil particles or aggregates (e.g. clods or peds) and/or when a clod or ped is squeezed in the hand it readily deforms into a cohesive 'ball' means **no soil handling to take place**
- If the sample is moist (i.e. there is a slight dampness when squeezed in the hand) but it does not significantly change colour (darken) on further wetting, and clods break up/crumble readily when squeezed in the hand rather than forming into a ball means **soil handling can take place**
- If the sample is dry, it looks dry and changes colour (darkens) if water is added, and it is brittle means **soil handling can take place**

ii) Consistency**First Test**

Attempt to mould soil sample into a ball by hand:

- Impossible because soil is too dry and hard or too loose and dry means soil handling can take place
- Impossible because the soil is too loose and wet means no soil handling to take place
- Possible - GO TO SECOND TEST

Second Test

Attempt to roll ball into a 3mm diameter thread by hand:

- Impossible because soil crumbles or collapses means **soil handling can take place**
- Possible means **no soil handling to take place**

NB: It is impossible to roll most coarse loamy and sandy soils into a thread even when they are wet. For these soils, the Examination Test alone is to be used.

obtained which gives reasonable confidence of soil handling being completed without significant interruptions from rainfall events. The soil based criteria set out in Box H.4 are to be used to determine whether soil handling should cease or be interrupted with the occurrence of rain.

Box H.4 - Rainfall Criteria:

- In light drizzle soil handling may continue for up to four hours unless the soils are already at/near to their moisture limit
- In light rain soil handling must cease after 15 minutes
- In heavy rain and intense showers, handling shall cease immediately

In all of the above, after rain has ceased, soil tests shall be applied to determine whether handling may re-start, provided that the ground is free from ponding and ground conditions are safe to do so.

H.5 All machines must be in a safe and efficient working condition at all times. The machines are to only work when ground conditions enable safe and efficient operation. Otherwise the operation is to be suspended until suitable remedial measures can be put in place.

Box H.5

Whilst there can be a lower of a risk of compaction when using wide tracked ('low ground pressure' (LGP)) bulldozers, in some circumstances they may require to traffic the soil surface more than standard machines to achieve the same work rate, and therefore the advantage of their use may be less than anticipated. However, the risk of severe compaction and reliance on remedial treatments may be less with the use of LGP machines.

H.6 The operation should follow the detailed soil plan set out in the SRMP showing soil units to be replaced, haul routes and the phasing of vehicle movements. Different soil units to be kept separate are to be marked out and information to distinguish types and layers, and ranges of thickness needs to

be conveyed to the operational supervisor/operator. The haul routes and soil storage areas must be defined and should be replaced in a similar manner. Detailed daily records should be kept of operations undertaken, and site and soil conditions.

Box H.6

As a general rule, a moving loaded dump truck can exert sufficient pressure to cause compaction of loose soil to a depth of 40 – 60cm depending on its wetness.

H.7 Either the process progresses across the site until there is a complete subsoil cover before topsoil is replaced or it is done in sections with the full profile being completed before another is started. The latter sequential approach has the advantage that a large expanse of subsoil is not exposed to wetting prior to top-soiling.

H.8 Profile boards should be used to control soil horizon thickness being replaced and overall levels achieved verified using soil pits.

Box H.7 - Integration of Decompaction & Stone/Debris Removal

Option 1: is where the basal layer needs to be treated but is left until the subsoil is placed when both are decompacted together, followed by the decompaction of the topsoil and subsoil layers together (and basal layer) using tines that are long enough. This option is not suited to digging where the soil horizons would be mixed.

Option 2: is where each layer is treated separately by either tines or digging.

Option 3 is where the basal layer is treated or left untreated, followed by the placement of the subsoil and topsoil layers, which are to be decompacted by the use of tines. In the case of deep horizons this option can be limited by the capability of the machinery, the tines or bucket used. This option is not suited to digging where the soil horizons would be mixed.

H.9 The bulldozer is to work and travel on the soil layers (Box H.5). The dump trucks should avoid reversing onto the windrows until they have been surcharged sufficiently to buffer any underlying functional soil layer from compaction.

H.10 The area to be soiled is divided into a series of windrows on which the first loads of subsoil are pushed out by bulldozer to form the windrow of subsoil of 400 – 600mm thick (Box H.6). It is then surcharged with further subsoil being tipped by dump trucks reversing over the initial layer (**Figures H.1 – H.2**). The excess soil on the surcharged windrows is pushed out laterally by the bulldozer to cover the area between the windrows to the required depth.

H.11 On completion of the subsoil placement, the topsoil is replaced by the above procedure (**Figure H.3 & H.4**). The dump trucks should avoid reversing onto the windrows until they have been surcharged to buffer any underlying functional subsoil/basal layer from compaction (see Box H.6).

H.12 At the end of each day the current sector with soils being replaced must be completed if rain is forecast. If during a day it is evident that a full windrow cannot be completed, then that part must be completed to topsoil level.

H.13 At the end of each day, or during the day if interrupted by rain, make provisions to protect base of restored strip from ponding/runoff by sumps and grips, and also clean and level the basal layer. At the start of each day ensure there is no ponding in the current strip or operating areas, and the basal layer is to level with no ruts.

Methodology with Remedial Actions

H.14 The following is the model methodology, using bulldozers with dump trucks for the windrow practice, with the remedial interventions to demonstrate how integration is to be achieved. The key operational points to minimise the risk of severe soil compaction and soil wetness are summarised in the above Boxes H.1 and H.2.

H.15 Usually there will be a need for decompaction treatment during the replacement operation with this

methodology. Where compaction occurs, treatment will need integrating into the replacement process as will any need for the removal of stones or non-soil debris within the replacement process. Both decompaction and removal of materials procedures are covered in separate **Sheets L to O**.

H.16 The placement of the stripped soils in storage is likely to have contributed to the compaction. Box H.7 sets out some of the remedial options/ combinations to facilitate decompaction, and where necessary, the removal of stones and non-soil debris for a final profile comprising a basal layer, subsoil and topsoil layers. Except for Option 3, these actions need to be undertaken sequentially as each soil strip is placed.

H.17 Prior to commencing operations a weather forecast should be obtained which gives reasonable confidence of soil replacement proceeding without interruptions from rainfall events (Box H.4).

H.18 If significant rainfall occurs during operations, the replacement must be suspended, and where the soil profile has been started it should be replaced to the topsoil level. Replacement must not restart unless the weather forecast is expected to be dry for at least a full day and the soils are in a dry condition (see above Box H.3).

H.19 All machines must be in a safe and efficient working condition at all times. The machines are only to work when ground conditions enable their efficient operation. The work should only be carried out when the basal layer supports the machinery without ruts or is capable of repair/maintenance. Otherwise the operation is to be suspended until suitable remedial measures can be put in place.

H.20 The operation should follow the detailed replacement plan in the SRMP showing the soil units to be replaced, haul routes and the phasing of vehicle movements. The soil units should be defined on the site with information to distinguish types and layers, and thickness and conveyed to the operational supervisor/operator. Different soil units to be kept separate are to be marked out and information to distinguish types and layers, and ranges of thickness needs to be conveyed to

the operational supervisor/operator. Detailed daily records should be kept of operations undertaken and site and soil conditions (including the removal of stones and other non-soil debris that needs to be removed), and the results of the effectiveness of the work undertaken, and any need for additional remedial treatments.

H.21 Profile boards should be used to control soil horizon thickness being replaced and overall levels achieved verified using soil pits. Allowances (ie. bulking factor) should be made for any 'heave' that may take place when the replaced soil is decompacted.

H.22 Only the bulldozer is to work and travel on the soil layers. The dump trucks should avoid reversing onto the windrows until they have been surcharged sufficiently to buffer any underlying functional soil layer from compaction (see above BOX H.6).

H.23 The area to be soiled is divided into a series of windrows. Where there is a requirement to treat compaction and/or remove stones/non-soil debris in the basal layer, these need to be carried out in the area to be soiled (including the windrows being formed).

H.24 Where there is a requirement to treat compaction and/or remove stones and non-soil debris in the basal layer, these need to be carried out in the area to receive the subsoil. Decompaction can be by digging with the excavator bucket or by bulldozer drawn tines (**Sheets N & O**). Stone removal may require prior ripping/digging to release them from the soil, followed by the excavator using a stone-rake bucket (to be loaded on a dump truck and removed) (**Sheets L & M**). Where these treatments are deployed, to minimise additional compaction/recompaction, only the bulldozer need to work and traffic the basal layer and the soil surfaces, and the excavator and the dump truck being loaded with the recovered stones/debris stand and travel on the untreated basal layer.

H.25 On completion of the remedial work, the subsoil windrow is formed as described above with the bulldozer pushing out the excess sub-soil to cover the area to the required depth (**Figures H.1**

& H.2). The dump trucks should avoid reversing onto the windrows, particularly until they have been surcharged to buffer any underlying functional basal layer from compaction.

H.26 On completion of the subsoil placement, where there is a requirement to treat compaction and/or remove stones/non-soil debris in the subsoil layer, these need to be carried out prior to the topsoil being laid.

H.27 Where there is a requirement to treat compaction and/or remove stones and non-soil debris in the subsoil, these need to be carried out prior to the topsoil layer of soil being laid. Decompaction can be by digging with the excavator bucket or by bulldozer drawn tines (**Sheets N & O**). Stone removal may require prior ripping/digging to release them from the subsoil, followed by the excavator using a stone-rake bucket (to be loaded on a dump truck and removed) (**Sheets L & M**). Where these treatments are deployed, to minimise additional compaction/recompaction, only the bulldozer need to work and traffic the subsoil layer, and the excavator and the dump truck being loaded with the recovered stones/debris stand and travel on the untreated basal layer.

H.28 The topsoil is replaced by the same windrow procedure as described above (see above H.10 & H.11) with the bulldozer pushing out the excess topsoil to cover the area to the required depth (**Figures H.3 & H.4**). The dump trucks should avoid reversing onto the windrows, particularly until they have been surcharged to buffer any underlying functional sub-soil layer from compaction (Box H.6).

H.29 Where there is a requirement to treat compaction and/or remove stones and non-soil debris in the topsoil, decompaction can be by digging with the excavator bucket or by bulldozer drawn tines (**Sheets N & O**). Stone removal may require prior ripping/digging to release them from the topsoil, followed by the excavator using a stone-rake bucket (to be loaded on a dump truck and removed) (**Sheets L & M**). Where these treatments are deployed, to minimise additional compaction/recompaction, only the bulldozer need to work and traffic the topsoil, and the excavator and the dump

truck being loaded with the recovered stones/debris stand and travel on the untreated basal layer.

H.30 In some circumstances decompaction can be undertaken from the top-soil surface once the placing of the soils is complete (Box H.7, Option 3). Here, stone and non-soil debris removal would be restricted to the topsoil layer.

However, this Option is only advisable where it is certain that it will be effective and will not compromise the achievement of the intended after use, soil functions, and environmental and ecosystem services.

H.31 At the end of each day the current soil placement must be completed if rain is forecast. If during a day it is evident that a full strip cannot be completed, then only start part of a strip; this too must be completed.

H.32 At the end of each day, or during the day if interrupted by rain, make provisions to protect base of restored strip from ponding/runoff by sumps and grips, and also clean and level the basal layer. At the start of each day ensure there is no ponding in the current strip or operating areas, and the basal layer is to level with no ruts.

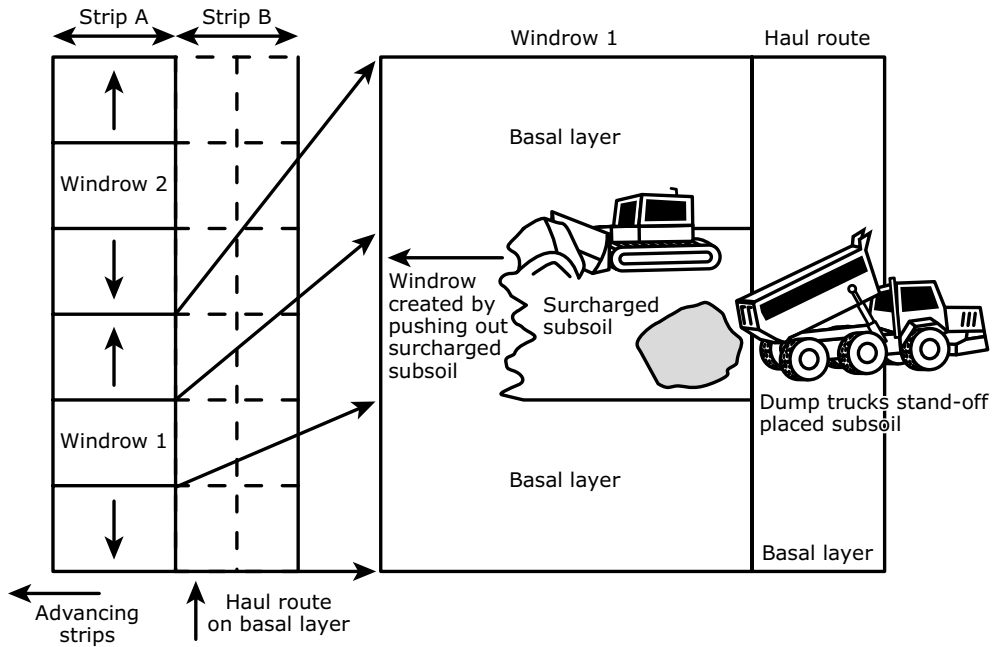

Figure H.1: Advance of subsoil surcharged windrow from dump trucks.

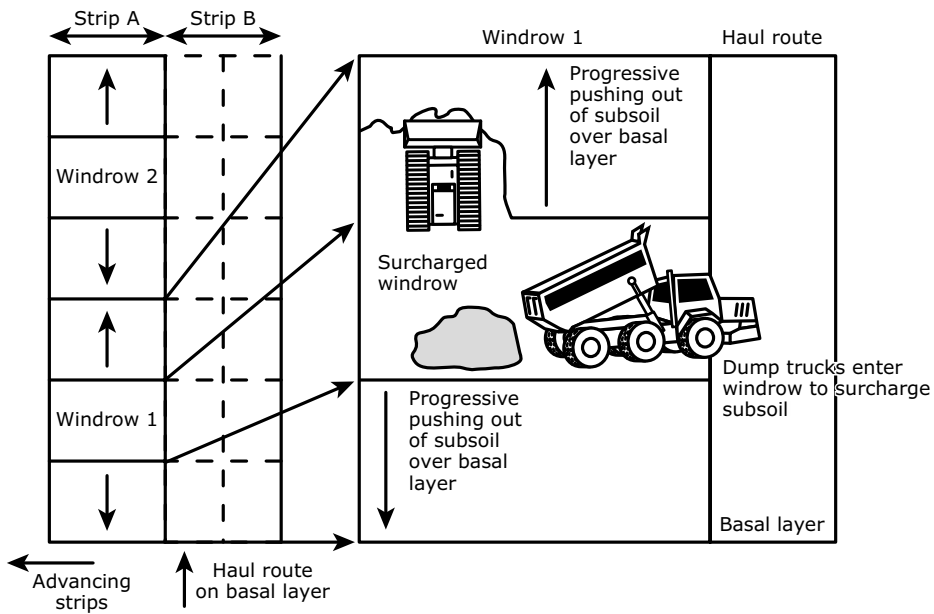

Figure H.2: Spreading of subsoil from surcharged windrow.

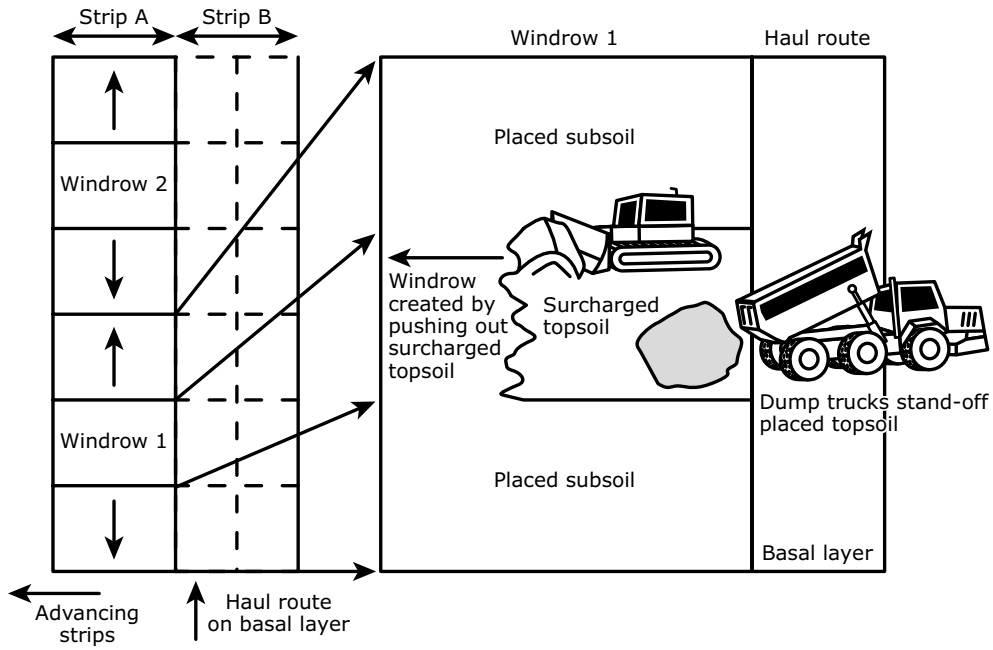

Figure H.3: Advance of topsoil surcharged windrow from dump trucks.

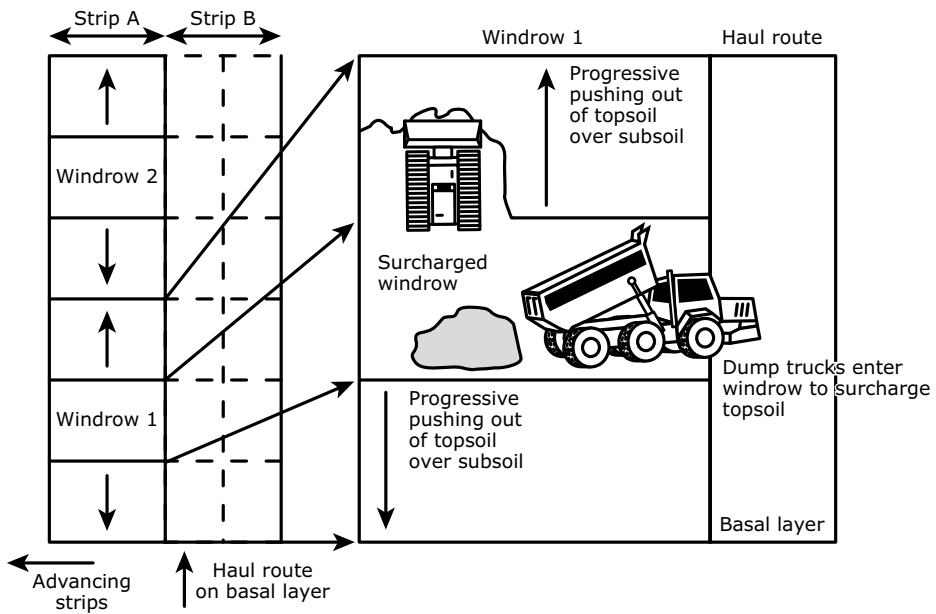

Figure H.4: Spreading of topsoil from surcharged windrow.

GOOD PRACTICE GUIDE FOR HANDLING SOILS

In Mineral Workings

PART TWO: Model Methodology

- Sheet I -

Soil Stripping with Bulldozers and Dump Trucks
- Modified Layer by Layer Practice

Author: Dr R N Humphries CBiol CSci FRSB FBSS FIQ
- Blakemere Consultants Ltd & Celtic Energy Ltd

Supporting artwork was provided by R Shelton (H J Banks & Co)
and D Fisher (Blue Room Graphics Ltd).

Preface

The purpose of Sheet I of the guidance is to provide a model method of best practice where bulldozers and dump trucks are to be used to strip soil using a modified soil layer by layer practice.

The guidance is intended for use by planning officials, statutory consultees, mineral operators and their supporting teams and specialist consultants, and earth-moving contractors, their site supervisors and machine operators.

Successful soil handling schemes are dependent on the soil resources being clearly identified and the conditions in which they are to be handled. This information should be contained in the Soil Resource & Management Plan (SRMP) and communicated to those involved in its implementation.

Key issues to be addressed are:

- i) Avoiding conditions when soils are wet/plastic during handling
- ii) The minimisation of soil compaction caused by trafficking and soil wetness
- iii) Using appropriate remedial treatments where these are necessary
- iv) Minimising soil loss, and mixing of soil layers or different soil types.

The SRMP should specify the type of earth-moving machinery and soil handling practice, and the soil wetness condition (see Part One of the Guidance) to be deployed to achieve the planned after use, soil functioning, and the environmental and ecosystem services. It is to be communicated in full to all involved and in particular to the supervisors and machine operators by appropriate means; including tool-box talks and site demonstrations. Supervision by trained supervisory staff is essential, as are monitoring and reporting.

The guidance does not specify the size or model of equipment as this is left to the mineral operator and contractor to specify and provide. The machines must be of a kind which are appropriate for the task and the outcomes required, and to be able to carry out the work safely and efficiently.

Should the agreed methodology need to be modified or changed significantly, this should be agreed in advance with the mineral planning authority. The SRMP should include a mechanism whereby unexpected less significant changes can be quickly resolved through consultation between the operator, the planning authority and statutory consultee, and soil specialist.

All persons involved in the handling of soils must comply with all relevant legislation with respect to Health and Safety, in particular the Health and Safety at work Act 1974 and in the case of mineral extraction operations, The Quarries Regulations 1999 and its relevant statutory provisions; in particular those aspects which relate to the construction and removal of tips, mounds and similar structures. These requirements take preference over any suggested practice in this Sheet and the SRMP should have taken these into account.

The users of this guidance are solely responsible for ensuring it complies with all safety legislation and good practice, including the manufacturer's specifications for the safe operation of the specific machines being used, and that all machines are in a good condition and well maintained and are suitable for the task. It is important that those involved in the operation of earth moving machines are competent and have the necessary training and certification.

Introduction

In the past soil layers have been stripped in their entirety one by one. Firstly the topsoil, then the subsoil layers by layer until the basal layer is exposed. The method deployed across the entire area is now discredited because of the likely severe compaction caused by the trafficking of the machines over much of the exposed soil surfaces. However, by restricting the extent of the ongoing process to blocks or wide bands of soil, to enable the dump trucks to travel on the basal layer, there may be instances where this ‘modified’ layer by layer approach can be deployed.

In this practice, only the bulldozer works on the exposed soil layers to form soil bunds along the exposed edge for loading by an excavator (usually) standing on the mound. This approach was described and illustrated in MAFF Sheet 13 <https://webarchive.nationalarchives.gov.uk/20090318025435/http://www.defra.gov.uk/farm/environment/land-use/soilguid/sheet13.pdf>.

It is also similar to the bulldozer practice described in **Sheet F**, but without the formation of windrows and the need for the excavator to traffic the surcharged soil to recover and load it into the dump trucks. In this respect it is easier to operate than the windrow practice and likely to cause less compaction.

The following modified guidance can also be adopted where only a single soil horizon is to be stripped.

Advantages & Disadvantages

The advantages of the modified handling practice are:

- i) It is very simple to administer requiring little supervision and skill
- ii) It can be quicker than both the excavator combination with the bed/strip and windrow practices
- iii) It offers flexibility in respect of short soil drying periods and likely wet weather as it is less susceptible to stoppages due to soil rewetting as a transpiring vegetation cover

can be retained later into the stripping programme. It is particularly suited to northerly and western, and upland locations, and particularly when there are uncertain weather patterns.

The disadvantages of the modified handling practice are:

- i) There is risk of compaction of the top- and subsoil layers by the repeated trafficking of the bulldozer, even if a low ground pressure machine is used, as it pushes soil to the windrows. Hence, subsequent remedial treatments are likely to be relied upon
- ii) It is slow react to localised changes in soil types and variation in horizon depth, and can result in the mixing of soil horizons
- iii) It is not suited to the stripping of thin and ‘patterned’ soil layers, and cleanly exposing the top-sub-soil interface.

Suitability

Neither the unmodified or modified practice are suitable for sites requiring archaeological investigations and reporting, or for ‘watching briefs’ during soil stripping.

The layer by layer handling practice, without modification, is not advisable for the conservation of soil resources and functioning. Whilst the modified method is not considered ‘best practice’, it may be acceptable in circumstances where:

- i) The subsoil(s) have a high resilience to further compaction (see **Part One**) and when decompaction treatments can be more relied upon to be effective because of a low risk of soil wetness (low rainfall areas/prolonged dry conditions) or operational limitations (such as the availability of effective decompaction tools)
- ii) The intended after use, and environmental and ecosystem services are less dependent on maintaining functional characteristics such as soil porosity and hence drainage and aeration, plant available water capacity, and low resistance to plant root growth. This may include low productivity agricultural and forestry land, some types of natural

habitats, and where water storage/infiltration is of lesser importance for the risk of flooding. Where the soils are stored prior to replacement, effective remedial treatment may have to be relied upon

iii) The soils are placed into storage stockpiles.

MODEL METHODOLOGY

I.1 Key operational points to minimise the risk of severe soil compaction and soil wetness with the modified layer by layer practice are summarised in Boxes I.1 and I.2.

Box I.1 - To minimise compaction:

- The dump trucks should normally only operate on the basal layer, and their wheels must not in any circumstances run on to the soil layer(s)
- The adoption of the strip by strip system minimises the need for the trucks to travel on the soil layers
- The machines are to only work when ground conditions enable their efficient operation
- The soils are to be stripped by the bulldozer in as thick layer as possible whilst maintaining their efficient operation
- The bulldozer should make the minimal number of passes over the soil as possible
- The soil layers are to be in 'dry' condition.

Box I.2 - To minimize the wetness of the soil and re-wetting of the soil:

- The modified strip by strip system provides a basis to regulate the exposure of lower soil layers to periods of rain and a means of maintaining soil moisture contents. The soil profile within the active strip should be stripped to the basal layer before rainfall occurs and before stripping is suspended.
- Measures are required to protect the face of the soil layer from ponding of water and maintain the basal layer in a condition capable of supporting dump trucks
- The area to be stripped is to be protected from in-flow of water, ponding etc. Wet sites should be drained in advance

- The maintenance of a transpiring crop is important, and an appropriate cropping regime should be established for the year of soil stripping
- Before stripping, excess vegetation should be removed; in the case of grassland it should be cut or grazed short and arable crops should have been harvested.

I.2 The timing of soil handling operations should only take place when the soils are in a 'dry and friable' condition (ie when it breaks and shatters when disturbed rather than smears and deforms) (see **Part One, Supplementary Note 4**). Prior to the start or recommencement of soil handling, they should be tested to confirm they are in suitably dry condition (see Box I.3).

I.3 Soil handling (by any machinery combination and handling practice) is not to take place during rain, sleet or snow and in these conditions should be prohibited due to unsafe machine operating conditions. Prior to commencing operations a medium/long term weather forecast should be obtained which gives reasonable confidence of soil handling being completed without significant interruptions from rainfall events. The soil based criteria set out in BOX I.4 are to be used to determine whether soil handling should cease or be interrupted with the occurrence of rain. The machines are to only work when ground conditions enable safe and efficient operation. Otherwise the operation is to be suspended until suitable remedial measures can be put in place.

I.5 The operation should follow the detailed stripping plan set out in the SRMP showing soil units to be stripped, haul routes and the phasing of vehicle movements. Different soil units to be kept separate are to be marked out and information to distinguish types and layers, and ranges of thickness needs to be conveyed to the operational supervisor/operator. The haul routes and soil storage areas must be defined and should be stripped first in a similar manner. Detailed daily records should be kept of operations undertaken, and site and soil conditions.

I.6 Demarcate an initial width of the 'strip' of soils to be recovered as the modified layer by layer practice.

Box I.3 - Test for Dry and Friable Soils

Soil tests are to be undertaken in the field. Samples shall be taken from at least five locations on the soil handling area and at each soil horizon to the full depth of the profile to be recovered/replaced. The tests shall include visual examination of the soil and physical assessment of soil consistency.

i) Examination

- If the soil is wet, films of water are visible on the surface of soil particles or aggregates (e.g. clods or peds) and/or when a clod or ped is squeezed in the hand it readily deforms into a cohesive 'ball' means **no soil handling to take place**
- If the sample is moist (i.e. there is a slight dampness when squeezed in the hand) but it does not significantly change colour (darken) on further wetting, and clods break up/crumble readily when squeezed in the hand rather than forming into a ball means **soil handling can take place**
- If the sample is dry, it looks dry and changes colour (darkens) if water is added, and it is brittle means **soil handling can take place**

ii) Consistency**First Test**

Attempt to mould soil sample into a ball by hand:

- Impossible because soil is too dry and hard or too loose and dry means soil handling can take place
- Impossible because the soil is too loose and wet means no soil handling to take place
- Possible - GO TO SECOND TEST

Second Test

Attempt to roll ball into a 3mm diameter thread by hand:

- Impossible because soil crumbles or collapses means **soil handling can take place**
- Possible means **no soil handling to take place**

NB: It is impossible to roll most coarse loamy and sandy soils into a thread even when they are wet. For these soils, the Examination Test alone is to be used.

Box I.4 – Rainfall Criteria:

- In light drizzle soil handling may continue for up to four hours unless the soils are already at/near to their moisture limit
- In light rain soil handling must cease after 15 minutes
- In heavy rain and intense showers, handling shall cease immediately.

In all of the above, after rain has ceased, soil tests shall be applied to determine whether handling may re-start, provided that the ground is free from ponding and ground conditions are safe to do so.

Box I.5

Whilst there can be a lower of a risk of compaction when using wide tracked ('low ground pressure' (LGP)) bulldozers, in some circumstances they may require to traffic the soil surface more than standard machines to achieve the same work rate, and therefore the advantage of their use may be less than anticipated. However, the risk of severe compaction and reliance on remedial treatments may be less with the use of LGP machines.

This is the effective push distance of the bulldozer to bund the soil at the edge of the strip (Box I.5).

I.7 Within each soil unit the soil layers above the base/formation layer are to be stripped layer by layer in the retreating strips/blocks until all the soil is removed (**Figure I.1**).

I.8 The bulldozer is only to stand and work on the soil layer when stripping soils and the excavator on the resulting soil mound, otherwise they are to travel only on the basal/formation layer. The dump trucks are to operate only on the basal layer (**Figure I.2**).

I.9 The topsoil is to be pushed towards the retreating edge and heaped for the excavator to load onto the dump trucks (**Figure I.2**). The topsoil should be recovered to the full width of the segment without mixing with subsoil (not more than 20% of the lower horizon should be exposed at the layer junction within the strip). The thickness and identification of the horizon junction must be verified before and

during stripping. The procedure is repeated until all of the topsoil has been removed.

I.10 The above procedure is then repeated for the sub-soil until all the soil layer has been recovered, and then any subsequent lower layer to be recovered until the basal layer is fully exposed (**Figure I.3**).

I.11 Where the soils are to be directly replaced without storage in mounds, the initial strip of the upper horizons will have to be stored temporarily to release the lowest layer and enable the sequential movement of materials. The stored initial soil material would be placed on the lower layer removed from the final strip at the end of the programme or on partially completed profiles if rain was forecast.

I.12 Where the stripping operation is likely to be interrupted by rain or there is likely to be overnight rain, the soil layer is to be 'sealed' by the bulldozer tracking and 'blading' the exposed surface. Make provisions to protect base of current or next strip from ponding/runoff by sumps and grips, and also clean and level the basal layer. At the start of each day ensure there is no ponding in the current strip or operating areas, and the basal layer is to level with no ruts.

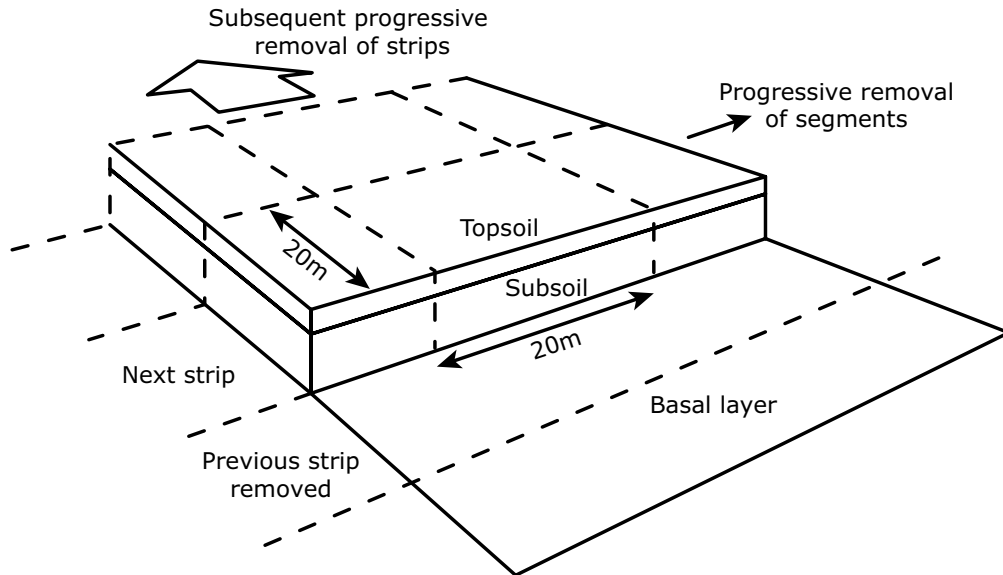

Figure I.1: Soil stripping with bulldozers and dump trucks using modified layer by layer practice.

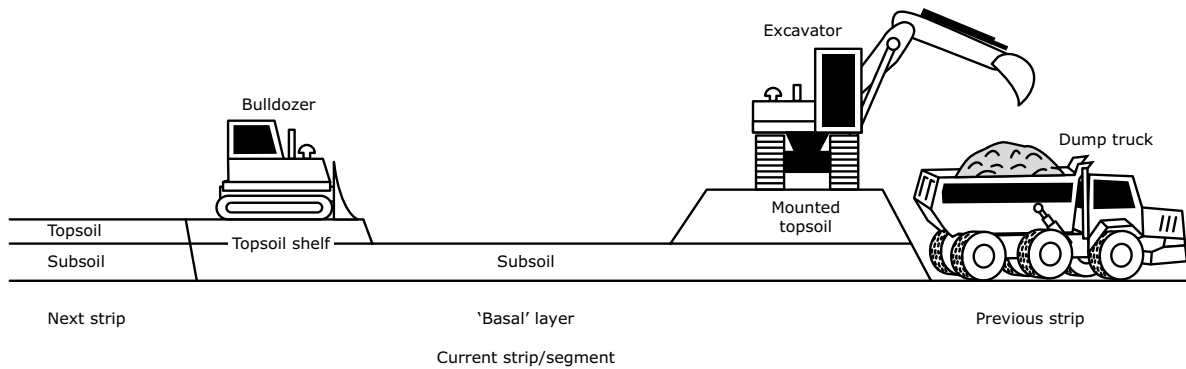

Figure I.2: Soil stripping with bulldozers and dump trucks using modified layer by layer method: Topsoil.

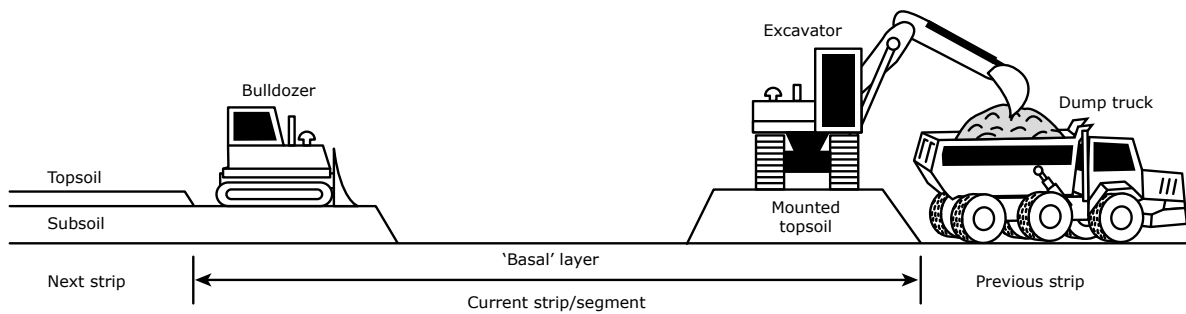

Figure I.3: Soil stripping with bulldozers and dump trucks using modified layer by layer method: Subsoil.

GOOD PRACTICE GUIDE FOR HANDLING SOILS

In Mineral Workings

PART TWO: Model Methodology

- Sheet J -

Soil Replacement with Bulldozers and Dump Trucks
- Modified Layer by Layer Practice

Author: Dr R N Humphries CBiol CSci FRSB FBSS FIQ
- Blakemere Consultants Ltd & Celtic Energy Ltd

Supporting artwork was provided by R Shelton (H J Banks & Co)
and D Fisher (Blue Room Graphics Ltd).

Preface

The purpose of Part Two, Sheet J of the guidance is to provide a model method of best practice where bulldozers and dump trucks are to be used to replace soil using the modified layer by layer practice.

The guidance is intended for use by planning officials, statutory consultees, mineral operators and their supporting teams and specialist consultants, and earth-moving contractors, their site supervisors and machine operators.

Successful soil handling schemes are dependent on the soil resources being clearly identified and the conditions in which they are to be handled. This information should be contained in the Soil Resource & Management Plan (SRMP) and communicated to those involved in its implementation.

Key issues to be addressed are:

- i) Avoiding conditions when soils are wet/plastic during handling
- ii) The minimisation of soil compaction caused by trafficking and soil wetness
- iii) Using appropriate remedial treatments where these are necessary
- iv) Minimising soil loss, and mixing of soil layers or different soil types.

The SRMP should specify the type of earth-moving machinery and soil handling practice, and the soil wetness condition (see Part One of the Guidance) to be deployed to achieve the planned after use, soil functioning, and the environmental and ecosystem services. It is to be communicated in full to all involved and in particular to the supervisors and machine operators by appropriate means; including tool-box talks and site demonstrations. Supervision by trained supervisory staff is essential, as are monitoring and reporting.

The guidance does not specify the size or model of equipment as this is left to the mineral operator and contractor to specify and provide. The machines must be of a kind which are appropriate for the task and the outcomes required, and to be able to carry out the work safely and efficiently.

Should the agreed methodology need to be modified or changed significantly, this should be agreed in advance with the mineral planning authority. The SRMP should include a mechanism whereby unexpected less significant changes can be quickly resolved through consultation between the operator, the planning authority and statutory consultee, and soil specialist.

All persons involved in the handling of soils must comply with all relevant legislation with respect to Health and Safety, in particular the Health and Safety at work Act 1974 and in the case of mineral extraction operations, The Quarries Regulations 1999 and its relevant statutory provisions; in particular those aspects which relate to the construction and removal of tips, mounds and similar structures. These requirements take preference over any suggested practice in this Sheet and the SRMP should have taken these into account.

The users of this guidance are solely responsible for ensuring it complies with all safety legislation and good practice, including the manufacturer's specifications for the safe operation of the specific machines being used, and that all machines are in a good condition and well maintained and are suitable for the task. It is important that those involved in the operation of earth moving machines are competent and have the necessary training and certification.

Introduction

In the past soil layers have been replaced in their entirety one by one. Firstly the subsoil, then the topsoil layer until the basal layer is covered. The method deployed across the entire area is now discredited because of the likely severe compaction caused by the trafficking of the machines over much of the exposed soil surfaces. However, by restricting the extent of the ongoing process to blocks or wide bands of soil, to enable the dump trucks to travel on the basal layer, there may be instances where this ‘modified’ layer by layer approach can be deployed.

In this practice, only the bulldozer works on the exposed soil layers and pushes out the soil from bunds tipped by the dump trucks along the advancing soil edge. This approach was described and illustrated in MAFF Sheet 15 <https://webarchive.nationalarchives.gov.uk/ukgwa/20090318025517/http://www.defra.gov.uk/farm/environment/land-use/soilguid/sheet15.pdf>. It is also similar to the bulldozer practice given in **Sheet H**, but without the formation of windrows and the need for the dump truck to traffic the surcharged soil. In this respect it is easier to operate than the windrow practice and likely to cause less compaction.

The following guidance can be adopted where only a single topsoil horizon is to be placed.

Advantages & Disadvantages

The advantages of the modified handling practice are:

- i) It is very simple to administer requiring little supervision and skill
- ii) It can be quicker than both the excavator combination with the bed/strip and windrow practices
- iii) It offers flexibility in respect of short dry periods and likely wet weather as it is less susceptible to stoppages due to soil rewetting and a vegetation cover can be sequentially established.

The disadvantages of the modified handling practice are:

- i) There is risk of compaction of the top- and subsoil layers by the repeated trafficking of the bulldozer, even if a low ground pressure machine is used, as it pushes out the soil. Hence, subsequent remedial treatments are likely to be relied upon
- ii) It is not suited to the laying of thin and ‘patterned’ soil layers.

Suitability

The layer by layer handling practice, without modification, is not advisable for the conservation of soil resources and functioning. Whilst the modified method is not considered ‘best practice’, it may be acceptable in circumstances where:

- i) The subsoil(s) have a high resilience to further compaction (see **Table 7, Part One**) and when decompaction treatments can be more relied upon to be effective because of a low risk of soil wetness (low rainfall areas/ prolonged dry conditions) or operational limitations (such as the availability of effective decompaction tools)
- ii) The intended after use, and environmental and ecosystem services are less dependent on maintaining functional characteristics such as soil porosity and hence drainage and aeration, plant available water capacity, and low resistance to plant root growth. This may include low productivity agricultural and forestry land, some types of natural habitats, and where water storage/infiltration is of lesser importance for the risk of flooding. Where the soils are stored prior to replacement, effective remedial treatment may have to be relied upon
- iii) The soils have been placed into storage stockpiles
- iv) It is suited to northern and western, and upland locations, and particularly when there are uncertain weather patterns.

MODEL METHODOLOGY

Basic Replacement Operation

The following is the basic model methodology using bulldozers with dump trucks and the modified layer by layer practice. It is presented here, firstly without any remedial interventions to give clarity of the methodology. Further on the methodology is repeated with the interventions to demonstrate how integration is to be achieved.

Box J.1 - To minimize compaction:

- The dump trucks should only operate on the 'basal'/non-soil layer, and their wheels must not in any circumstances run on to the soil layer(s)
- The machines are to only work when ground conditions enable their efficient operation
- The soils are to be replaced by the bulldozer in as thick layer as possible whilst maintaining their operational efficiency
- The bulldozer should make the minimal number of passes over the soil as possible
- The soil layers are to be in 'dry' condition.

Box J.2 - To minimize the wetness of the soil and re-wetting of the soil:

- Measures are required to protect the face of the soil layer from ponding of water and maintain the basal layer in a condition capable of supporting dump trucks.
- The area to be replaced is to be protected from in-flow of water, ponding etc. Wet sites should be drained in advance.

J.1 Key operational points to minimize the risk of severe soil compaction and soil wetness are summarised in Boxes J.1 and J.2.

J.2 The timing of soil handling operations in England and Wales is set out in **Part One, Supplementary Note 4**. For directly placed soils this will use the in situ soil wetness protocol for soil stripping operations to determine the timing for soil replacement (Box J.3). For soil that has been stored, the relaying operation should be governed by the

Box J.3 - Test for Dry and Friable Soils

Soil tests are to be undertaken in the field. Samples shall be taken from at least five locations on the soil handling area and at each soil horizon to the full depth of the profile to be recovered/replaced. The tests shall include visual examination of the soil and physical assessment of soil consistency.

i) Examination

- If the soil is wet, films of water are visible on the surface of soil particles or aggregates (e.g. clods or peds) and/or when a clod or ped is squeezed in the hand it readily deforms into a cohesive 'ball' means **no soil handling to take place**
- If the sample is moist (i.e. there is a slight dampness when squeezed in the hand) but it does not significantly change colour (darken) on further wetting, and clods break up/crumble readily when squeezed in the hand rather than forming into a ball means **soil handling can take place**
- If the sample is dry, it looks dry and changes colour (darkens) if water is added, and it is brittle means **soil handling can take place**

ii) Consistency

First Test

Attempt to mould soil sample into a ball by hand:

- Impossible because soil is too dry and hard or too loose and dry means soil handling can take place
- Impossible because the soil is too loose and wet means no soil handling to take place
- Possible - GO TO SECOND TEST

Second Test

Attempt to roll ball into a 3mm diameter thread by hand:

- Impossible because soil crumbles or collapses means **soil handling can take place**
- Possible means **no soil handling to take place**

NB: It is impossible to roll most coarse loamy and sandy soils into a thread even when they are wet. For these soils, the Examination Test alone is to be used.

weather (rainfall) criteria set out in Box J.4. Here, the operation will generally need to be completed no later than the end of September unless the establishment of a satisfactory vegetation cover can be assured.

J.3 Soil handling is not to take place during rain, sleet or snow and in these conditions should be prohibited if unsafe for machine operations. Prior to commencing operations, a medium/long term weather forecast should be obtained which gives reasonable confidence of soil handling being completed without significant interruptions from rainfall events. The criteria set out in Box J.3 are to be used to determine whether soil handling should cease or be interrupted with the occurrence of rain.

J.4 All machines must be in a safe and efficient working condition at all times. The machines are only to work when ground conditions enable their efficient operation. The work should only be carried out when the basal layer supports the machinery without ruts or is capable of repair/maintenance. Otherwise the operation is to be suspended until suitable remedial measures can be put in place.

Box J.4 - Rainfall Criteria:

- In light drizzle soil handling may continue for up to four hours unless the soils are already at/near to their moisture limit
- In light rain soil handling must cease after 15 minutes
- In heavy rain and intense showers, handling shall cease immediately.

In all of the above, after rain has ceased, soil tests shall be applied to determine whether handling may re-start, provided that the ground is free from ponding and ground conditions are safe to do so.

J.5 The operation should follow the detailed soil plan set out in the SRMP showing soil units to be replaced, haul routes and the phasing of vehicle movements. Different soil units to be kept separate are to be marked out and information to distinguish types and layers, and ranges of thickness needs to be conveyed to the operational supervisor/operator. The haul routes and soil storage areas must be defined and should be replaced in a similar manner.

Detailed daily records should be kept of operations undertaken, and site and soil conditions.

Box J.5

Whilst there can be a lower of a risk of compaction when using wide tracked ('low ground pressure' (LGP)) bulldozers, in some circumstances they may require to traffic the soil surface more than standard machines to achieve the same work rate, and therefore the advantage of their use may be less than anticipated. However, the risk of severe compaction and reliance on remedial treatments may be less with the use of LGP machines.

J.6 Within each soil unit the soil layers above the base/formation layer are to be replaced using a bulldozer to spread the soil layer by layer in advancing strips/blocks until all the soil is replaced. The bulldozer is only to stand and work on the soil layer when replacing the soils, otherwise it is to travel only on the basal layer. The dump trucks in this practice only operate on the basal layer.

Box J.6 - Soil Profiles Greater Than 1m Thickness

When the replaced soil profiles reach about 1m in height from the basal layer it may not be possible to discharge the load from smaller dump trucks directly onto the previously placed lower layers because of the height of the dump truck body. The preferred solution is to tip the soil against the partially completed profile as heaps without the dump trucks rising onto or reversing into the placed material. The soil material is then lifted by the excavator onto the profile. It is considered preferable to accept some limited soil losses rather than to contaminate the topsoil with overburden. The loss of top-soil is minimised if the basal/formation layer is kept to level and clean.

J.7 Demarcate the width of the strip to be soiled and the width of the replaced soil strip is the effective push distance of the bulldozer (Box J.5). Profile boards should be used to control soil horizon thickness being replaced and overall levels achieved verified using soil pits.

J.7 The dump truck tips the soil load on the front of the advancing face and the bulldozer pushes out the tipped subsoil to its full and final thickness with the minimum distance and number of pushes (**Figures J.1 & J.2**). The procedure is repeated until the strip of the subsoil layer is replaced.

Box J.7 - Integration of Decompaction & Stone/Debris Removal

Option 1: is where the basal layer needs to be treated but is left until the subsoil is placed when both are decompacted together, followed by the decompaction of the topsoil and subsoil layers together (and basal layer) using tines that are long enough. This option is not suited to digging where the soil horizons would be mixed.

Option 2: is where each layer is treated separately by either tines or digging.

Option 3: is where the basal layer is treated or left untreated, followed by the placement of the subsoil and topsoil layers, which are to be decompacted by the use of tines. In the case of deep horizons this option can be limited by the capability of the machinery, the tines or bucket used. This option is not suited to digging where the soil horizons would be mixed.

J.8 On completion of the width of the subsoil strip/block, the topsoil is tipped on its leading edge and pushed out to the final thickness with the minimum number of pushes (**Figure J.3**). This is repeated to advance topsoil coverage until the entire strip is soiled (see Box J.6 where soil profile is greater than 1m thickness).

J.9 Where the replacement operation is likely to be interrupted by rain, the topsoil layer should be placed before rain occurs and at the end of each day. Should this not be possible the subsoil layer is

to be 'sealed' by a low ground pressure bulldozer tracking and 'blading' of the exposed surface. Make provisions to protect base of current or next strip from ponding/runoff by sumps and grips, and also clean and level the basal layer. At the start of each day ensure there is no ponding in the current strip or operating areas, and the basal layer is to level with no ruts.

Methodology with Remedial Actions

J.10 The following is the model methodology using bulldozers with dump trucks and the modified layer by layer practice with the remedial interventions to demonstrate how integration is to be achieved. The key operational points to minimize the risk of severe soil compaction and soil wetness are summarised in Boxes J.1 and J.2 above.

J.11 Usually there will be a need for decompaction treatment during the replacement operation with this methodology. The placement of the stripped soils in storage is likely to result in greater compaction. Where compaction occurs, treatment will need integrating into the replacement process as will any need for the removal of stones or non-soil debris. Both decompaction and removal of materials are covered in separate **Sheets L to O**.

J.12 Box J.7 sets out some of the remedial options/combinations to facilitate removal of stones and decompaction.

J.13 Prior to work commencing a weather forecast should be obtained which gives reasonable confidence of soil replacement proceeding without interruptions from rainfall events (see Box J.4).

J.14 If significant rainfall occurs during operations, the replacement must be suspended, and where the soil profile has been started it should be replaced to the topsoil level. Replacement must not restart unless the weather forecast is expected to be dry for at least a full day and the soils are in a dry condition (see above Box J.3).

J.15 All machines must be in a safe and efficient working condition at all times. The machines are only to work when ground conditions enable their efficient operation. The work should only be carried

out when the basal layer supports the machinery without ruts or is capable of repair/maintenance. Otherwise the operation is to be suspended until suitable remedial measures can be put in place.

J.16 The operation should follow the detailed replacement plan in the SRMP showing the soil units to be replaced, haul routes and the phasing of vehicle movements. The soil units should be defined on the site with information to distinguish types and layers, and thickness and conveyed to the operational supervisor/operator. Different soil units to be kept separate are to be marked out and information to distinguish types and layers, and ranges of thickness needs to be conveyed to the operational supervisor/operator. Detailed daily records should be kept of operations undertaken and site and soil conditions (including the removal of stones and other non-soil debris that needs to be removed), and the results of the effectiveness of the work undertaken, and any need for additional remedial treatments.

J.17 Within each soil unit the soil layers above the base/formation layer are to be replaced layer by layer in advancing strips until all the soil is replaced. The haul routes and storage areas must be defined and should be replaced last in a similar manner.

J.18 Profile boards should be used to control soil horizon thickness being replaced and overall levels achieved verified using soil pits. Allowances (ie. bulking factor) should be made for any 'heave' that may take place when the replaced soil is decompacted.

J.19 Only the bulldozer is to stand and work on the soil layer when replacing the soils, otherwise it is to travel on the basal layer.

J.20 Where there is a requirement to treat compaction and/or remove stones/non-soil debris in the basal layer, these need to be carried out prior to the first layer of soils being laid. Decompaction can be done by digging with the excavator bucket or by bulldozer drawn tines (**Sheets N & O**). Stone removal may require prior ripping/digging to release them from the soil, followed by the excavator using a stone-rake bucket (to be loaded on a dump truck and removed)

(**Sheets L & M**).

Where these treatments are deployed, to minimise additional compaction/recompaction, only the bulldozer need to work and traffic the basal layer and the soil surfaces, and the excavator and the dump truck being loaded with the recovered stones/debris stand and travel on the untreated basal layer.

J.21 On completion of the remedial work, the subsoil is spread with the bulldozer pushing out the soil, tipped at the edge of the treated basal layer to cover it to the required depth (**Figures J.1 & J.2**). The dump trucks should avoid reversing onto the treated basal layer to minimize severe recompaction of the basal layer.

J.22 On completion of the subsoil placement and where there is a requirement to treat compaction and/or remove stones and non-soil debris in the subsoil, these need to be carried out prior to the topsoil layer of soil being laid. Decompaction can be done by digging with the excavator bucket or by bulldozer drawn tines (**Sheets N & O**). Stone removal may require prior ripping/digging to release them from the subsoil, followed by the excavator using a stone-rake bucket (**Sheets L & M**). Where these treatments are deployed, to minimise additional compaction/recompaction, only the bulldozer need to work and traffic the subsoil layer, and the excavator and the dump truck being loaded with the recovered stones/debris stand and travel on the untreated basal layer.

J.23 On completion of the subsoil remediation works the topsoil replacement begins. The dump truck tip the topsoil on to the advancing edge of the subsoiled strip (see also Box J.6) for the bulldozer to push out to its final thickness with the minimum distance and number of pushes (**Figure J.3**). The procedure is repeated across the area to be soiled until it is completed.

J.24 Where there is a requirement to treat compaction and/or remove stones and non-soil debris in the topsoil, decompaction can be done by digging with the excavator bucket or by bulldozer drawn tines (**Sheets N & O**).

Stone removal may require prior ripping/digging to release them from the topsoil, followed by the excavator using a stone-rake bucket (to be loaded on a dump truck and removed) (**Sheets L & M**). Where these treatments are deployed, to minimise additional compaction/recompaction, only the bulldozer need to work and traffic the topsoil, and the excavator and the dump truck being loaded with the recovered stones/debris stand and travel on the untreated basal layer.

J.25 Whilst remedial treatment is generally limited to the bulldozer option (**Sheets M & O**), because of the risk of further compaction from the excavator and dump truck option (**Sheets L & N**), it is possible to arrange for the operations so that there is minimal trafficking and the retreating excavator treats any compacted areas.

J.26 There is also the option of ripping with bulldozer tines (**Sheet O**) to treat compaction in the top- and subsoil layers together (Box J.7, Option 3). Here, stone and non-soil debris removal would be restricted to the topsoil layer. However, this Option is only advisable where it is certain that it will be effective.

J.27 On completion of the replacement of the full soil profile in the strip, the next is formed with the process being repeated until the area to be soiled has been completed.

J.28 Where the replacement operation is likely to be interrupted by rain or there is likely to be overnight rain, the exposed subsoil and topsoil layers are to be 'sealed' by the bulldozer tracking and 'blading' the exposed surface. Make provisions to protect base of current or next strip from ponding/runoff by sumps and grips, and also clean and level the basal layer. At the start of each day ensure there is no ponding in the current strip or operating areas, and the basal layer is to level with no ruts.

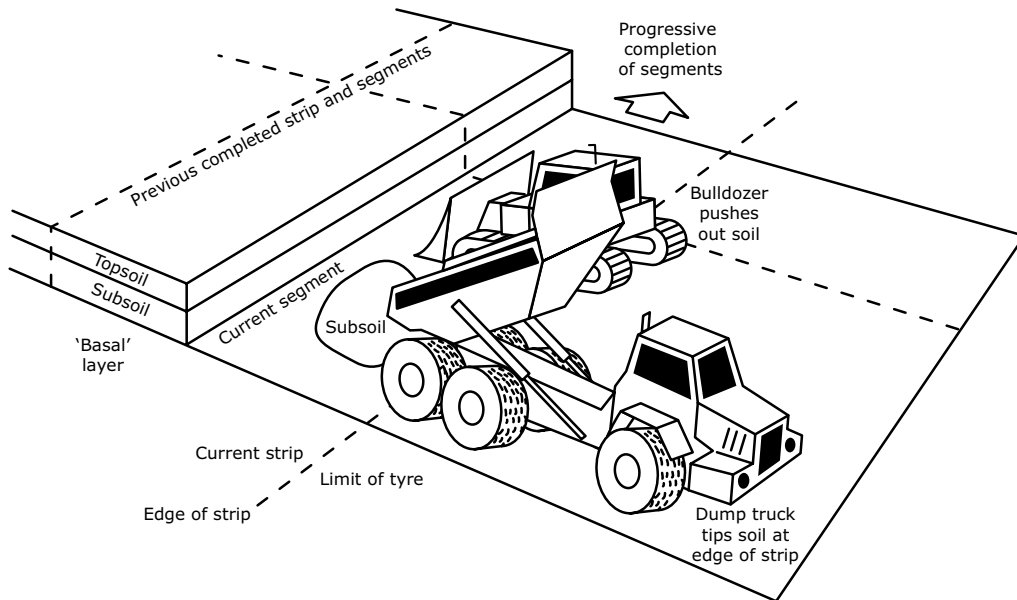

Figure J.1: Soil replacement with bulldozer and dump truck using modified layer by layer method: Subsoil.

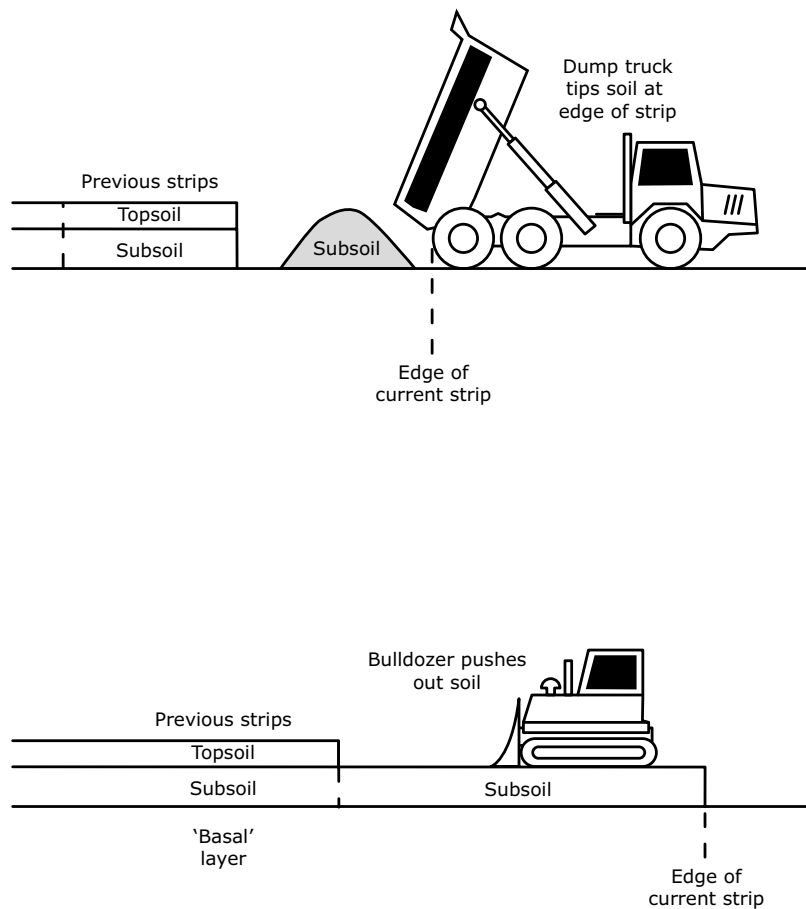

Figure J.2: Soil replacement with bulldozers and dump trucks using modified layer by layer method: Subsoil.

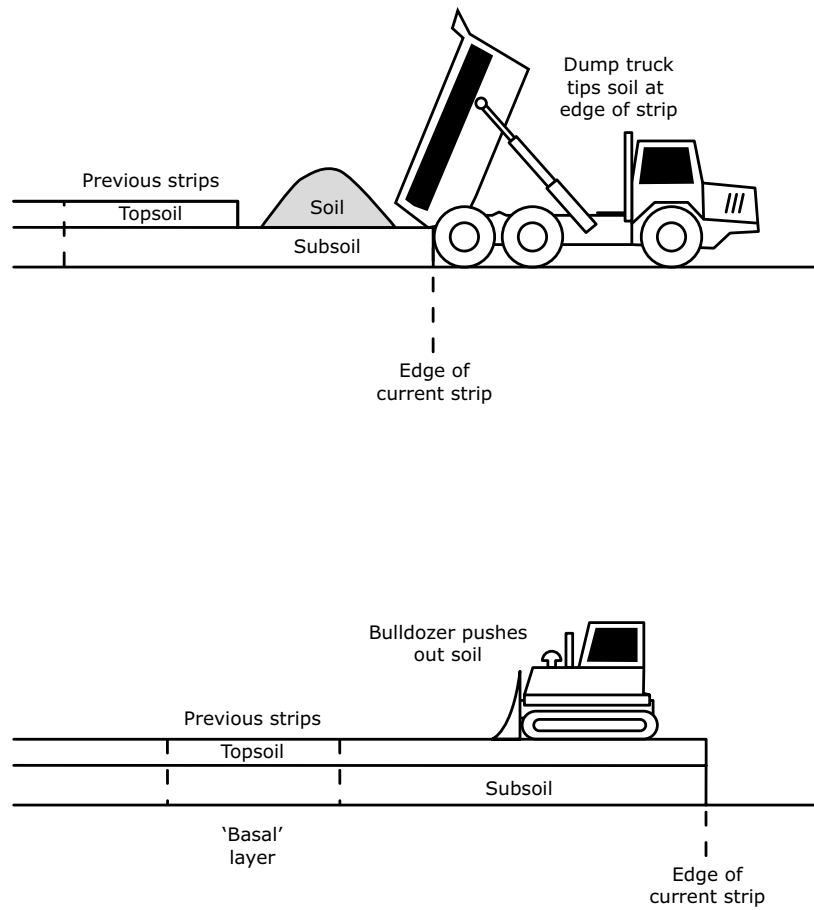

Figure J.3: Soil replacement with bulldozers and dump trucks using modified layer by layer method: Topsoil.

GOOD PRACTICE GUIDE FOR HANDLING SOILS

In Mineral Workings

PART TWO: Model Methodology

- Sheet K -

Hybrid Soil Replacement with Excavators, Bulldozers and Dump Trucks
- Modified Layer by Layer Practice

Author: Dr R N Humphries CBiol CSci FRSB FBSSS FIQ
- Blakemere Consultants Ltd & Celtic Energy Ltd

Supporting artwork was provided by R Shelton (H J Banks & Co)
and D Fisher (Blue Room Graphics Ltd).

Preface

The purpose of Sheet K of the guidance is to provide a model method of best practice where the hybrid combination of excavator and bulldozer with dump trucks are to be used to replace soil using the modified 'layer by layer' practice.

The guidance is intended for use by planning officials, statutory consultees, mineral operators and their supporting teams and specialist consultants, and earth-moving contractors, their site supervisors and machine operators.

Successful soil handling schemes are dependent on the soil resources being clearly identified and the conditions in which they are to be handled. This information should be contained in the Soil Resource & Management Plan (SRMP) and communicated to those involved in its implementation.

Key issues to be addressed are:

- i) Avoiding conditions when soils are wet/plastic during handling
- ii) The minimisation of soil compaction caused by trafficking and soil wetness
- iii) Using appropriate remedial treatments where these are necessary
- iv) Minimising soil loss, and mixing of soil layers or different soil types.

The SRMP should specify the type of earth-moving machinery and soil handling practice, and the soil wetness condition (see Part One of the Guidance) to be deployed to achieve the planned after use, soil functioning, and the environmental and ecosystem services. It is to be communicated in full to all involved and in particular to the supervisors and machine operators by appropriate means; including tool-box talks and site demonstrations. Supervision by trained supervisory staff is essential, as are monitoring and reporting.

The guidance does not specify the size or model of equipment as this is left to the mineral operator and contractor to specify and provide. The machines must be of a kind which are appropriate for the task and the outcomes required, and to be able to carry

out the work safely and efficiently.

Should the agreed methodology need to be modified or changed significantly, this should be agreed in advance with the mineral planning authority. The SRMP should include a mechanism whereby unexpected less significant changes can be quickly resolved through consultation between the operator, the planning authority and statutory consultee, and soil specialist.

All persons involved in the handling of soils must comply with all relevant legislation with respect to Health and Safety, in particular the Health and Safety at work Act 1974 and in the case of mineral extraction operations, The Quarries Regulations 1999 and its relevant statutory provisions; in particular those aspects which relate to the construction and removal of tips, mounds and similar structures. These requirements take preference over any suggested practice in this Sheet and the SRMP should have taken these into account.

The users of this guidance are solely responsible for ensuring it complies with all safety legislation and good practice, including the manufacturer's specifications for the safe operation of the specific machines being used, and that all machines are in a good condition and well maintained and are suitable for the task. It is important that those involved in the operation of earth moving machines are competent and have the necessary training and certification.

Introduction

In this soil handling option, back-acting excavators are used to replace the subsoil resources tipped from dump trucks and, specifically low ground pressure bulldozers, are used to spread the topsoil layer. It is referred to as a version of loose soil tipping in [DEFRA's Construction Code of Practice for the Sustainable Use of Soils on Construction Sites](#).

The practice involves the sequential building up of the soil layer(s) identified in the Soil Resource & Management Plan (SRMP) using an excavator to spread the subsoil to final level and a bulldozer to spread the topsoil.

The subsoil is placed first as a series of advancing strips within the safe and efficient operational reach of the excavator boom which defines the width of each successive subsoil strip. On the completion of each subsoil strip before the next is soiled, the topsoil is tipped onto the subsoil for spreading by the bulldozer later.

This method differs from the standard excavator method (Sheet D) in that the topsoil is spread by a bulldozer and over a layer of subsoil.

The procedure for spreading of the topsoil is similar to the practice set out in [MAFF 2000, Sheet 15](#).

It is a preferable practice to the bulldozer windrow/peninsular method set out in Sheet H as the dump trucks do not traffic the topsoil and risk causing additional severe compaction.

Unlike the stripping and storage practices, the replacement of soils is usually in concert with other work to remediate soil conditions such as compaction (**Sheets N & O**) and removal of stones/non-soil debris (**Sheets L & M**). These actions have their own practices which need to be integrated into this model methodology of soil handling. The need for these will have been specified in the SRMP and/or in the soil replacement conditions attached to the planning consent, or as determined by the soil specialist during the soil stripping/storage/replacement operations.

The following guidance is only relevant to multiple layered soils.

Advantages & Disadvantages

The advantages of this machinery combination and handling practice are several:

- i) Provided the soils are not put into storage mounds, it may result in soil profiles with the less compacted (upper) subsoils which may not require remedial treatment or only minimal of action
- ii) It can be easy to create localised changes in subsoil types and variation in horizon depth
- iii) It is likely to result in less soil loss and mixing than the excavator only practice
- iv) The layer by layer system may be quicker to complete than the bed/strip only practice, provided that remedial treatments are not required of the subsoil
- v) It can be moderately flexible in responding to stoppages and restarts due to wet weather
- vi) There is some certainty that a transpiring vegetation cover can be established during the soil replacement programme.

The disadvantages are several:

- i) The deployment of two different handling methods requires a high level of supervision, skill and discipline in its deployment, and is best suited to experienced operators
- ii) There is risk of compaction of the top- and upper subsoil layers by the repeated trafficking of the bulldozer, even if a low ground pressure machine is used. Hence, subsequent remedial treatments are likely to be relied upon
- iii) It is slower than both the excavator combination with the bed/strip and windrow practices because of the dual handling practices
- iv) Without good control and regular monitoring of soil layer depths, use of profile boards or machine fitted GPS it can be harder to gauge the rate of use of subsoil resource
- v) It is not suited both to the replacement of low bearing strength soils (eg peat & organic topsoil), and thin and 'patterned' topsoil layers
- vi) Where remedial work is relied upon, the

- sequential tipping of topsoil and the laying of the next subsoil strip will have to be delayed until the strip in question is treated
- vii) Steep gradient/complex topographies may limit the safe and practical deployment of this handling practice.

- replacement, effective remedial treatment may have to be relied upon
- iv) The soils have been placed into storage stockpiles
- v) It is more suited to southern and eastern, and lowland locations, and particularly when there are the more certain weather patterns.

Suitability

The hybrid excavator-bulldozer and dump truck combination with the modified layer by layer handling practice methodology is considered by DEFRA as an acceptable alternative practice to loose tipping. However, there is a risk of compaction in the topsoil layer and in the underlying (upper) subsoil, and the implementation of remedial treatments may be restrictive. As it is more reliant on remedial treatment than the standard excavator method (**Sheet D**), it is also more dependent on the soils being in a dry condition. Because of this it is considered only suitable for medium and highly resilient soils (see **Table 7 in Part One and Supplementary Notes 3 & 4**), and should not be considered an alternative to the excavator only practice (**Sheet D**) without justifiable reasons.

Whilst the hybrid method is not considered to be the 'best practice', it may be acceptable in circumstances where

- i) The subsoil(s) are of medium to high resilience to compaction (see **Table 7 in Part One, and Supplementary Notes 3 & 4**) and when decompaction treatments can be more relied upon to be effective because of i) a lower risk of soil wetness (low rainfall areas/prolonged dry conditions) and/or ii) the availability of effective decompaction tools
- ii) The limitations of compaction and stones/debris is restricted to the topsoil layer
- iii) The intended after use, and environmental and ecosystem services are less dependent on maintaining functional characteristics such as soil porosity and hence drainage and aeration, plant available water capacity, and low resistance to plant root growth. This may include the less productivity agricultural and forestry land, some types of natural habitats, and where water storage/infiltration is of less importance for the risk of flooding. Where the soils are stored prior to

MODEL METHODOLOGY

Basic Soil Replacement Operation

K.1 The following is the basic model methodology using the hybrid method of excavators, bulldozers and dump trucks with a modified layer by layer practice. It is presented here, firstly without any remedial interventions to give clarity of the methodology. Later the methodology is repeated to demonstrate how the interventions can be integrated into the soil replacement process.

K.2 Key operational points to minimise the risk of severe soil compaction and soil wetness are summarised in Boxes K.1 and K.2.

Box K.1 - To minimize compaction:

- The bulldozer is to only operate on the topsoil
- The dump trucks should only operate on the 'basal'/non-soil layer and not run on the replaced soil layer(s)
- The excavator must only operate on the basal layer
- The machines are to only work when ground conditions enable their efficient operation
- The bulldozer should make the minimal number of passes over the soil as possible
- If compaction has been caused, then measures are required to treat it (see **Sheets N & O**)

Box K.2 - To minimise soil wetness and re-wetting:

- The modified layer by layer system provides a basis to regulate the exposure of lower soil layers to periods of rain and a means of maintaining soil moisture contents. The soil profile within the active strip should be completed including the topsoil layer before rainfall occurs and before replacement is

suspended

- measures are required to protect the face of the soil layer from ponding of water and maintain the basal layer in a condition capable of supporting dump trucks
- The area to be restored is to be protected from in-flow of water, ponding etc. Wet sites must be drained in advance. Before the operation starts the basal layer should be to level and clean.

K.3 The timing of soil handling operations in England and Wales is set out in **Part One, Supplementary Note 4**. For directly placed soils this will use the in situ soil wetness protocol for soil stripping operations to determine the timing for soil replacement (Box K.3). For soil that has been stored, the relaying operation should be governed by the weather (rainfall) criteria set out in Box K.4. Here, the operation will generally need to be completed no later than the end of September unless the establishment of a satisfactory vegetation cover can be assured.

K.4 Soil handling is not to take place during rain, sleet or snow and in these conditions should be prohibited if unsafe for machine operations. Prior to commencing operations, a medium/long term weather forecast should be obtained which gives reasonable confidence of soil handling being completed without significant interruptions from rainfall events. The criteria set out in Box K.4 are to be used to determine whether soil handling should cease or be interrupted with the occurrence of rain.

K.5 All machines must be in a safe and efficient working condition at all times. The machines are to only work when ground conditions enable their efficient operation. The work should only be carried out when the basal layer supports the machinery without ruts or is capable of repair/maintenance. Otherwise the operation is to be suspended until suitable remedial measures can be put in place.

K.6 The operation should follow the detailed SRMP replacement plan showing the soil units to be replaced, haul routes and the phasing of vehicle movements. The soil units should be defined on the site with information to distinguish types and layers, and thickness and conveyed to the operational supervisor/operator. Different soil units to be kept

Box K.3 - Test for Dry and Friable Soils

Soil tests are to be undertaken in the field. Samples shall be taken from at least five locations on the soil handling area and at each soil horizon to the full depth of the profile to be recovered/replaced. The tests shall include visual examination of the soil and physical assessment of soil consistency.

i) Examination

- If the soil is wet, films of water are visible on the surface of soil particles or aggregates (e.g. clods or peds) and/or when a clod or ped is squeezed in the hand it readily deforms into a cohesive 'ball' means **no soil handling to take place**
- If the sample is moist (i.e. there is a slight dampness when squeezed in the hand) but it does not significantly change colour (darken) on further wetting, and clods break up/crumble readily when squeezed in the hand rather than forming into a ball means **soil handling can take place**
- If the sample is dry, it looks dry and changes colour (darkens) if water is added, and it is brittle means **soil handling can take place**

ii) Consistency

First Test

Attempt to mould soil sample into a ball by hand:

- Impossible because soil is too dry and hard or too loose and dry means soil handling can take place
- Impossible because the soil is too loose and wet means no soil handling to take place
- Possible - GO TO SECOND TEST

Second Test

Attempt to roll ball into a 3mm diameter thread by hand:

- Impossible because soil crumbles or collapses means **soil handling can take place**
- Possible means **no soil handling to take place**

NB: It is impossible to roll most coarse loamy and sandy soils into a thread even when they are wet. For these soils, the Examination Test alone is to be used.

Box K.4 - Rainfall Criteria:

- In light drizzle soil handling may continue for up to four hours unless the soils are already at/near to their moisture limit
- In light rain soil handling must cease after 15 minutes
- In heavy rain and intense showers, handling shall cease immediately.

In all of the above, after rain has ceased, soil tests shall be applied to determine whether handling may re-start, provided that the ground is free from ponding and ground conditions are safe to do so.

separate are to be marked out and information to distinguish types and layers, and ranges of thickness needs to be conveyed to the operational supervisor/machine operator. Detailed daily records should be kept of operations undertaken and site and soil conditions.

K.7 Profile boards should be used to control soil horizon thickness in each strip and overall levels achieved verified using soil pits. Allowances (i.e. a bulking factor) should be made for any settlement that may take place of the replaced loose soil.

K.8 The excavator and dump trucks are only to stand, work and travel on the basal/formation layer, and the bulldozer is to only operate on the topsoil after it is tipped onto the subsoil.

K.9 The excavator placed strip width and axis is to be demarcated. The strip width is determined by excavator boom length less the stand-off to operate; typically, about 3-4m (Box K.5). Excavators with long booms ('long reach') can be used, but may be more restricted by gradient limitations, and require skilled and experienced operators.

K.10 The type of bucket to be used largely depends on the nature of the soil (Box K.6).

K.11 The number of subsoil strips to be soiled before the sequentially tipped topsoil (**Figure K.3**) is spread to final level over the subsoil layer depends on the

Box K.5 - Orientation of the Excavator

Usually, the excavator is orientated and operates with its tracks at 90° to the axis of the strip being replaced as this is the most stable operating position.

Whilst the reach of the boom and hence the width of the bed/strip can be significantly increased by orientating it with the tracks parallel to edge of the soil being spread, this may affect the stability of the excavator, particularly on a gradient or where the basal layer has a low bearing capacity. Hence, its safe deployment needs to be checked before its adoption.

Box K.6 - Choice of Bucket Type

For hard /stony soils toothed buckets are needed. Where the mixing of soil layers at their interface is to be minimized, a bucket with a 'blade' is preferable where the soil is 'soft' and free of large stones or particularly stony stone free. Where there is a watching archaeological brief, the use of bladed buckets will normally be required.

Similarly, the choice of bucket type, whether it is a standard 'digging'/bulking or wide ditching type will depend on the soil strength and stoniness. The preferred type of bucket to place the subsoils is usually a digging/bulking bucket with an attached blade or a wide ditching bucket, but a toothed bucket can be used.

soiling capacity for the day's work as no subsoil should be left uncovered.

K.12 The dump truck reverses up to edge of the first strip to be subsoiled and tips the subsoil, without the wheels riding onto the basal layer (**Figures K.1 & K.2**). The dump truck should not drive away until all the subsoil is deposited within the strip without spillage; this may require assistance from the excavator to 'dig away' some of the tipped soil. The excavator is to spread the tipped subsoil to full thickness by digging, and using the pushing and pulling action of bucket.

K.13 Each load of subsoil should be spread following tipping before another is tipped. Should the spread soil comprise of large blocks (>300mm), normally these should be broken down by using the excavator bucket into smaller pieces before the next load is spread. The process is repeated until the strip is completely covered with the required depth of the subsoil layer.

K.14 On completion of the first subsoil strip, the topsoil needed to cover the soiled strip is to be tipped onto the subsoil. The dump truck reverses up to edge of the subsoil strip and tips the topsoil, without the wheels riding onto the subsoil (**Figure K.3**). The dump truck should not drive away until all the soil is deposited within the strip without spillage (see Box K.7); this may require assistance from the excavator to 'dig away' some of the tipped soil. The topsoil is to be spread to final depth after the completion of the further strips of subsoil (**Figure K.3**).

Box K.7 - Soil Profiles Greater Than 1m Thickness

When the replaced soil profiles reach about 1m in height from the basal layer it may not be possible to discharge the load from smaller dump trucks directly onto the previously placed lower layers because of the height of the dump truck body. The preferred solution is to tip the soil against the partially completed profile as heaps without the dump trucks rising onto or reversing into the placed material. The soil material is then lifted by the excavator onto the profile. It is considered preferable to accept some limited soil losses rather than to contaminate the topsoil with overburden. The loss of top-soil is minimised if the basal/formation layer is kept to level and clean.

K.15 On completion of the first subsoil strip and tipping the topsoil, repeat the process until sufficient strips have been placed to provide an adequate area for the bulldozer to work efficiently in spreading the topsoil to the final depth (**Figure K.3**).

K.16 At the end of each day the current strips should be completed if rain is forecast. If during a day it is evident that a full strip cannot be completed, then

complete the part of a strip that has been started to final topsoil level.

K.17 At the end of each day, or during the day if interrupted by rain, make provisions to protect base of restored strip from ponding/runoff by sumps and grips, and also clean and level the basal layer. At the start of each day ensure there is no ponding in the current strip or operating areas, and the basal layer is to level with no ruts.

Method with Integration of Remedial Actions

K.18 The following is the model methodology using the hybrid excavator, bulldozer and dump truck practice with the remedial interventions to demonstrate how integration is to be achieved. The key operational points to minimize the risk of severe soil compaction and soil wetness are summarised in Boxes K.1 and K.2 above.

K.19 Usually there will be a need for remedial treatment during the replacement operation with this machinery combination and handling practice. The placement of the stripped soils in storage is very likely to result in the need for remedial treatment. Where compaction occurs, treatment will need integrating into the replacement process as will any need for the removal of stones or non-soil debris. Both decompaction and removal of materials are covered in separate **Sheets L to O**. Where required, the early installation of under drainage can either be integrated sequentially during the replacement of the soils or later during the aftercare period.

K.20 Box K.8 sets out some of the remedial options/combinations to facilitate decompaction, and where necessary, the removal of stones and non-soil debris for a final profile comprising a basal layer, subsoil and topsoil layers. Except for Option 3, these actions need to be undertaken sequentially as each soil strip is placed.

K.21 Prior to commencing operations a weather forecast should be obtained which gives reasonable confidence of soil replacement proceeding without interruptions from rainfall events (Box K.4).

Box K.8 - Integration of Decompaction & Stone/Debris Removal

Option 1: is where the basal layer needs to be treated but is left until the subsoil is placed when both are decompacted together, followed by the decompaction of the topsoil and subsoil layers together (and basal layer) using tines that are long enough. This option is not suited to digging where the soil horizons would be mixed.

Option 2: is where each layer is treated separately by either tines or digging.

Option 3: is where the basal layer is treated or left untreated, followed by the placement of the subsoil and topsoil layers, which are to be decompacted by the use of tines. In the case of deep horizons this option can be limited by the capability of the machinery, the tines or bucket used. This option is not suited to digging where the soil horizons would be mixed.

K.22 If significant rainfall occurs during operations, the replacement must be suspended, and where the soil profile has been started it should be replaced to top-soil level. Replacement should not restart unless the weather forecast is expected to be dry for at least a full day and the soils are in a dry condition (Box K.3).

K.23 The operation should follow the detailed replacement plan in the SRMP showing the soil units to be replaced, haul routes and the phasing of vehicle movements. The soil units should be defined on the site with information to distinguish types and layers, and thickness and conveyed to the operational supervisor/operator. Different soil units to be kept separate are to be marked out and information to distinguish types and layers, and ranges of thickness needs to be conveyed to the operational supervisor/operator. Detailed daily records should be kept of operations undertaken and site and soil conditions (including the removal of stones and other non-soil debris that needs to be removed), and the results of the effectiveness of the work undertaken, and any need for additional remedial treatments.

K.24 Profile boards should be used to control soil horizon thickness in each strip and overall levels achieved verified using soil pits to verify. Allowances (i.e. a bulking factor) should be made for any settlement that may take place of the replaced loose soil.

K.25 The excavator and dump trucks are only to stand, work and travel on the basal/formation layer. Only where the remedial work involve the use of a bulldozer does machinery have to traffic the basal layer and subsoil(s) being treated, as the excavators work from the basal layer.

K.26 The initial strip width and axis is to be demarcated. Strip width is determined by excavator boom length less the stand-off to operate; typically, about 3-4m (see Box K.5). Excavators with long booms ('long reach') can be used, but may be more restricted by gradient limitations, and require skilled and experienced operators.

K.27 Where there is a requirement to treat compaction and/or remove stones/non-soil debris in the basal layer, these need to be carried out along the demarcated strip prior to the laying of subsoil.

K.28 Decompaction of the basal layer can be by digging with the excavator bucket (**Sheet N**) or by bulldozer drawn tines (**Sheet O**). Stone removal may require prior ripping/digging to release them from the basal material, followed by the excavator using a stone-rake bucket (the stone to be loaded on a dump truck and removed (**Sheet L**) or bulldozer with an excavator on the untreated basal layer loading the dump truck (**Sheet M**).

K.29 On completion of treating the basal layer, the loaded dump trucks reverse up to edge of the strip and tip the subsoil without the wheels riding onto the treated basal strip (**Figures K.1 & K.2**). The dump truck should not drive away until all the soil is deposited within the strip without spillage over the basal layer; this may require assistance from the excavator to 'dig away' some of the tipped soil. The excavator is to spread the tipped subsoil to full thickness by digging, and using the pushing and pulling action of bucket.

K.30 Each load of subsoil should be spread following tipping before another is tipped. Should the spread soil comprise of large blocks (>300mm), normally these should be broken down by using the excavator bucket to break the blocks into smaller pieces before the next load is spread. The process is repeated until the strip is completely covered with the required depth of the subsoil layer (**Figure K.2**).

K.31 The process of remedial treatment of the basal layer is repeated prior to each successive subsoil strip being soiled.

K.32 Where remedial treatment of the subsoil is required, either this is achieved one strip at a time (as for the basal layer) using excavators standing on the untreated basal strip (**Sheets L & N**) or by bulldozer methods (**Sheets M & O**) working on the subsoil surface where several strips are placed (see K.34 below).

K.33 Following the completion of the subsoil remedial treatments strip by strip, the topsoil is either tipped strip by strip when using the excavator options (**Sheets L & N**) or if several strips of subsoil are placed the topsoil is tipped along the final leading edge of the treated subsoil layer when using the bulldozer treatment options (**Sheets M & O**). In the latter the maximum number of subsoil strips to be soiled depends on the effective distance the low ground pressure bulldozer can push and spread the topsoil to depth the soil (with the minimal number of passes) from the advancing edge of the strips.

K.34 Where the remedial treatments are to be undertaken on the finished subsoil surface it is generally limited to the bulldozer option (**Sheets M & O**) because of the risk of further compaction from the excavator and dump truck option (**Sheets L & N**), although it is possible to arrange for the operations so that there is minimal trafficking and the retreating excavator treats any compacted areas. There is also the option of ripping with bulldozer tines (**Sheet O**) to treat compaction in the top- and subsoil layers together.

K.35 The sequentially tipped topsoil on the strips is pushed out to the final level of the subsoil by the minimal number of passes possible (**Figure K.3**) or

from the mound on the leading edge of a series of subsoil and treated strips.

K.36 Where there is a requirement for remedial treatments in the topsoil layer, this is undertaken on the finished topsoil surface.

Whilst it is generally limited to the bulldozer option (**Sheets M & O**) because of the risk of further compaction from the excavator and dump truck option (**Sheets L & N**), it is possible to arrange for the operations so that there is minimal trafficking and the retreating excavator treats any compacted areas. There is also the option of ripping with bulldozer tines (**Sheet O**) to treat compaction in the top- and subsoil layers together.

K.37 On completion of the topsoil layer the processes outlined above should be repeated for the next block of strips until the whole area to be restored is completed. Before the operation starts the basal layer should be to level and clean.

K.38 At the end of each day the current strip must be completed if rain is forecast. If during a day it is evident that a full strip cannot be completed, then complete the part of a strip that has been started.

K.39 At the end of each day, or during the day if interrupted by rain, make provisions to protect base of restored strip from ponding/runoff by sumps and grips, and also clean and level the basal layer. At the start of each day ensure there is no ponding in the current strip or operating areas, and the basal layer is to level with no ruts.

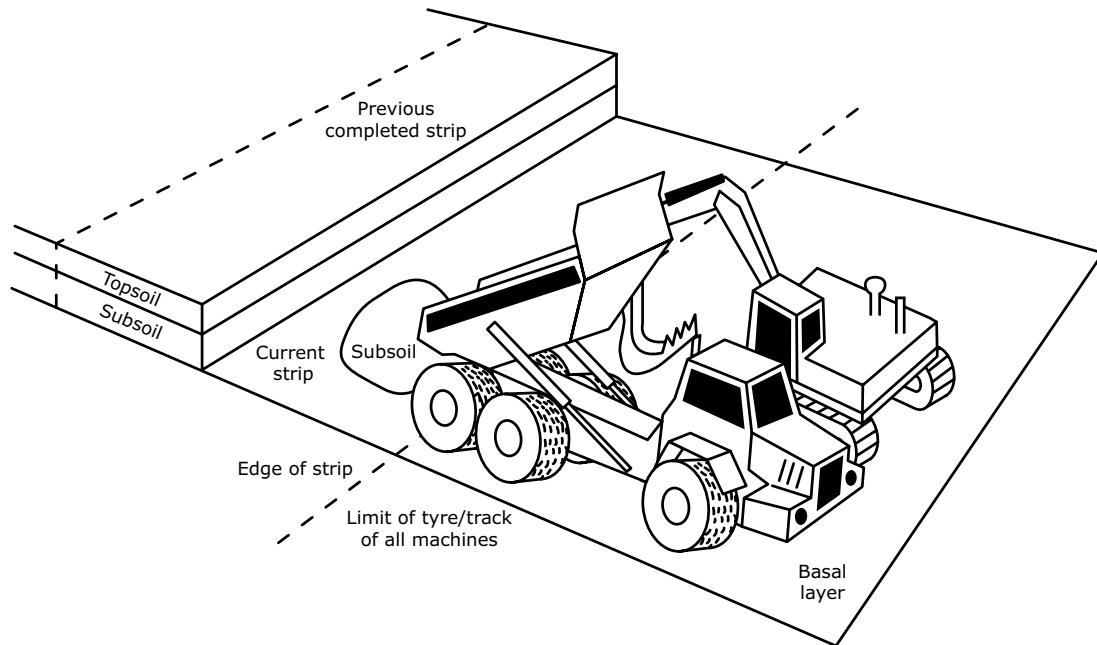

Figure K.1: Soil replacement with excavators and bulldozers using hybrid method: Subsoil.

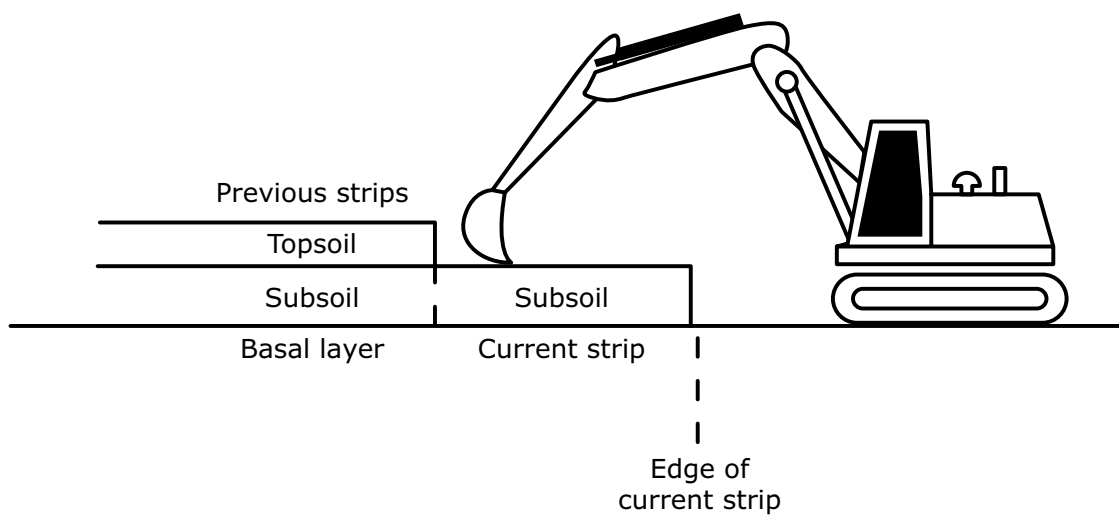

Figure K.2: Soil replacement with excavators and bulldozers using hybrid method: Subsoil.

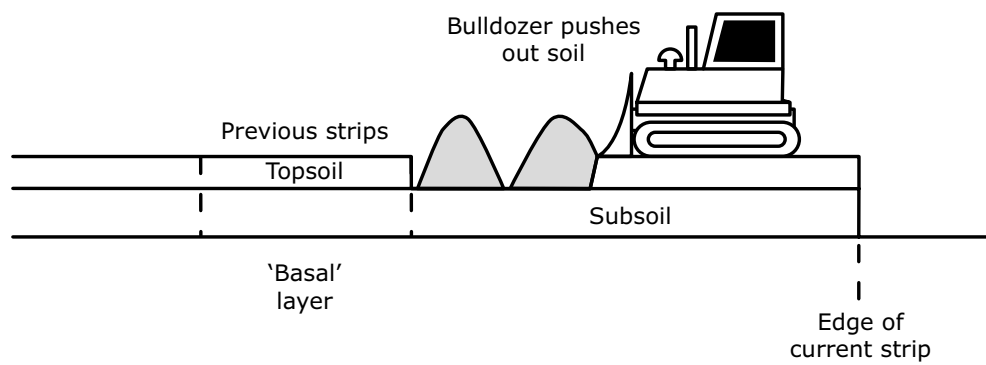
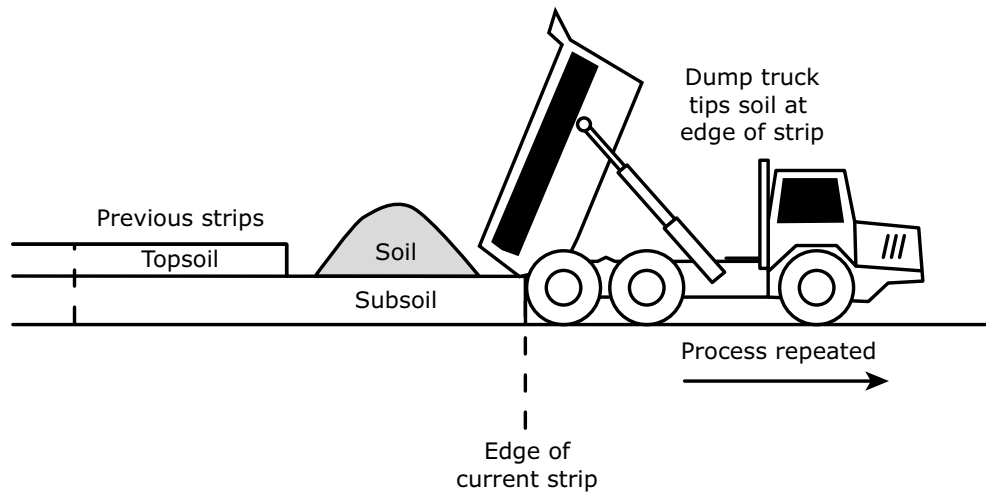

Figure K.3: Soil replacement with excavators and bulldozers using hybrid method: Topsoil.

GOOD PRACTICE GUIDE FOR HANDLING SOILS

In Mineral Workings

PART TWO: Model Methodology

- Sheet L -

Release & Removal of Stones and Non-Soil Debris
by Excavator & Stone-Rake

Author: Dr R N Humphries CBiol CSci FRSB FBSSS FIQ
- Blakemere Consultants Ltd & Celtic Energy Ltd

Supporting artwork was provided by R Shelton (H J Banks & Co)
and D Fisher (Blue Room Graphics Ltd).

Preface

The purpose of Sheet L of the guidance is to provide a model method of best practice where excavators are to be used to release and remove stones and non-soil debris from the basal layer and replaced soils.

The guidance is intended for use by planning officials, statutory consultees, mineral operators and their supporting teams and specialist consultants, and earth-moving contractors, their site supervisors and machine operators.

Successful soil handling schemes are dependent on the soil resources being clearly identified and the conditions in which they are to be handled. This information should be contained in the Soil Resource & Management Plan (SRMP) and communicated to those involved in its implementation.

Key issues to be addressed are:

- i) Avoiding conditions when soils are wet/plastic during handling
- ii) The minimisation of soil compaction caused by trafficking and soil wetness
- iii) Using appropriate remedial treatments where these are necessary
- iv) Minimising soil loss, and mixing of soil layers or different soil types.

The SRMP should specify the type of earth-moving machinery and soil handling practice, and the soil wetness condition (see Part One of the Guidance) to be deployed to achieve the planned after use, soil functioning, and the environmental and ecosystem services. It is to be communicated in full to all involved and in particular to the supervisors and machine operators by appropriate means; including tool-box talks and site demonstrations. Supervision by trained supervisory staff is essential, as are monitoring and reporting.

The guidance does not specify the size or model of equipment as this is left to the mineral operator and contractor to specify and provide. The machines must be of a kind which are appropriate for the task and the outcomes required, and to be able to carry out the work safely and efficiently.

Should the agreed methodology need to be modified or changed significantly, this should be agreed in advance with the mineral planning authority. The SRMP should include a mechanism whereby unexpected less significant changes can be quickly resolved through consultation between the operator, the planning authority and statutory consultee, and soil specialist.

All persons involved in the handling of soils must comply with all relevant legislation with respect to Health and Safety, in particular the Health and Safety at work Act 1974 and in the case of mineral extraction operations, The Quarries Regulations 1999 and its relevant statutory provisions; in particular those aspects which relate to the construction and removal of tips, mounds and similar structures. These requirements take preference over any suggested practice in this Sheet and the SRMP should have taken these into account.

The users of this guidance are solely responsible for ensuring it complies with all safety legislation and good practice, including the manufacturer's specifications for the safe operation of the specific machines being used, and that all machines are in a good condition and well maintained and are suitable for the task. It is important that those involved in the operation of earth moving machines are competent and have the necessary training and certification.

Introduction

The purpose of this Guidance Sheet is to provide a model method for best practice where stones and/or non-soil debris (e.g. wire rope, concrete blocks) are to be released using an excavator with a ripper claw and/or specialist stone-rake buckets from the basal layer and/or soils during replacement. The methodology can be deployed in combination with the machinery and practices presented in Sheets D, H, J and K.

Advantages & Disadvantages

The advantages are:

- i) It is an efficient means of removal of stones; and
- ii) It is very flexible with the quick interchange with digging bucket where needed for the removal of intransigent buried material
- iii) It can be an effective means of decompaction and cultivation of cloddy replaced soil
- iv) It serves to level the soil surfaces.

The disadvantages are:

- i) The effective reach of the excavator may limit the width of strips being treated or soils being placed
- ii) The effective release of stones from clayey soils is dependent on the soils being in a sufficiently 'dry' condition
- iii) The depth of release of material will be dependent on the length of the bucket's 'tines' (elongated teeth).
- iv) The size of stones is limited to the spacing of the bucket's 'tines' and may need different bucket sizes where a range of sizes are to be removed in successive soil layers
- v) There is a risk of removal of significant amounts of soil adhered to the stones and soil clods when they are hard and dry
- vi) There is a risk the removal of stones with dump trucks will result in the recompaction where trafficking the soil layers.

Suitability

This practice is the most suitable for a wide range of after uses and ecosystem services where stones are to be removed or the stone content is to be reduced, and it can be deployed on steep and complex landforms. The occurrence of large hard stones and non-soil debris can affect the agricultural potential of the restoration through interfering with/preventing cultivations and installation of underdrainage. The SRMP will have specified the need and particular requirements, within the soil replacement procedures, site conditions and after use aims.

Alternative methods to that described below can be considered. For example, there is often a preference to use agricultural tractor drawn stone rakes for the topsoil. There may be circumstances that it is economically viable to use soil screens to remove large stones and debris, particularly when the soils have been stockpiled.

Many former mineral workings have been backfilled with inert-waste. Remedial treatments of the infill, by digging or ripping, may not be advisable where these are not to be part of the replaced soil profile and this should be covered in the SRMP. The treatment of former silt-lagoons needs careful consideration and consultation with a geotechnical specialist where there is a possibility of breaking through the dewatered and stabilised upper material into the saturated underlying lower material.

MODEL METHODOLOGY

The Release & Removal Operation

L.1 The key operational points to minimise the risk of severe soil compaction and soil wetness are summarised in Boxes L.1 and L.2.

Box L.1 - To minimize compaction:

- Wherever possible the excavator and dump trucks receiving the released stones/non-soil debris are to operate on the basal layer
- The excavator with ripped claw or stone rake is only to work when soil conditions enable effective operation when the soils are in a 'dry' condition.

Box L.2

- The soil profile within the active strip should be completed to the topsoil layer before rainfall occurs and before replacement is suspended.
- Measures are required to protect the face of the soil layer from ponding of water and maintain the basal layer in a condition capable of supporting dump trucks.

L.2 The timing of soil handling operations should only take place when the soils are in a 'dry and friable' condition (ie when it breaks and shatters when disturbed rather than smears and deforms) (see **Part One, Supplementary Note 4**). Prior to the start or recommencement of soil handling they should be tested to confirm they are in suitably dry condition (see Box L.3).

L.3 Soil handling is not to take place during rain, sleet or snow and in these conditions should be prohibited due to unsafe machine operating conditions. Prior to commencing operations, a medium/long term weather forecast should be obtained which gives reasonable confidence of soil handling being completed without significant interruptions from rainfall events. The soil based criteria set out in Box L.4 are to be used to determine whether soil handling should cease or be interrupted with the occurrence of rain.

L.4 All machines must be in a safe and efficient working condition at all times. The machines are to only work when ground conditions enable safe and efficient operation. Otherwise the operation is to be suspended until suitable remedial measures can be put in place.

L.5 The operation should follow the detailed replacement plan set out in the SRMP showing soil units to be stripped, haul routes and the phasing of vehicle movements. Different soil units to be kept separate are to be marked out and information to distinguish types and layers, and ranges of thickness needs to be conveyed to the operational supervisor/operator. The haul routes and soil storage areas must be defined and should be stripped first in a similar manner. Detailed daily

Box L.3 - Test for Dry and Friable Soils

Soil tests are to be undertaken in the field. Samples shall be taken from at least five locations on the soil handling area and at each soil horizon to the full depth of the profile to be recovered/replaced. The tests shall include visual examination of the soil and physical assessment of soil consistency.

i) Examination

- If the soil is wet, films of water are visible on the surface of soil particles or aggregates (e.g. clods or peds) and/or when a clod or ped is squeezed in the hand it readily deforms into a cohesive 'ball' means **no soil handling to take place**
- If the sample is moist (i.e. there is a slight dampness when squeezed in the hand) but it does not significantly change colour (darken) on further wetting, and clods break up/crumble readily when squeezed in the hand rather than forming into a ball means **soil handling can take place**
- If the sample is dry, it looks dry and changes colour (darkens) if water is added, and it is brittle means **soil handling can take place**

ii) Consistency**First Test**

Attempt to mould soil sample into a ball by hand:

- Impossible because soil is too dry and hard or too loose and dry means soil handling can take place
- Impossible because the soil is too loose and wet means no soil handling to take place
- Possible - GO TO SECOND TEST

Second Test

Attempt to roll ball into a 3mm diameter thread by hand:

- Impossible because soil crumbles or collapses means **soil handling can take place**
- Possible means **no soil handling to take place**

NB: It is impossible to roll most coarse loamy and sandy soils into a thread even when they are wet. For these soils, the Examination Test alone is to be used.

records should be kept of operations undertaken, and site and soil conditions.

L.6 The excavator and dump trucks are to stand, work and travel on the soil or basal/formation layer according to the soil replacement practice being used (i.e. **Sheets, D, H, J & K**).

Box L.4 - Rainfall Criteria:

- In light drizzle soil handling may continue for up to four hours unless the soils are already at/near to their moisture limit
- In light rain soil handling must cease after 15 minutes
- In heavy rain and intense showers, handling shall cease immediately

In all of the above, after rain has ceased, soil tests shall be applied to determine whether handling may restart, provided that the ground is free from ponding and ground conditions are safe to do so.

L.7 The depth to which stones/damaging material can be dislodged and removed and the size of stones/materials depends on the configuration of the 'stone-rake', and the depth to which the soil/basal layer is dug in the procedure (Box L.5). For inert backfilled basal layers, the stone-rake probably can only be used when it has been decompacted first, either by an excavator with a standard bucket (see **Sheet N**) or ripping with tines (see **Sheet O**).

L.8 Where the removal of materials (wire rope, drums, tree roots, concrete lintels, etc) damaging to aftercare operations (e.g. cultivation, under-drainage installation) is not effective with the above stone-rake method, the operation is to be undertaken using digging buckets/ripper claw or tine equipment (see also **Sheets M & O**) to release the material and draw it aside for collection and disposal.

L.9 The release of stones is facilitated by the combing action of the excavator boom/tines on the stone-rake through the soil layer and to a depth required in the SRMP. For 'tines' 150-200 mm long a working depth of about 200-250 mm can be achieved.

Box L.5

There is a large range of stone-rake buckets and similar tools available for a range of stone sizes typically from 50mm to 150mm. Tine centres of less than 150mm tend to be more prone to clogging when used with clayey sub-soils, making this a practical size limit for stone removal. Where the stones to be removed from top-soils are less than 150mm, but greater than 20mm, 'finer' rakes can be used or a specialist stone picking machine. The removal of these smaller stones may only be required for certain after uses such as horticulture.



L.10 The 'radial' combing action (**Figure L.1**) is used to draw the stones towards the excavator for windrowing and loading into a dump truck for disposal or utilisation elsewhere. The radius is determined by the length of the excavator boom less the standoff to safely operate; typically, about 3-4m. Excavators with long booms ('long reach') can be used, but may be more restricted by gradient limitations, and require skilled and experienced operators.

L.11 Where the soil is a very fine texture (clayey) and has a relatively high moisture content, it can be difficult to break down soil clods and release the stones. In these circumstances the soil layer being treated may require cultivation with a bulldozer/tractor drawn heavy duty discs slightly offset from

the axis of travel.

L.12 Stone removal from the topsoil layer may be delayed until the whole area has been restored. If this option is adopted the use of the bucket method is not appropriate, and a tine cultivation method (e.g. **Sheet M**) should be used followed by removal of the stones by a specialist stone removal machine. If they are only few and large stones, these may be hand-picked and loaded into a tractor drawn trailer.

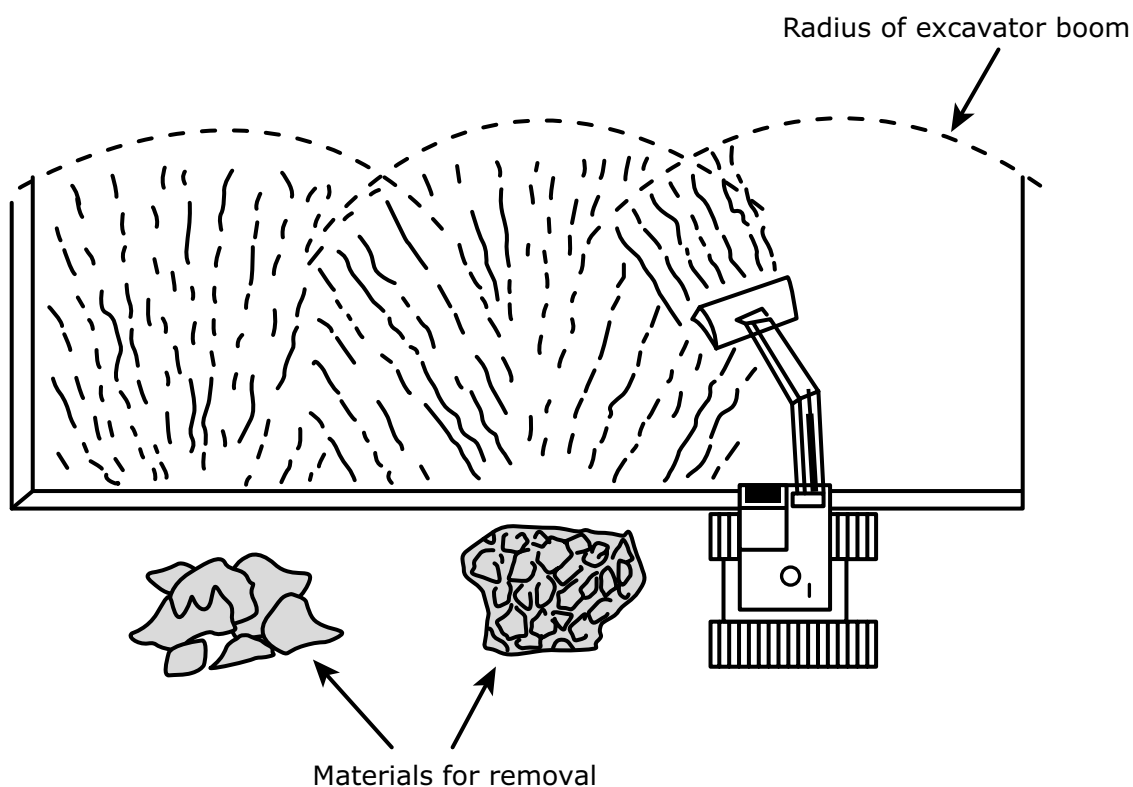

Figure L.1 Radial combing of soil surface to remove stones/damaging materials.

GOOD PRACTICE GUIDE FOR HANDLING SOILS

In Mineral Workings

PART TWO: Model Methodology

- Sheet M -

Release of Stones and Non-Soil Debris
by Bulldozer Drawn Tines

Author: Dr R N Humphries CBiol CSci FRSB FBSSS FIQ
- Blakemere Consultants Ltd & Celtic Energy Ltd

Supporting artwork was provided by R Shelton (H J Banks & Co)
and D Fisher (Blue Room Graphics Ltd).

Preface

The purpose of Sheet M of the guidance is to provide a model method of best practice where bulldozer drawn tines are to be used to release stones and non-soil debris from replaced soils and the basal layer.

The guidance is intended for use by planning officials, statutory consultees, mineral operators and their supporting teams and specialist consultants, and earth-moving contractors, their site supervisors and machine operators.

Successful soil handling schemes are dependent on the soil resources being clearly identified and the conditions in which they are to be handled. This information should be contained in the Soil Resource & Management Plan (SRMP) and communicated to those involved in its implementation.

Key issues to be addressed are:

- i) Avoiding conditions when soils are wet/ plastic during handling
- ii) The minimisation of soil compaction caused by trafficking and soil wetness
- iii) Using appropriate remedial treatments where these are necessary
- iv) Minimising soil loss, and mixing of soil layers or different soil types.

The SRMP should specify the type of earth-moving machinery and soil handling practice, and the soil wetness condition (see Part One of the Guidance) to be deployed to achieve the planned after use, soil functioning, and the environmental and ecosystem services. It is to be communicated in full to all involved and in particular to the supervisors and machine operators by appropriate means; including tool-box talks and site demonstrations. Supervision by trained supervisory staff is essential, as are monitoring and reporting.

The guidance does not specify the size or model of equipment as this is left to the mineral operator and contractor to specify and provide. The machines must be of a kind which are appropriate for the task and the outcomes required, and to be able to carry out the work safely and efficiently.

Should the agreed methodology need to be modified or changed significantly, this should be agreed in advance with the mineral planning authority. The SRMP should include a mechanism whereby unexpected less significant changes can be quickly resolved through consultation between the operator, the planning authority and statutory consultee, and soil specialist.

All persons involved in the handling of soils must comply with all relevant legislation with respect to Health and Safety, in particular the Health and Safety at work Act 1974 and in the case of mineral extraction operations, The Quarries Regulations 1999 and its relevant statutory provisions; in particular those aspects which relate to the construction and removal of tips, mounds and similar structures. These requirements take preference over any suggested practice in this Sheet and the SRMP should have taken these into account.

The users of this guidance are solely responsible for ensuring it complies with all safety legislation and good practice, including the manufacturer's specifications for the safe operation of the specific machines being used, and that all machines are in a good condition and well maintained and are suitable for the task. It is important that those involved in the operation of earth moving machines are competent and have the necessary training and certification.

Introduction

The purpose of this Guidance Sheet is to provide a model method for best practice where stones and/or non-soil debris (e.g. wire rope, concrete blocks) are to be released using bulldozer drawn tines from the basal layer and/or soils during replacement. The methodology can be deployed in combination with the machinery and practices presented in Sheets D, H, J and K.

Advantages & Disadvantages

The advantages are:

- i) It is an efficient means of removal of damaging materials
- ii) It is quick to deploy
- iii) It can be an effective means of decompaction (if it follows **Sheet O**).

The disadvantages are:

- i) The method requires excavators to load the collected stones/materials and to gather released stones the deployment
- ii) The need for excavators and dump trucks add another level of complexity and discipline needed in the soil replacement procedure
- iii) Ripping with tines is not an efficient means of releasing buried stones at depth (the tines tend to push them aside)
- iv) Effective release of stones from clayey soils is dependent on the soils being in a sufficiently 'dry' condition
- v) The depth of release of damaging material will be dependent on the effective length of the 'tines' (see **Sheet O**)
- vi) The size of stones dislodged is limited to the spacing of the 'tines' and pattern of ripping (see **Sheet O**)
- vii) There is a risk the removal of stones with dump trucks will result in the recompaction where trafficking the soil layers.

Suitability

The occurrence of large hard stones and non-soil debris can affect the agricultural potential of the restoration through interfering with/preventing cultivations and installation of underdrainage.

The SRMP will have specified the need and particular requirements, within the soil replacement procedures. The bulldozer drawn tines practice is the most commonly used method to release large stones/damaging materials for a wide range of after uses and ecosystem services where the content is to be reduced. It can be deployed on steep and complex landforms.

Alternative methods to that described below can be considered. For example, there is often a preference to use agricultural tractor drawn stone rakes for the topsoil. There may be circumstances that it is economically viable to use soil screens to remove large stones and debris, particularly when the soils have been stockpiled.

Many former mineral workings have been backfilled with inert waste. Remedial treatments of the infill, by digging or ripping, may not be advisable where these are not to be part of the replaced soil profile and this should be covered in the SRMP. The treatment of former silt lagoons needs careful consideration and consultation with a geotechnical specialist where there is a possibility of breaking through the dewatered and stabilised upper material into the saturated underlying lower material.

MODEL METHODOLOGY

The Release & Removal Operation

M.1 The key operational points to minimise the risk of severe soil compaction and soil wetness are summarised in Boxes M.1 and M.2.

Box M.1 - To minimize compaction:

- Wherever possible the bulldozer, excavator and dump trucks receiving the released stones/damaging material to operate on the basal layer
- The bulldozer used to release the stones/non-soil debris is only to work when soil conditions enable efficient operation
- If compaction is caused, then measures are required to treat it (see **Sheets N & O**)
- The operation should only be carried out when the soils are in a 'dry' condition.

Box M.2

- The soil profile within the active strip should be completed to the topsoil layer before rainfall occurs and before replacement is suspended
- Measures are required to protect the face of the soil layer from ponding of water and maintain the basal layer in a condition capable of supporting dump trucks.

M.2 The timing of soil handling operations should only take place when the soils are in a 'dry and friable' condition (ie when it breaks and shatters when disturbed rather than smears and deforms) (see Part One, Supplementary Note 4). Prior to the start or recommencement of soil handling they should be tested to confirm they are in suitably dry condition (see Box M.3).

M.3 Soil handling is not to take place during rain, sleet or snow and in these conditions should be prohibited due to unsafe machine operating conditions. Prior to commencing operations, a medium/long term weather forecast should be obtained which gives reasonable confidence of soil handling being completed without significant interruptions from rainfall events. The soil based criteria set out in Box M.4 are to be used to determine whether soil handling should cease or be interrupted with the occurrence of rain.

M.4 All machines must be in a safe and efficient working condition at all times. The machines are to only work when ground conditions enable safe and efficient operation. Otherwise the operation is to be suspended until suitable remedial measures can be put in place.

M.5 The operation should follow the detailed replacement plan set out in the SRMP showing soil units to be replaced, haul routes and the phasing of vehicle movements. Different soil units to be kept separate are to be marked out and information to distinguish types and layers, and ranges of thickness needs to be conveyed to the operational supervisor/operator. The haul routes

Box M.3 - Test for Dry and Friable Soils

Soil tests are to be undertaken in the field. Samples shall be taken from at least five locations on the soil handling area and at each soil horizon to the full depth of the profile to be recovered/replaced. The tests shall include visual examination of the soil and physical assessment of soil consistency.

i) Examination

- If the soil is wet, films of water are visible on the surface of soil particles or aggregates (e.g. clods or peds) and/or when a clod or ped is squeezed in the hand it readily deforms into a cohesive 'ball' means **no soil handling to take place**
- If the sample is moist (i.e. there is a slight dampness when squeezed in the hand) but it does not significantly change colour (darken) on further wetting, and clods break up/crumble readily when squeezed in the hand rather than forming into a ball means **soil handling can take place**
- If the sample is dry, it looks dry and changes colour (darkens) if water is added, and it is brittle means **soil handling can take place**

ii) Consistency**First Test**

Attempt to mould soil sample into a ball by hand:

- Impossible because soil is too dry and hard or too loose and dry means soil handling can take place
- Impossible because the soil is too loose and wet means no soil handling to take place
- Possible - GO TO SECOND TEST

Second Test

Attempt to roll ball into a 3mm diameter thread by hand:

- Impossible because soil crumbles or collapses means **soil handling can take place**
- Possible means **no soil handling to take place**

NB: It is impossible to roll most coarse loamy and sandy soils into a thread even when they are wet. For these soils, the Examination Test alone is to be used.

Box M.4 - Rainfall Criteria:

- In light drizzle soil handling may continue for up to four hours unless the soils are already at/near to their moisture limit
- In light rain soil handling must cease after 15 minutes
- In heavy rain and intense showers, handling shall cease immediately

In all of the above, after rain has ceased, soil tests shall be applied to determine whether handling may restart, provided that the ground is free from ponding and ground conditions are safe to do so.

and soil storage areas must be defined and should be stripped first in a similar manner. Detailed daily records should be kept of operations undertaken, and site and soil conditions.

M.6 The excavator and dump trucks used to collect and dispose of the material, are to stand, work and travel on the soil or basal/formation layer according to the SMP and soil replacement practice being used (i.e. **Sheets D, H, J & K**).

M.7 Ripping with bulldozer drawn tines can be used to release large stones (typically >150mm) and damaging materials (wire rope, tree roots, drums, concrete lintels etc) from the replaced soils and basal/formation layers. Where the stones to be removed are less than 150mm, but greater than 20mm, a specialist stone-rake or stone picking machine will have to be used. The use of the latter equipment is generally only applicable to the topsoil layer. The removal of these smaller stones should be part of the cultivation phase for cropping and is outside the scope of this guidance.

M.8 Where large stones and non-soil debris are damaging to aftercare operations (e.g. cultivations, underdrainage installation) they are to be removed, the equipment and practices set out here (Figure M.1) can be used and integrated into the procedures listed in **Sheets D, H, J and K**.

M.9 On completion of each soil layer or as required by the SRMP), and prior to the replacement of the

next layer the surface (as a strip/layer) available according to the handling methodology being used (see **Sheets D, H, J & K**), the area to be treated is ripped (**Figure M.1**) and where necessary with overlapping passes (**Figure O.4, Sheet O**). Generally, effective release is only achieved from the 300mm of the soil/basal layer (i.e. the height of the 'heave' above the pre-ripped ground surface caused by the ripping tool).

M.10 Bulldozers with closely spaced (0.3-0.5 m) 'stub' tines (400 mm from tip to tool bar base) are often more effective in releasing stones than deep ripping equipment designed to alleviate severe compaction at depth. Where non-soil debris is to be removed, straight legged tines without wings (see **Sheet O.2**) are the most suitable equipment; particularly in the case of basal/formation materials. Alternatively, high powered rubber-tyre tractors pulling heavy duty multi-tine cultivators can be used (depending on soil texture and moisture content).

M.11 Traditionally, large (>150 mm) stones released are collected by hand and loaded into tractor-drawn trailers travelling and standing on the soil/basal layer. Where there is a quantity of stone to be removed, the excavator with stone-rakes methodology may have to be deployed (see Sheet L) thereby, possibly negating the need of this methodology using tines.

M.12 The tines are used to release and lift non-soil debris to the surface and drag them to the edge of the strip for collection and disposal. Any equipment/machinery used for the latter is only to travel and stand on the basal/formation layer.

M.13 Where the soil is a very fine texture (clayey) and has a relatively high moisture content, it can be difficult to break down soil clods and release the stones. In these circumstances the soil layer being treated may require cultivation with a bulldozer/tractor drawn heavy duty discs slightly offset to run along the axis of travel.

M.14 Stone removal from the topsoil layer can be delayed until the whole area has been restored. A shallower ripping (300mm) and/or discing with heavy duty disc cultivators of the topsoil will be needed to

release the stone followed by removal of the stones by a specialist stone removal machine. If they are only few and large stones, these may be hand-picked and loaded into a tractor drawn trailer. If this option is adopted, trafficking of the topsoil layer will take place during the collection of the stones and remedial treatment of the recompaction will be required.

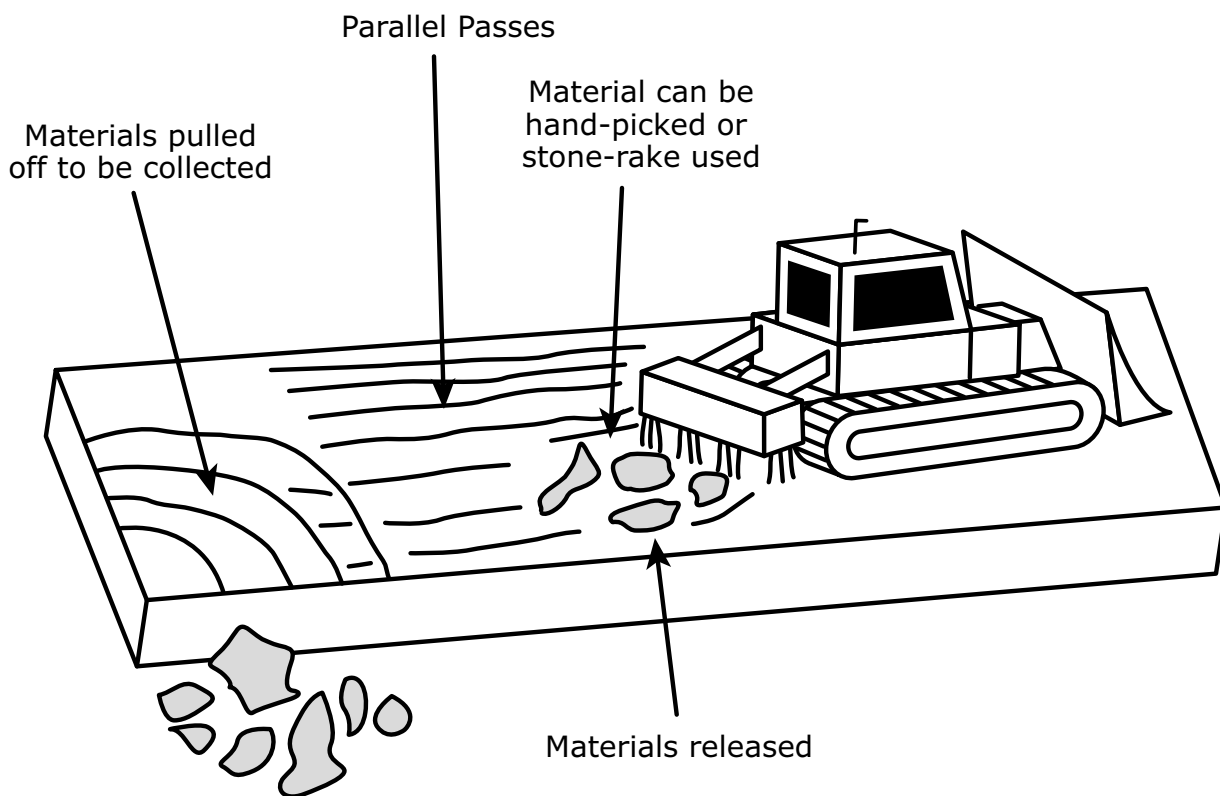

Figure M.1 Ripping with tines to release large stones and damaging materials.

GOOD PRACTICE GUIDE FOR HANDLING SOILS

In Mineral Workings

PART TWO: Model Methodology

- Sheet N -

Soil Decompaction by Excavator Bucket

Author: Dr R N Humphries CBiol CSci FRSB FBSS FIQ
- Blakemere Consultants Ltd & Celtic Energy Ltd

Supporting artwork was provided by R Shelton (H J Banks & Co)
and D Fisher (Blue Room Graphics Ltd).

Preface

The purpose of Sheet N of the guidance is to provide a model method of best practice where excavators are to be used to decompact replaced soils and the basal layer by digging with a bucket.

The guidance is intended for use by planning officials, statutory consultees, mineral operators and their supporting teams and specialist consultants, and earth-moving contractors, their site supervisors and machine operators.

Successful soil handling schemes are dependent on the soil resources being clearly identified and the conditions in which they are to be handled. This information should be contained in the Soil Resource & Management Plan (SRMP) and communicated to those involved in its implementation.

Key issues to be addressed are:

- i) Avoiding conditions when soils are wet/plastic during handling
- ii) The minimisation of soil compaction caused by trafficking and soil wetness
- iii) Using appropriate remedial treatments where these are necessary
- iv) Minimising soil loss, and mixing of soil layers or different soil types.

The SRMP should specify the type of earth-moving machinery and soil handling practice, and the soil wetness condition (see Part One of the Guidance) to be deployed to achieve the planned after use, soil functioning, and the environmental and ecosystem services. It is to be communicated in full to all involved and in particular to the supervisors and machine operators by appropriate means; including tool-box talks and site demonstrations. Supervision by trained supervisory staff is essential, as are monitoring and reporting.

The guidance does not specify the size or model of equipment as this is left to the mineral operator and contractor to specify and provide. The machines must be of a kind which are appropriate for the task and the outcomes required, and to be able to carry out the work safely and efficiently.

Should the agreed methodology need to be modified or changed significantly, this should be agreed in advance with the mineral planning authority. The SRMP should include a mechanism whereby unexpected less significant changes can be quickly resolved through consultation between the operator, the planning authority and statutory consultee, and soil specialist.

All persons involved in the handling of soils must comply with all relevant legislation with respect to Health and Safety, in particular the Health and Safety at work Act 1974 and in the case of mineral extraction operations, The Quarries Regulations 1999 and its relevant statutory provisions; in particular those aspects which relate to the construction and removal of tips, mounds and similar structures. These requirements take preference over any suggested practice in this Sheet and the SRMP should have taken these into account.

The users of this guidance are solely responsible for ensuring it complies with all safety legislation and good practice, including the manufacturer's specifications for the safe operation of the specific machines being used, and that all machines are in a good condition and well maintained and are suitable for the task. It is important that those involved in the operation of earth moving machines are competent and have the necessary training and certification.

Introduction

The purpose of this Guidance Sheet is to provide a model method for best practice where an excavator is used to decompact soils and basal/formation layers. Excavators are most likely to be used for this purpose where soils are replaced by excavator (Sheet D), however the methodology can be deployed in combination with the machinery and practices presented in Sheets H, J and K.

Advantages & Disadvantages

The advantages of the methodology are:

- i) It is an efficient means of decompaction
- ii) The equipment is standardized and readily available
- iii) It is flexible with the quick interchange with a stone-rake for the need remove stones or level/cultivate a final surface
- iv) It is suited to single shallow soil layer.

The disadvantages are:

- i) The deployment adds another level of complexity needed in the soil replacement and skill and discipline in the decompaction procedures
- ii) The methodology is significantly slower than the alternative of ripping (**Sheet S**)
- iii) The effective decompaction is dependent on the soils being in a sufficiently 'dry' condition
- iv) There is a risk of mixing of soil horizons.

Suitability

This practice is the most suitable for a wide range of and uses, soil functions, and environmental and ecosystem services where decompaction is required. It can be deployed on steep and complex landforms. Like with the use of tines (**Sheet O**), to be effective the soil must be dry enough to shatter. The SRMP will have specified the need and particular requirements, within the soil replacement procedures, site conditions land and use aims.

Many former mineral workings have been backfilled with inert waste. Remedial treatments of the infill, by digging or ripping, may not be advisable where these are not to be part of the replaced soil profile and this should be covered in the SRMP. The

treatment of former silt lagoons needs careful consideration and consultation with a geotechnical specialist where there is a possibility of breaking through the dewatered and stabilised upper material into the saturated underlying lower material.

MODEL METHODOLOGY

The Decompaction Operation

N.1 Key operational points to minimize the risk of severe soil compaction and soil wetness are summarised in Boxes N.1 and N.2.

Box N.1 - To minimize compaction:

- Wherever possible the excavator is to operate on the basal layer
- The excavator is only to work when ground conditions enable efficient operation
- The operation should only be carried out when the soils are in a 'dry' condition.

Box N.2

- The soil profile within the active strip should be completed to the topsoil layer before rainfall occurs and before replacement is suspended
- Measures are required to protect the face of the soil layer from ponding of water and maintain the basal layer in a condition capable of supporting dump trucks.

N.2 The timing of soil handling operations should only take place when the soils are in a 'dry and friable' condition (i.e. when it breaks and shatters when disturbed rather than smears and deforms) (see **Part One, Supplementary Note 3**). Prior to the start or recommencement of soil handling they should be tested to confirm they are in suitably dry condition (see Box N.3).

N.3 Soil handling is not to take place during rain, sleet or snow and in these conditions should be prohibited due to unsafe machine operating conditions. Prior to commencing operations, a medium/long term weather forecast should be obtained which gives reasonable confidence of soil handling being completed without significant interruptions from rainfall events. The soil based

Box N.3 - Test for Dry and Friable Soils

Soil tests are to be undertaken in the field. Samples shall be taken from at least five locations on the soil handling area and at each soil horizon to the full depth of the profile to be recovered/replaced. The tests shall include visual examination of the soil and physical assessment of soil consistency.

i) Examination

- If the soil is wet, films of water are visible on the surface of soil particles or aggregates (e.g. clods or peds) and/or when a clod or ped is squeezed in the hand it readily deforms into a cohesive 'ball' means **no soil handling to take place**
- If the sample is moist (i.e. there is a slight dampness when squeezed in the hand) but it does not significantly change colour (darken) on further wetting, and clods break up/crumble readily when squeezed in the hand rather than forming into a ball means **soil handling can take place**
- If the sample is dry, it looks dry and changes colour (darkens) if water is added, and it is brittle means **soil handling can take place**

ii) Consistency**First Test**

Attempt to mould soil sample into a ball by hand:

- Impossible because soil is too dry and hard or too loose and dry means soil handling can take place
- Impossible because the soil is too loose and wet means no soil handling to take place
- Possible - GO TO SECOND TEST

Second Test

Attempt to roll ball into a 3mm diameter thread by hand:

- Impossible because soil crumbles or collapses means **soil handling can take place**
- Possible means **no soil handling to take place**

NB: It is impossible to roll most coarse loamy and sandy soils into a thread even when they are wet. For these soils, the Examination Test alone is to be used.

criteria set out in BOX N.4 are to be used to determine whether soil handling should cease or be interrupted with the occurrence of rain.

N.3 Soil handling is not to take place during rain, sleet or snow and in these conditions should be prohibited due to unsafe machine operating conditions. Prior to commencing operations, a medium/long term weather forecast should be obtained which gives reasonable confidence of soil handling being completed without significant interruptions from rainfall events. The soil based criteria set out in Box N.4 are to be used to determine whether soil handling should cease or be interrupted with the occurrence of rain.

Box N.4 - Rainfall Criteria:

- In light drizzle soil handling may continue for up to four hours unless the soils are already at/near to their moisture limit
- In light rain soil handling must cease after 15 minutes
- In heavy rain and intense showers, handling shall cease immediately

In all of the above, after rain has ceased, soil tests shall be applied to determine whether handling may restart, provided that the ground is free from ponding and ground conditions are safe to do so.

N.4 All machines must be in a safe and efficient working condition at all times. The machines are to only work when ground conditions enable safe and efficient operation. Otherwise the operation is to be suspended until suitable remedial measures can be put in place.

N.5 The operation should follow the detailed replacement plan set out in the SRMP showing soil units to be stripped, haul routes and the phasing of vehicle movements. Different soil units to be kept separate are to be marked out and information to distinguish types and layers, and ranges of thickness needs to be conveyed to the operational supervisor/operator. The haul routes and soil storage areas must be defined and should be stripped first in a similar manner. Detailed daily records should be kept of operations undertaken, and site and soil conditions.

N.6 The digging radius is determined by excavator boom length less the stand-off to operate; typically, about 3-4m. Excavators with long booms ('long reach') can be used, but may be more restricted by gradient limitations, and require skilled and experienced operators. The excavator bucket is to be maximum capacity of 2.5m³ and 1.0 m to 1.5m wide cutting edge (blade) with armoured teeth at about 150 mm spacing, 150 mm long and 50mm in section.

N.7 The excavator should stand on and work from the basal/formation layer wherever possible.

N.8 Where the soil layer to be decompacted as a single layer and is less than about 0.5m thick the following procedure is to be adopted. The area to be treated is decompacted as a series of sequential 'trenches' to the depth required (**Figure N.1**).

N.9 Each trench is to be the effective working length of the excavator boom (nominally 3-4m). The trench is started by inserting the bucket 'blade' downwards into the soil to the depth required and keeping this vertical attitude pulled towards the excavator (**Figure N.1**). When the bucket is almost filled it is lifted and the soil tipped into the 'trench' created. The bucket's tines have a ripping action and the pushing of the soil into the bucket has a shattering effect if the soil is dry enough, otherwise it will compress the soil material with no resulting beneficial effect. If the replaced soil in the trench is cloddy, it can be 'chopped' using the bucket's blade. The process is repeated until the trench has been decompacted, then another trench is treated until the whole area to be treated is completed. It is essential each successive bucket 'dig' overlaps with the former both to the back and sides of the trenches. Finally, the bucket cutting edge can be used to lightly grade the finished surface.

N.10 Where the soil layer is deeper than the capability of the bucket (about 0.5m), a 'double-digging' approach is needed. The process is similar to above, but the upper material in the trench is to be cast aside over the adjacent untreated strip ('double digging'). The exposed lower layer is then treated as above and on completion the cast aside upper material is replaced with any necessary

cultivation/levelling with the bucket taking place. This method is relatively slow.

N.11 The alternative for deep profiles than 0.5m to be decompacted by the excavator method is to place the soil layer in several successive sub-layers each up to 0.5m in thickness, and to sequentially decompact each replaced layer as described above. The process is repeated until the full soil horizon is replaced to the required thickness and has been completely 'dug over'. This method is also slow.

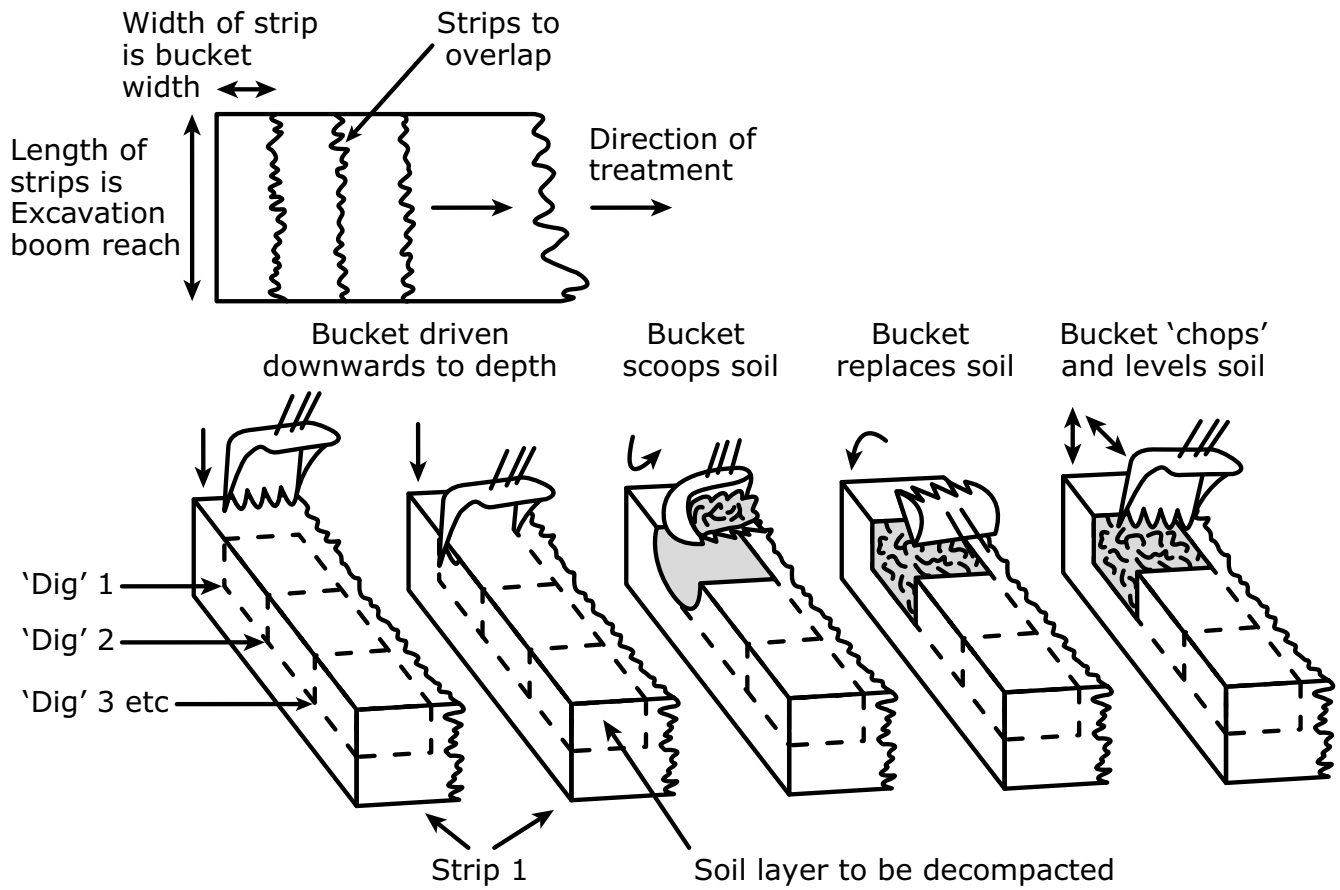

Figure N.1 Decompaction by excavator bucket..

GOOD PRACTICE GUIDE FOR HANDLING SOILS

In Mineral Workings

PART TWO: Model Methodology

- Sheet O -

Soil Decompaction by
Bulldozer Drawn Tines

Author: Dr R N Humphries CBiol CSci FRSB FBSS FIQ
- Blakemere Consultants Ltd & Celtic Energy Ltd

Supporting artwork was provided by R Shelton (H J Banks & Co)
and D Fisher (Blue Room Graphics Ltd).

Preface

The purpose of Sheet O of the guidance is to provide a model method of best practice where bulldozer drawn tines are to be used to decompact soils.

The guidance is intended for use by planning officials, statutory consultees, mineral operators and their supporting teams and specialist consultants, and earth-moving contractors, their site supervisors and machine operators.

Successful soil handling schemes are dependent on the soil resources being clearly identified and the conditions in which they are to be handled. This information should be contained in the Soil Resource & Management Plan (SRMP) and communicated to those involved in its implementation.

Key issues to be addressed are:

- i) Avoiding conditions when soils are wet/ plastic during handling
- ii) The minimisation of soil compaction caused by trafficking and soil wetness
- iii) Using appropriate remedial treatments where these are necessary
- iv) Minimising soil loss, and mixing of soil layers or different soil types.

The SRMP should specify the type of earth-moving machinery and soil handling practice, and the soil wetness condition (see Part One of the Guidance) to be deployed to achieve the planned after use, soil functioning, and the environmental and ecosystem services. It is to be communicated in full to all involved and in particular to the supervisors and machine operators by appropriate means; including tool-box talks and site demonstrations. Supervision by trained supervisory staff is essential, as are monitoring and reporting.

The guidance does not specify the size or model of equipment as this is left to the mineral operator and contractor to specify and provide. The machines must be of a kind which are appropriate for the task and the outcomes required, and to be able to carry out the work safely and efficiently.

Should the agreed methodology need to be modified or changed significantly, this should be agreed in advance with the mineral planning authority. The SRMP should include a mechanism whereby unexpected less significant changes can be quickly resolved through consultation between the operator, the planning authority and statutory consultee, and soil specialist.

All persons involved in the handling of soils must comply with all relevant legislation with respect to Health and Safety, in particular the Health and Safety at work Act 1974 and in the case of mineral extraction operations, The Quarries Regulations 1999 and its relevant statutory provisions; in particular those aspects which relate to the construction and removal of tips, mounds and similar structures. These requirements take preference over any suggested practice in this Sheet and the SRMP should have taken these into account.

The users of this guidance are solely responsible for ensuring it complies with all safety legislation and good practice, including the manufacturer's specifications for the safe operation of the specific machines being used, and that all machines are in a good condition and well maintained and are suitable for the task. It is important that those involved in the operation of earth moving machines are competent and have the necessary training and certification.

Introduction

The purpose of this Guidance Sheet is to provide a model method for best practice where bulldozer drawn tines are used to decompact soils and basal/formation layers. Tines are most likely to be used for this purpose where soils are replaced by bulldozers and dump truck combinations (Sheets H, J & K), however, the methodology can be deployed in the excavator machinery combinations and practices presented (Sheet D).

Advantages & Disadvantages

The advantages of the methodology are:

- i) The practice is relatively simple to deploy when there are suitable ripping tools and experience in their proper use
- ii) The procedure is relatively quick to administer
- iii) Significant mixing of soil horizons can be minimized
- iv) It can be deployed on steep and complex landforms.

The disadvantages are:

- i) The deployment adds another level of complexity needed in the soil replacement and skill and discipline in the decompaction procedures
- ii) Whilst there is wide familiarity with the technique, there is little understanding of its limitations
- iii) Adequate ripping tools in a good condition can be difficult to locate
- iv) The method is sensitive to soil being too wet (plastic)

Suitability

Where conditions are suitable, the practice can be deployed for a wide range of after uses, soil functions, and environmental and ecosystem services, where decompaction is required. Like with the use of excavators (**Sheet N**), to be effective the soil must be dry enough to shatter. The SRMP will have specified the need and particular requirements, within the particular soil replacement procedures, site conditions and land use aims.

Many former mineral workings have been backfilled with inert waste. Remedial treatments of the infill, by digging or ripping, may not be advisable where these are not to be part of the replaced soil profile and this should be covered in the SRMP. The treatment of former silt lagoons needs careful consideration and consultation with a geotechnical specialist where there is a possibility of breaking through the dewatered and stabilised upper material into the saturated underlying lower material.

MODEL METHODOLOGY

The Decompaction Operation

O.1 Key operational points to minimize the risk of severe soil compaction and soil wetness are summarised in Boxes O.1 and O.2.

Box O.1 - To maximize the effectiveness of decompaction treatments:

- The moisture content of the soils should be at least 5% below their plastic limit, or greater if so advised
- The ripping pattern must be overlapping parallel passes and recompaction at depth must be treated in the ripping strategy
- The tines should be sufficiently closely spaced to ensure that full lateral decompaction is achieved with overlapping passes
- The use of winged straight tines is recommended
- the tine length and width must be compatible with the proposed depth of decompaction and allow for soil 'heave'
- Tine and wings must have wear plates and be in good operating condition. Worn and deformed tools must not be used
- The towing unit must be capable of pulling the tine combination in an operationally efficient manner, without undue weaving and track slippage.

O.2 The timing of soil handling operations should only take place when the soils are in a 'dry and friable' condition (ie when it breaks and shatters when disturbed rather than smears and deforms) (see **Part One, Supplementary Notes 3 & 4**).

Box O.2 - To minimize re-wetting:

- The ripping should not be undertaken if significant rainfall is forecast
- Where the soil profile is partly raised to ground level, the uppermost soil layer should be left in an unripped state. Where the subsoil layer has been ripped, but the topsoil not placed, it should be sealed by blading with a bulldozer. On resumption of operations, the upper and lower layers will require decompacting

Prior to the start or recommencement of soil handling they should be tested to confirm they are in suitably dry condition (see Box O.3).

O.3 Soil handling is not to take place during rain, sleet or snow and in these conditions should be prohibited due to unsafe machine operating conditions. Prior to commencing operations, a medium/long term weather forecast should be obtained which gives reasonable confidence of soil handling being completed without significant interruptions from rainfall events. The soil based criteria set out in BOX O.4 are to be used to determine whether soil handling should cease or be interrupted with the occurrence of rain.

O.4 All machines must be in a safe and efficient working condition at all times. The machines are to only work when ground conditions enable safe and efficient operation. Otherwise the operation is to be suspended until suitable remedial measures can be put in place.

O.5 The operation should follow the detailed replacement plan set out in the SRMP showing soil units to be stripped, haul routes and the phasing of vehicle movements. Different soil units to be kept separate are to be marked out and information to distinguish types and layers, and ranges of thickness needs to be conveyed to the operational supervisor/operator. The haul routes and soil storage areas must be defined and should be stripped first in a similar manner. Detailed daily records should be kept of operations undertaken, and site and soil conditions.

Box O.3 - Test for Dry and Friable Soils

Soil tests are to be undertaken in the field. Samples shall be taken from at least five locations on the soil handling area and at each soil horizon to the full depth of the profile to be recovered/replaced. The tests shall include visual examination of the soil and physical assessment of soil consistency.

i) Examination

- If the soil is wet, films of water are visible on the surface of soil particles or aggregates (e.g. clods or peds) and/or when a clod or ped is squeezed in the hand it readily deforms into a cohesive 'ball' means **no soil handling to take place**
- If the sample is moist (i.e. there is a slight dampness when squeezed in the hand) but it does not significantly change colour (darken) on further wetting, and clods break up/crumble readily when squeezed in the hand rather than forming into a ball means **soil handling can take place**
- If the sample is dry, it looks dry and changes colour (darkens) if water is added, and it is brittle means **soil handling can take place**

ii) Consistency**First Test**

Attempt to mould soil sample into a ball by hand:

- Impossible because soil is too dry and hard or too loose and dry means soil handling can take place
- Impossible because the soil is too loose and wet means no soil handling to take place
- Possible - GO TO SECOND TEST

Second Test

Attempt to roll ball into a 3mm diameter thread by hand:

- Impossible because soil crumbles or collapses means **soil handling can take place**
- Possible means **no soil handling to take place**

NB: It is impossible to roll most coarse loamy and sandy soils into a thread even when they are wet. For these soils, the Examination Test alone is to be used.

Box O.4 - Rainfall Criteria:

- In light drizzle soil handling may continue for up to four hours unless the soils are already at/near to their moisture limit
- In light rain soil handling must cease after 15 minutes
- In heavy rain and intense showers, handling shall cease immediately

In all of the above, after rain has ceased, soil tests shall be applied to determine whether handling may restart, provided that the ground is free from ponding and ground conditions are safe to do so.

Ripping Strategies

O.6 Ripping to decompact soils is a necessary part of the soil replacement procedures using bulldozer-dump truck combinations. The primary aim of the ripping strategy is to ensure that there is no significant compaction within the soil profile which might impede root growth or drainage. There are two basic ripping strategies that can be used:

- When the soil profile is ripped sequentially as the soil layers are built up; and
- When it is ripped only after the full profile is complete.

O.7 Sequential ripping of each layer before next is placed has to be carried out during the replacement operations (**Figure O.1a**). The ripping of the final surface layer can be delayed until all the topsoil layer has been replaced. It is appropriate when:

- The soil profile/horizon thickness exceeds the effective depth of the tine or capacity of the towing unit being used; a number of sequential rips are required, each layer ripped before the next is placed
- The depth of subsequent sequential ripping must relieve any recompaction of the lower layers following the placement of the new overlying layer or other surface operations
- Stones and/or damaging materials are to be released and removed from sub-surface horizons.

O.8 Single deep ripping on completion of profile (**Figure O.1b**): It is appropriate when:

- The profile thickness is equivalent to or less than the effective depth of tine and capabilities of towing unit
- Large stones and/or non-soil debris are absent or need not be removed from sub-surface horizons
- Debris or stones need only to be removed from surface topsoil layer, where a shallower surface cultivation would be carried out prior to final ripping
- Sequential ripping has been undertaken and there is still recompaction at depth
- Final ripping can be delayed until all strips and final works complete, or later in aftercare period.

O.9 Both strategies have their limitations and the selection should be compatible with the land use, soil function, environmental and ecosystem services objectives, the soil profile in question and the capability of the equipment to be used. It may not be possible to treat deep compaction or even compaction at moderate depth once the profile has been completed. Hence, it is essential that the correct strategy is adopted. In some circumstances it may be necessary to adopt a combination of both strategies to achieve satisfactory results.

Equipment

O.10 Bulldozer units of a minimum 300hp are usually required to be able to carry out the operations effectively (Box O.5).

O.11 There are two types of ripping units:

- Frame-mounted on a bulldozer unit and often hydraulic operated
- Mounted on towed trailers/tool carriers and either cable or hydraulic operated.

Control mechanisms have to be compatible between the bulldozer unit and tool carriers

Box O.5

Approximately 30hp/leg or shank on multiple tine beam cultivator to 750mm depth and 100hp/tine three leg or shank to 750mm depth.

O.12 There are two types of tines: straight leg and curved leg. The former is the most commonly used and is the principal tool for decompaction. Straight tines are to be used where there are obstructions, or the soils/formation layer is excessively stony. Curved tines are typically used, in combination with straight tines, and set to operate at shallower depth for the purpose of reducing the 'drag' resistance of the following straight tines. Often the straight tine is operated in a raked mode (about 10 degrees forwards) rather than in an upright stance to promote decompaction by creating uplift and also to reduce drag.

O.13 Straight tines (leg) should have a wedge foot (**Figure O.2**) at the base to reduce drag, aid penetration and assist with the upward displacement of the soil and shattering effect.

O.14 There are two forms of straight tines: those with and those without wings (**Figure O.2**). Wings of 250-400mm total span (outer tip to outer tip) are welded either side of the tine leg or foot at angle 20-30 degrees. This is to promote upward displacement and lateral shatter, but also has the effect of significantly increasing drag. Straight tines without wings will require either more overlapping passes or closer spaced tines (the closer spacing will increase drag).

O.15 There are two critical dimensions which determine the potential effectiveness of the tines and hence the ripping operation are: i) Tine length (which determines the potential depth of decompaction); ii) Tine thickness (which determines the potential amount of heave and therefore shatter and decompaction). The achievement of the potential of the ripping tools is dependent on the moisture content of the soil/formation material (it must be dry enough to shatter otherwise the soil material simply deforms around the tool).

O.16 The length of the tine is the most common limiting dimension of the tool. The length of the tine from the heel of the foot to the base of the tool bar/carrier less 200/250mm or 30%, whichever is the lesser, is the potential maximum effective ripping depth of the tine (**Figure O.3**). This is to allow for upward displacement of the soil as the tool is drawn

through the profile. Without this allowance the soil heave will rise to or above the tool bar and increase drag and reduce the decompaction achieved (**Figure O.3**), cause compaction, overheat the bulldozer hydraulics etc.

O.17 The most commonly used tines of between 300-700mm below the tool bar have maximum effective depths of about 150-500mm (Box O.6).

O.18 Longer tines can be provided but these may cause problems with mobility of the bulldozer unit. One exception is the British Coal specification SIMBA MK IV Ripper with 1.2m carrier borne tines which has a potential effective depth of 900mm.

O.19 The width of the tine (front to back) co-determines the potential effective ripping/decompaction depth, with a ratio of 5 times the width of the tine (**Figure O.2**). Typically, the width of the tine is 300-400mm, giving a potential effective depth of 1500-2000mm, which operationally is not usually the limiting factor. The thickness and width of the tine used is usually determined by other factors, the mechanical stresses imposed by the work undertaken (i.e. its strength) and the slot dimensions in the tool bar carrier.

Box O.6 - Allowance for Soil Heave

Length of tine below tool bar mm	Potential maximum effective length mm
200	100
300	150
400	200
500	300
600	400
700	500

O.20 The thickness of the tine (typically 40-80mm) contributes significantly to its strength but also to its drag. The tine should have a welded wear plate on the leading edge to reduce wear, as should the

leading edge of the attached wings (**Figure O.2**).

O.21 The minimum number of tines must be two, each following the mid-point of the tracks of the bulldozer unit (**Figure O.4**). Generally, the most common configuration is three with a tine central to the bulldozer unit. The tines may be arranged in a straight line or as a triangle where the central tine is set further forward to reduce drag. The tines may or may not have wings, often the central tine may be without wings to reduce drag. Three winged tines are likely to be required where only single passes are made. Straight tines without wings are often more appropriate where there are significant damaging obstructions and where soils are excessively stony.

O.22 Mixed combinations of curved tines leading straight tines (as a double beam configuration) are an alternative and can potentially achieve more effective lateral shatter.

Decompaction Operations

O.23 Ripping to decompact materials must only to be undertaken when the soils are dry enough to shatter (i.e. not in a plastic condition) and must be suspended before the soil become plastic. Ripping should only be undertaken in dry weather and is to be suspended when the tractor unit loses traction/ weaves under normal operating conditions. If the soils are inherently wet consideration should be given to deep ripping later following the establishment of a crop to dry out the upper horizons; this may require several successive years of treatment to progressively decompact the profile.

O.24 The tines are to be drawn through the basal/formation or soil layer at the required depth according to the decompaction strategy and capability of the bulldozer and towed/fixed equipment. The tines are to be drawn at sufficient and constant speed, and at their optimum angle (rake) to achieve maximum heave with the least drag, and without track slippage or the bulldozer unit 'weaving'.

O.25 The ripping is only to be undertaken along one axis and usually at an orientation to promote down-slope drainage (see Box O.7), but never crosswise

or across slope unless it is specifically in the SRMP to retain water (as is the practice in dry climates). When ripping is down slope on steep gradients, the machinery is to travel back only on unripped ground.

O.26 The ripping must achieve the required depth in the first pass without the heave rising above the base of the tool bar (Figure O.3), the tine is to enter to its full depth on the first pass and all subsequent passes. The area should not be ripped to a shallow depth first and then re-ripped to a greater depth. However, in some cases and on the basal layer this may be unavoidable in the first pass in order to 'break' ground and reduce resistance to be able to achieve the required penetration. Headlands are to be ripped first to enable quick and full penetration of the tines; this is essential at the base of slopes. Ripping must extend into and out of the sides of existing ditches or if installed later the ditches are to be cut across the lower rip-lines.

Box O.7 – Subsoil 'Piping' Caused by Ripping

Particularly with sandy soils, ripping up/down slope can facilitate the creation of subsurface 'pipes' through the preferential drainage. These can lead to 'soil busts' in wet weather and local collapses/ washouts. To minimize this, either cross slope grips or drains can be installed.

O.27 Where the final profile thickness is equivalent to or less than the effective depth of the tine, the ripping operation can be undertaken after all the horizon(s) have been laid (**Figure O.1b**), except where it is necessary for stones or non-soil debris to be removed.

O.28 Where the profile thickness exceeds the effective depth of the tine, the profile must be ripped in a sequence of successive layers. The ripping is to be undertaken sequentially following the placement of each layer and before the next layer can be laid. This usually takes place after the placement of each horizon (ie lower subsoil, upper subsoil and topsoil) (**Figure O.1b**). If the proposed horizon thickness exceeds the effective depth of the ripper tine, then the soil horizon needs to be laid in sub-layers, with

each of these being ripped to the required depth before the next is laid.

O.29 In the ripping of successive replaced horizons/layers, allowance must be given to recompaction caused in the lower layers by the laying and spreading of the soil by bulldozers, and dump trucks transporting stones and damaging materials for disposal. The allowance necessary depends on the soil type and moisture content. For dump trucks, bulldozers with narrow tracks and large excavators, recompaction to 400-600mm should be allowed for in specifying the thickness of the next layer of soil to be placed and its decompaction. A minimum of 300mm should be allowed for bulldozers with standard tracks and as a precaution the same for wide tracked machines. The recompacted soil layer must be decompacted along with the thickness of the new layer laid. This requires the depth of decompaction of the next layer to include the thickness of the recompacted soil layers. The thickness of the new layer that can be laid over the recompacted layer(s) will be governed by the potential effective depth of the tine. Hence, after the laying and decompaction of the first soil layer, subsequent soil layers will have to be laid at shallower thickness (**Figure O.3**).

O.30 The final decompaction of the topsoil layer should be to the full effective depth of the tine.

O.31 In carrying out the ripping operation, each successive pass is to overlap, with the tine on the ripped side bisecting the pass of the outer and central tine of the previous pass (**Figure O.4**). Where full depth or lateral consistency of decompaction is not achieved, the overlap should be increased.

O.32 The degree and consistency of loosened soil must be checked as the ripping is taking place, especially across the junctions between laid strips of soil (which may require inspection by pits). Routine qualitative assessment can be made with a 15mm diameter steel probe with a blunt convex end.

O.33 The probe is pressed in soils at 150mm intervals along a number of transects across the line of ripping, and the depth to penetration and feel

of resistance recorded (**Figure O.5**). Alternatively, more sophisticated (recording) soil penetrometers may be used. Both methods should only be used in conjunction with a method of on-site 'calibration' of compactness; this is essential as soil water content and stoniness have a major influence on interpretation.

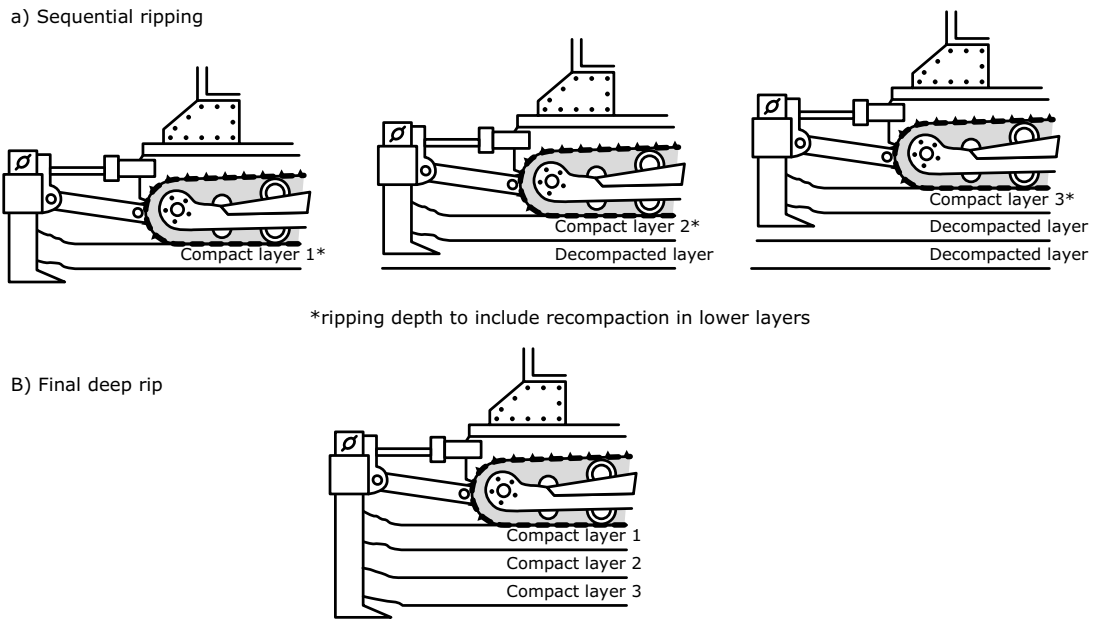

Figure O.1: Decompaction by bulldozer drawn tines.

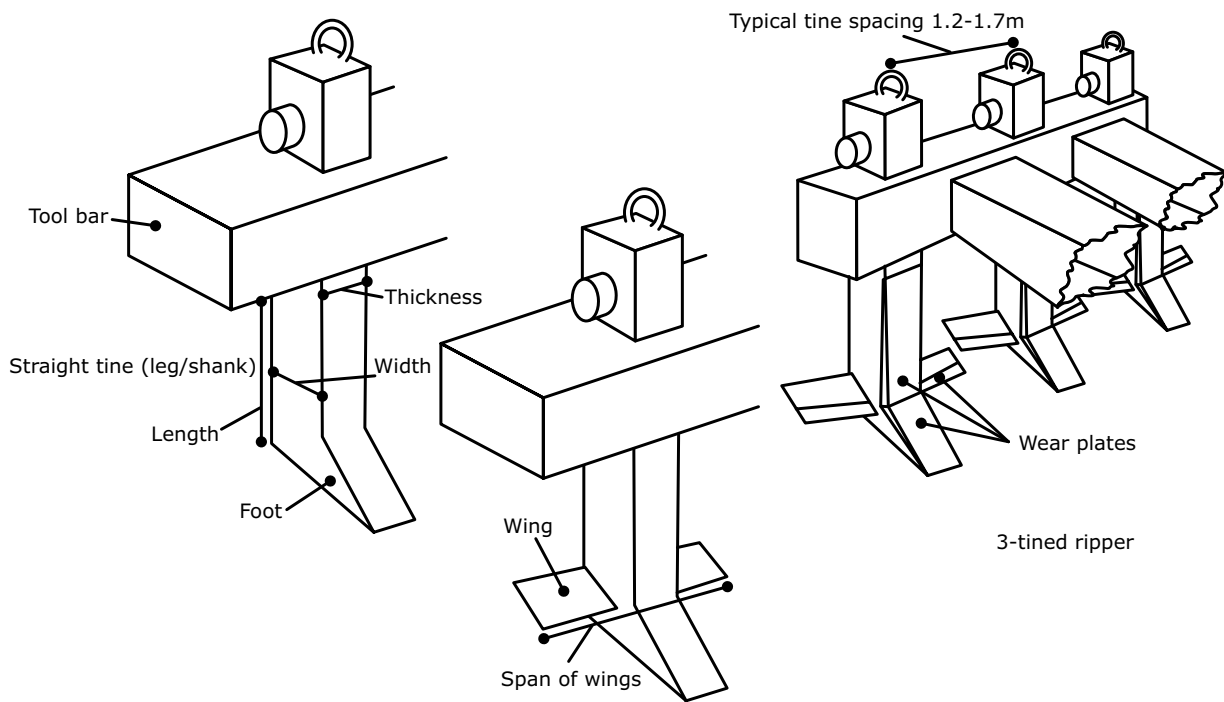
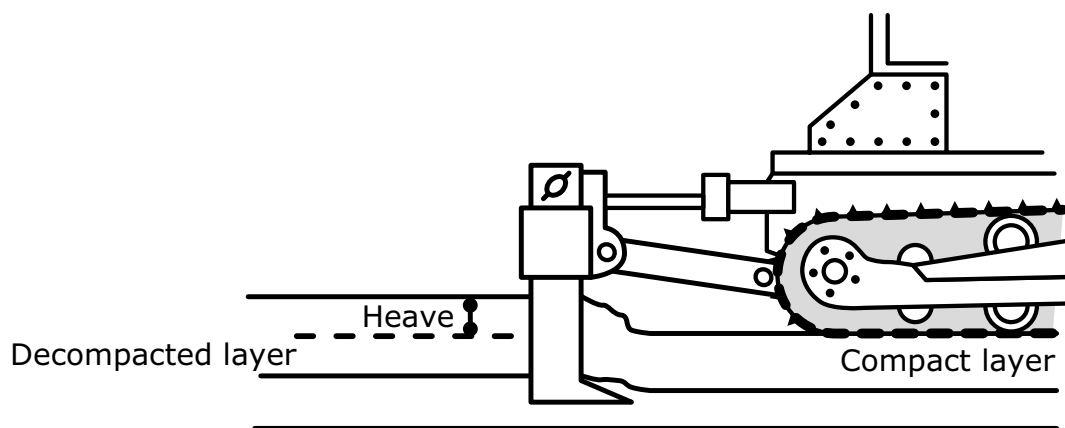
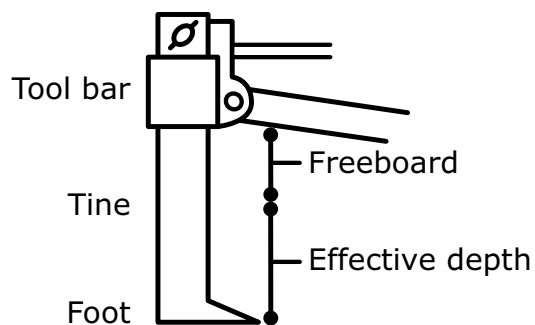

Figure O.2: Features and critical dimensions of bulldozer drawn tines.



Heave = freeboard required below tool bar



Calculation of effective depth of tine of 300mm width & 900mm in length below tool bar:

- i) potential maximum depth of decompaction is 1500mm with tine of 300mm width and 900mm with tine of 900mm length
- ii) potential effective operating depth for first soil layer is $900 - 200$ (freeboard) = 700mm
- iii) potential effective operating depth subsequent soil layer is $900 - (200 + 300$ [eg depth of recompacted lower material]) = 400mm

Figure O.3: Effective decompaction depth by tines.

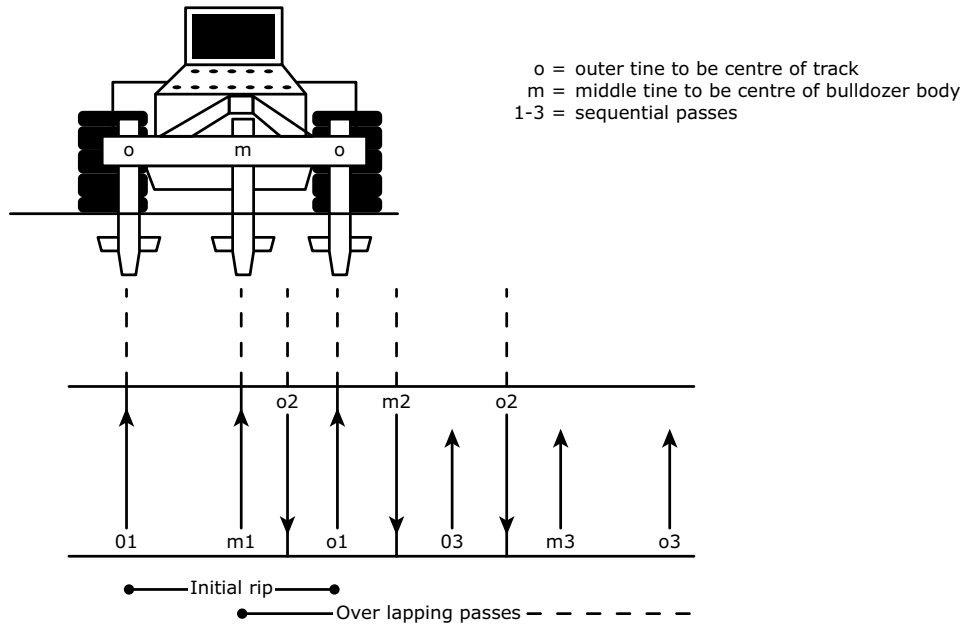

Figure O.4: Decompaction by overlapping passes of bulldozer drawn tines.

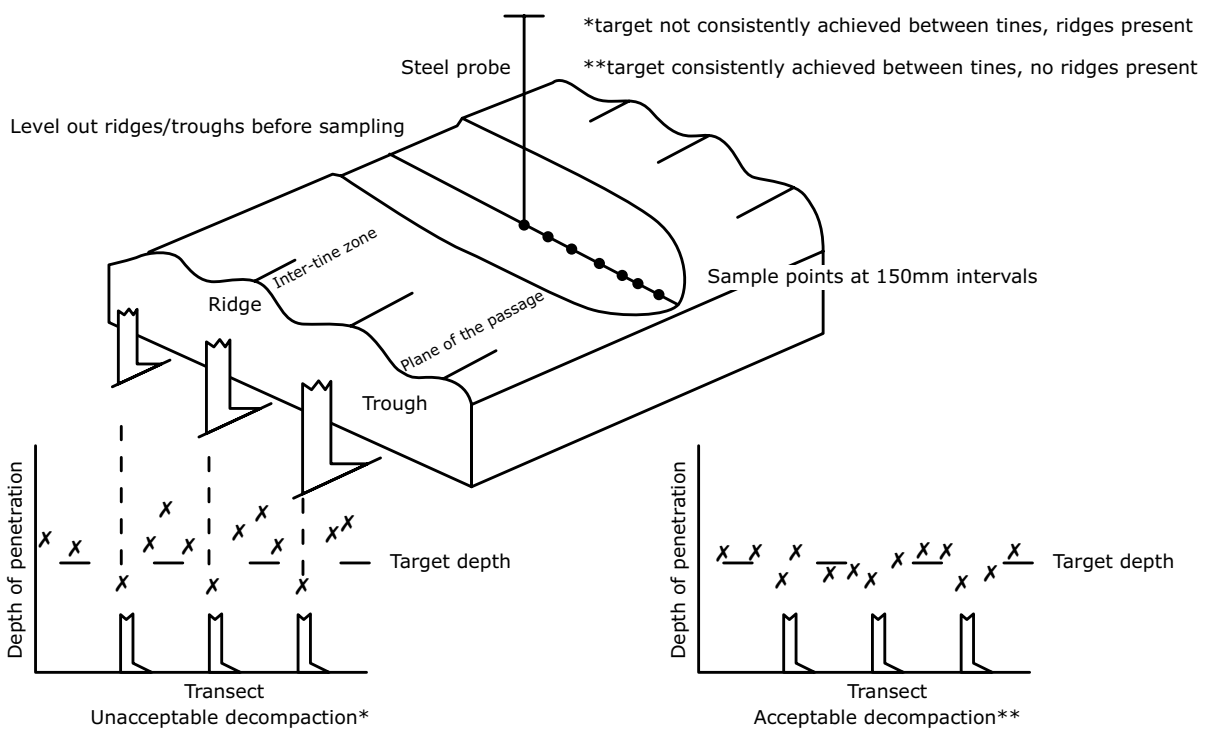

Figure O.5: Assessment of decompaction achieved.



Annex D

Outline Site Resources and Waste Management Plan



Botley West Solar Farm

Outline Code of Construction Practice Annex

Outline Site Resources and Waste Management Plan

08 November 2024

Approval for issue

Jonathan Alsop

8 November 2024

The report has been prepared for the exclusive use and benefit of the Applicant and solely for the purpose for which it is provided. Unless otherwise agreed in writing by RPS Group Plc, any of its subsidiaries, or a related entity (collectively 'RPS') no part of this report should be reproduced, distributed or communicated to any third party. RPS does not accept any liability if this report is used for an alternative purpose from which it is intended, nor to any third party in respect of this report. The report does not account for any changes relating to the subject matter of the report, or any legislative or regulatory changes that have occurred since the report was produced and that may affect the report.

The report has been prepared using the information provided to RPS by its client, or others on behalf of its client. To the fullest extent permitted by law, RPS shall not be liable for any loss or damage suffered by the client arising from fraud, misrepresentation, withholding of information material relevant to the report or required by RPS, or other default relating to such information, whether on the client's part or that of the other information sources, unless such fraud, misrepresentation, withholding or such other default is evident to RPS without further enquiry. It is expressly stated that no independent verification of any documents or information supplied by the client or others on behalf of the client has been made. The report shall be used for general information only.

Prepared by:

RPS
20 Western Avenue,
Milton Park, Abingdon,
Oxfordshire, OX14 4SH
United Kingdom

Prepared for:

Photovolt Development Partners GmbH,
on behalf of SolarFive Ltd.

Contents

1	OUTLINE SITE RESOURCES AND WASTE MANAGEMENT PLAN.....	1
1.1	Introduction	1
1.2	Purpose of the Outline Site Waste Management Plan	1
1.3	Scope of this Plan	2
1.4	Regulatory Framework and Guidance	3
1.5	Implementation of the Site Resources and Waste Management Plan	5
1.6	Audit, Monitor and Review	7
1.7	Key Obligations	7
1.8	Principles of the Site Waste Management Plan.....	8
1.9	Management of Waste and Resources from the Project	9
1.10	Identification of Waste Arisings	12
1.11	References	14

Figures

Figure 1.1:	Waste hierarchy	9
-------------	-----------------------	---

Annexes

Annex A	Template for Site Waste Management Plan	15
Annex B	Template for Resource Management Plan	25

Glossary

Term	Meaning
The Applicant	SolarFive Ltd
The Project	Botley West Solar Farm
Code of Construction Practice	A document detailing the overarching principles of construction, construction related environmental management measures, pollution prevention measures, and monitoring processes
Site Waste Management Plan	A Plan setting out how wastes and consumption of key resources will be minimised and managed during the construction process. The Plan will set targets for diverting waste from landfill; during construction the Plan will be updated as waste is moved from the types and quantities of waste predicted to be generated

Abbreviations

Abbreviation	Meaning
CoCP	Code of Construction Practice
DCO	Development Consent Order
EIA	Environmental Impact Assessment
ES	Environmental Statement
NGET	National Grid Electricity Transmission
NPPF	National Planning Policy Framework
NPS	National Policy Statement
NSIP	Nationally Significant Infrastructure Project
PINS	The Planning Inspectorate
PV	Photovoltaic
PVDP	Photovolt Development Partners GmbH
SRWMP	Site Resources and Waste Management Plan

Units

Unit	Description
%	Percentage
km ²	Square kilometres
kWh	Kilowatt hour
MW	Megawatt
MWe	Megawatt electrical
MWh	Megawatt hour

1 OUTLINE SITE RESOURCES AND WASTE MANAGEMENT PLAN

1.1 Introduction

Overview

1.1.1 This Outline Site Resources and Waste Management Plan (SRWMP) is provided as an appendix to the Outline Code of Construction Practice (CoCP). It sets out the key management measures that will be implemented during the construction phase of the Botley West Solar Farm (referred to as the 'Project').

1.1.2 The Plan seeks to manage potential waste impacts that occur from the construction of the Project. The main construction activities are set out below:

- Site preparation
- Establishment of the perimeter fence and main construction compounds(s)
- Delivery of construction material, plant and equipment to site
- Solar PV module and associated infrastructure construction, comprising:
 - Delivery of components to site
 - Erection of module mounting structures
 - Installation of modules and Power Converter Stations (PCS)
 - Trenching and installation of electric cabling
 - Transformer foundation excavation and construction
 - Testing and commissioning
- Landscaping and other environmental enhancements

1.1.3 In addition, the Outline SRWMP also considers the temporary construction compounds, landscaping and mitigation areas, and accesses required to support the construction of the Project. There will be four main temporary construction compounds: one in the Northern Site Area, two in the Central Site Area and one in the Southern Site Area (see Temporary Facilities Plan (doc. ref)). In addition, there will be temporary field compounds as described in Volume 1, Chapter 6: Project Description. The landscaping and ecology mitigation areas are shown on the Outline Landscape and Ecology Management Plan.

1.1.4 The relevant waste planning authority for the Project is Oxfordshire County Council.

1.2 Purpose of the Outline Site Waste Management Plan

1.2.1 The draft Development Consent Order (DCO) (EN010147/APP/3.1)) includes a requirement for the preparation of a final Code of Construction Practice (CoCP). The final CoCP(s) will be supported by a series of management plans including a SRWMP(s) (as part of the final CoCP), which must be submitted to

and approved by the relevant planning authority prior to the commencement of construction.

1.2.2 The purpose of this Outline SRWMP is to:

- demonstrate how waste and the use of resources will be considered during the construction phase of the Project ;
- ensure compliance with legal requirements for managing waste, including the completion of duty of care paperwork;
- set out measures for managing waste and resources during construction to meet legislative and policy requirements, including the waste hierarchy principle; and
- identify the roles and responsibilities for implementing the measures in the plan.

1.2.3 This is an outline document that is based on the design set out in the Project Description (see Volume 1, Chapter 6 **[EN010147/APP/6.3]**).

1.2.4 The Outline SRWMP should be read in conjunction with the Outline CoCP **[EN010147/APP/7.6.1]** and its supporting appendices.

1.3 Scope of this Plan

1.3.1 The scope of this Outline SRWMP applies to the site preparation and construction activities of the Project .

1.3.2 Site preparation will be undertaken prior to the commencement of construction. These works comprise the following:

- Pre-construction archaeological investigations;
- Early planting or landscaping works, where appropriate;
- Ecological and archaeological mitigation;
- Environmental surveys and monitoring;
- Site clearance (including vegetation clearance and site levelling)
- Investigations for the purpose of assessing ground conditions such as:
 - pre-entry soil surveys; and
 - drainage surveys.
- Remedial work in respect of any contamination or other adverse ground conditions;
- The diversion of existing services and the laying of temporary services;
- The diversion or undergrounding of overhead cabling;
- Road improvements;
- Site security works;
- Establishing compounds and the erection of temporary hardstanding, buildings (e.g. welfare facilities), structures or enclosures;
- Creation of site accesses;
- Temporary display of site notices and site advertisements; and

- Receipt and erection of construction plant and equipment.

1.3.3 The Site preparation works listed in **paragraph 1.3.2** above will be carried in accordance with the measures set out in this Outline SRWMP as part of the CoCP, which is secured as a requirement of the DCO.

1.3.4 The final SRWMP(s) will be substantially in accordance with the principles established in the Outline SRWMP and will be agreed with the relevant authorities prior to commencing the relevant stage of the works. For the purpose of this plan, the term 'construction' includes all related engineering, construction and restoration activities as authorised by the DCO within the Order Limits.

1.4 Regulatory Framework and Guidance

Definition of Waste

1.4.1 For the purpose of this document the definition of 'waste' is taken from Article 3(1) of the revised European Waste Framework Directive (2008/98/EC), which states that waste is 'any substance or object which the holder discards or intends or is required to discard'.

1.4.2 'Discard' includes the recovery and recycling of a subject or object as well as its disposal. The decision on whether something is discarded must take account of all the circumstances (for example, the nature of the material, how it was produced and how it will be used) and have regard to the aims of the Waste Framework Directive, which is '*the protection of human health and the environment against harmful effects caused by the collection, transport, treatment, storage and tipping of waste*'.

1.4.3 Guidance on the interpretation of the Waste Framework Directive definition of waste is taken from the Environment Agency's published guidance 'Check if your material is waste' (Environment Agency 2024), which provides a practical guide to help organisations make decisions about whether a material is a waste or not.

1.4.4 The document also takes into account CL:AIRE's Definition of Waste: Development Industry Code of Practice (CL:AIRE 2011). The CoP sets out good practice for the development industry to use when:

- 'assessing on a site-specific basis whether excavated materials are classified as waste or not; and
- determining on a site-specific basis when treated excavated waste can cease to be waste for a particular use'.

1.4.5 The Code of Practice will be taken into account by the Environment Agency in deciding whether to regulate materials as waste. If materials are dealt with in accordance with the Code of Practice, the Environment Agency considers that those materials are unlikely to be waste if they are used for the purpose of 'land development'.

1.4.6 The scope of the Code of Practice relates to 'excavated materials' which include:

- soil, both topsoil and subsoil, parent material and underlying geology;

- ground based infrastructure that is capable of reuse within earthworks projects (e.g., road base, concrete floors);
- made ground; and
- stockpiled excavated materials that include the above.

Legislation and Guidance

- 1.4.7 The UK legislative framework for the management of construction wastes comprises the following:
- Environmental Protection Act 1990.
 - Environment Act 2021.
 - Hazardous Waste (England and Wales) Regulations 2005 (as amended).
 - Revised Waste Framework Directive (2008/98/EC).
 - Landfill Directive (1999/31/EC).
 - Environmental Permitting (England and Wales) Regulations 2016 (as amended).
 - Waste Management (England and Wales) Regulations 2006.
 - Waste (England and Wales) Regulations 2011 (as amended).
 - Waste (Circular Economy) (Amendment) Regulations 2020.
 - Technical guidance MW3: waste Classification – Guidance on the classification and assessment of waste (Environment Agency, 2014) (as updated in 2018).
 - Waste Duty of Care: Code of Practice (Defra, 2016).
- 1.4.8 Part II of the Environment Protection Act 1990 contains a prohibition on the unauthorised deposit of waste on land, a duty of care in relation to the transfer of waste, and defines, for the purpose of the Act, construction and demolition and commercial and industrial wastes.
- 1.4.9 The framework of waste management legislation in the UK is currently shaped by the Waste (England and Wales) Regulations 2011 (as amended). These regulations require all businesses and organisations that produce waste to take all reasonable measures to prevent waste, to apply the waste hierarchy (refer to **section 1.8** of this document) when transferring waste using the definitions in Article 3 of the Waste Framework Directive 2008/98/EC and include a declaration on their waste transfer notes or consignment notes to that effect. Standard Industry Classification (SIC) Codes (Companies House, 2018) of the waste producer will also be provided in the waste transfer note. The SIC is a system for classifying industries by a five-digit code.
- 1.4.10 The Waste Regulations 2011 (as amended) also require that any organisation which collects waste paper, metal, plastic or glass must do so using separate collections to facilitate or improve recovery of these materials and where it is technically, environmentally and economically practicable.
- 1.4.11 The Environment Act 2021 provides a legal framework for environmental governance and makes specific provision for the improvement of the environment. Part 3 makes provisions for managing waste and producer

responsibility including a revised extended producer responsibility scheme and powers to regulate resource efficiency information across a wider range of products.

- 1.4.12 Hazardous Waste (England and Wales) Regulations 2005 (as amended) set out the requirements for controlling and tracking the movement of hazardous waste and bans the mixing of different types of waste. Under the Regulations 'mixing' includes mixing of different categories of hazardous waste, non-hazardous wastes or any other substance or material.
- 1.4.13 The Waste (Circular Economy) (Amendment) Regulations 2020 amends legislation that transposed waste-related EU Directives (including the Waste Framework Directive 2008/98/EU) and makes the legislative changes required to transpose the 2020 Circular Economy Package (CEP) measures. The CEP identifies steps for the reduction of waste and establishes a long-term plan for waste management and recycling.
- 1.4.14 National policy documents (e.g. National Policy Statements), strategies and initiatives (e.g. the Resources and Waste Strategy (2018) and Waste Management Plan (2021)) are summarised in the Waste and Resources Chapter of the Environmental Statement (Volume 1, Chapter 18 [EN010147/APP/6.3]).

1.5 Implementation of the Site Resources and Waste Management Plan

Overview

- 1.5.1 Although the construction project team has not been appointed at the time of writing this plan, the key roles and associated responsibilities with regard to this Outline SRWMP are outlined below. The Construction (Design and Management) Regulations 2015 also identify the legal duties, responsibilities and obligations of the major roles within the construction team.

Roles and Responsibilities

Applicant

- 1.5.2 The Applicant will be responsible for the following:
- Ensuring that the SRWMP(s) is implemented effectively.
 - Giving necessary direction to contractors (for example, setting contractual obligations).
 - Reviewing, revising and refining the final SRWMP(s), where necessary, in conjunction with the Principal Contractor.

Principal Contractor

- 1.5.3 The Principal Contractor will be appointed by the Applicant and has the overall responsibility for the following:
- Updating and delivering the final SRWMP(s) on behalf of the Applicant.

- Working with the Applicant to identify opportunities to divert waste from landfill.
- Ensuring all procedures in the final SRWMP(s) are followed.
- Ensuring any additional contractors are suitably qualified and experienced in implementing the measures within the final SRWMP(s). These measures will be contained within the terms of contracts to ensure understanding and accountability.
- Ensuring that all legal and contractual requirements relating to the SRWMP(s) are met by ensuring adequate plans/procedures, licences and certificates are in place, and that they can be achieved.
- Ensuring that adequate waste collection systems are in place including frequent collections and that waste carriers are registered.
- Establish procedures for the regular review and recording of the quality of the works as part of its Quality Management System.
- Notify the Environment Agency if construction activities are anticipated to generate more than 500 kg of hazardous waste within a 12-month period.
- Maintain records relevant to the final SWMP(s).
- Monitor compliance with the forecasts and measures in the final SRWMP(s) by regularly undertaking audits (at least once every three months) and preparing a report for management record. A review will be undertaken at least every six months or earlier where there has been a change to the works or relevant regulations.

Contractors/Sub-contractors

- 1.5.4 Contractors and sub-contractors will be responsible for carrying out the waste management tasks in the final SRWMP(s) in conjunction with the Principal Contractor. All contractors producing construction waste will be responsible for ensuring their waste is managed in accordance with the legislative requirements set out **section 1.4.7** and the waste duty of care (set out in **section 1.7**). All waste carriers used to transport construction waste from the Project will be registered carriers with the Environment Agency. Contractors will also have to demonstrate how they have minimised waste and that they have considered opportunities to reuse or recycle their waste.

Training

- 1.5.5 Training will be provided by the Principal Contractor to ensure that all relevant members of the construction teams, including sub-contractors' personnel receive focused SRWMP training to ensure their competence in carrying out their duties.
- 1.5.6 Any training related to the SRWMP will be additional to the mandatory training requirements relating to site Health and Safety.

Environmental Induction

- 1.5.7 A general site induction will be given to introduce all site personnel to the environmental issues connected with the final SRWMP(s) and important

environmental controls associated with the day-to-day construction activities (e.g. waste storage arrangements, appropriate waste segregation).

- 1.5.8 Construction staff will be briefed on the final SRWMP(s) and the waste management procedures to be followed.

Toolbox Talks and Method Statement Briefings

- 1.5.9 Toolbox talks and method statement briefings will be given to all site personnel as work proceeds and will cover the types of wastes produced at each key build stage, and the final SRWMP(s) controls related to specific activities undertaken during the works (for example, recycling of concrete). A register of toolbox talks and method statement briefing attendance will be maintained on site.

Training Records

- 1.5.10 All training records will be maintained and filed on site by the Principal Contractor. The records will include the content of the courses (induction and toolbox training), record of attendance and schedule of review.

1.6 Audit, Monitor and Review

Site Inspection

- 1.6.1 Regular inspections of the construction works will be undertaken by the Principal Contractor (or appropriately trained member of the construction staff) to ensure the continued compliance of site operations with the provisions of the final SRWMP(s) and control measures outlined in relevant method statements.

Monitoring of the Final Site Resources and Waste Management Plan(s)

- 1.6.2 Appropriate duty of care paperwork for the movements of waste (for example, waste transfer notes) will be retained on site. Volumes (m³ or tonnes) and waste types will be recorded for all wastes sent for reprocessing, recycling or disposal. Records will also be kept of waste re-used/recycled on site.
- 1.6.3 A separate SWMP close out report will be compiled by the Principal Contractor at the end of the construction process that summarises performance of the project against the targets set in the final SRWMP(s). The report will identify any deviations from the final SMWP(s).

1.7 Key Obligations

Duty of Care

- 1.7.1 A key requirement of section 34 of the Environmental Protection Act 1990 is that the waste producer is responsible for ensuring that their waste is collected by an appropriately licensed waste carrier and managed at a suitably licensed facility. These requirements are set out in the 'Waste Duty of Care: Code of Practice' (Defra 2016). To meet these requirements, waste materials arising

from construction will only be transported by waste carriers and hazardous waste carriers holding a valid registration with the Environment Agency. Each consignment of waste removed from the construction site will be accompanied by a waste transfer note (or hazardous waste consignment note as appropriate), which correctly describes the waste using the European Waste Catalogue code, identifies the waste carrier and where the waste will be transported to.

- 1.7.2 Requirements for transferring waste and registered waste carriers are set out in Part 8 and 9 of the Waste (England and Wales) Regulations 2011. The waste will only be transferred to facilities that have the benefit of a registered waste exemption, or an environmental permit. Periodic audits will be undertaken of these facilities.

Pre-treatment of Wastes

- 1.7.3 Inert, non-hazardous and hazardous wastes destined to be landfilled will be pre-treated prior to disposal in accordance with the EU Landfill Directive (1999/31/EC). Treatment can comprise physical, thermal, chemical or biological processes providing that they change the characteristics of the waste in order to reduce its volume or hazardous nature or to facilitate its handling or recovery.

1.8 Principles of the Site Waste Management Plan

Waste Hierarchy

- 1.8.1 The waste hierarchy ranks waste management options according to what is best for the environment (see **Figure 1.1**). It gives top place to waste prevention. When waste has been generated, priority is given to preparing it for re-use, then recycling, then recovery, and last of all disposal (for example, landfill). The waste hierarchy is a key element of sustainable waste management and following the hierarchy is a legal requirement of the Waste (England and Wales) Regulations 2011 (as amended).
- 1.8.2 The Department for Environment, Food & Rural Affairs (Defra) (2011) has published guidance on how the waste hierarchy should be applied to a range of common wastes. It highlights the importance of prioritising waste management practices using a specified order to minimise any potential environmental impacts. The guidance states that for most materials the waste hierarchy ranking applies. However, the evidence suggests that for some materials, the preferred waste management option (i.e. with the lowest environmental impact) does not follow the waste hierarchy order. This is true for lower grades of wood, where energy recovery options are more suitable than recycling.
- 1.8.3 All waste generated by the Project will be managed in accordance with the waste hierarchy unless it can be demonstrated that an alternative option lower down the hierarchy is the best overall environmental outcome (for example, waste wood is often used for biomass heat recovery rather than being recycled).

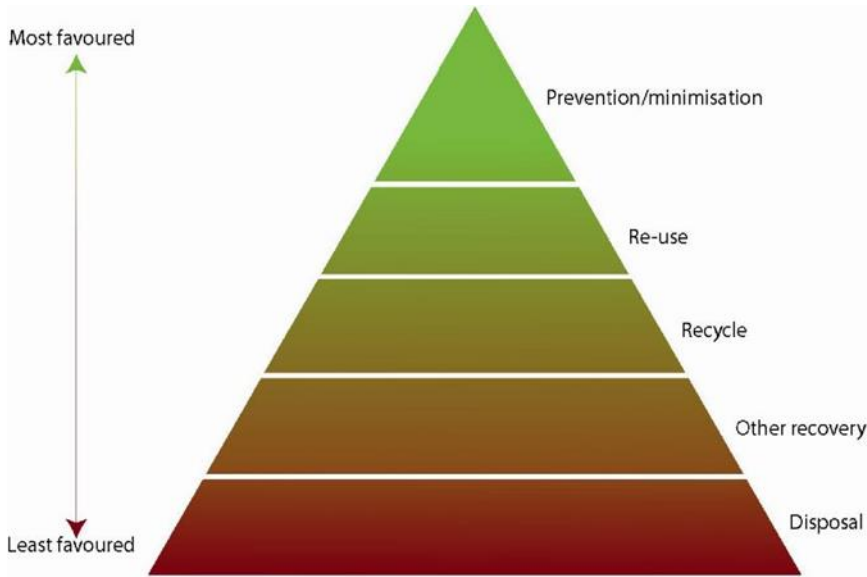

Figure 1.1: Waste hierarchy

Proximity Principle

1.8.4 The proximity principle is set out in Article 16 of the Waste Framework Directive (2008/98/EC) and transposed under regulation 18 of the Waste (England and Wales) Regulations 2011 (as amended). Where possible, construction waste from the Project will be managed at waste management sites close to the point of generation, subject to the waste management site having the relevant environmental permit and planning consent.

1.9 Management of Waste and Resources from the Project

Prevention

1.9.1 Waste can be minimised during the design stage, including the following measures:

- using prefabricated materials for on-site assembly;
- buildings/structures designed to standard dimensions of blocks or frames to avoid offcuts;
- topsoil and subsoil generated from the site preparation works at the converter stations will be retained on site where possible to be used in the site restoration and landscaping; and
- internal materials and fittings will be pre-cut to reduce the need for site cutting.

1.9.2 Waste will also be minimised by improving wastage rates when ordering materials. Waste allowances are generally included within material orders to take into account design waste and construction process waste. These waste allowances are often generic and not project specific and therefore, run the risk of being inaccurate. This can lead to a surplus of materials, which typically ends up being discarded (i.e., waste). A system will be put in place to enable the accurate estimates of material requirements (and waste allowances) at the detailed design stage.

- 1.9.3 On appointment of the Principal Contractor, the purchasing requirements will be discussed with the site manager(s) to identify priorities and review the quotations received. Materials will be checked against the material specifications as part of the quality control system.
- 1.9.4 Where possible, hazardous materials will be substituted for less hazardous alternatives.
- 1.9.5 Waste minimisation measures will be implemented by the Principal Contractor and site manager(s) during construction in order to achieve the waste allowance targets. These measures include:
- subsoil and topsoil generated from the construction of the cable corridors (HVAC and HVDC) will be used as backfill to reinstate the trenches;
 - a logistic system which allows 'just-in-time' deliveries to minimise the length of time materials are stored on-site and co-ordinate with other trades;
 - providing suitable and secure storage for materials where 'just-in-time' deliveries cannot be set up;
 - mechanical systems and machinery will be considered for moving materials to reduce the risk of damage; and
 - programming and monitoring construction activities to avoid overlap of incompatible trades working in the same area and to reduce the potential for waste to be generated from replacing damaged work.

Preparing for Re-use

- 1.9.6 The installation of the cable corridor will require the construction of a temporary haul road and temporary construction compounds (including landfall and Converter Site).
- 1.9.7 On completion of the cable installation works, the haul road will be dismantled. Where possible, opportunities to re-use the aggregate to construct other elements of the Project will be investigated. Landowners may also be given the option of re-using the stone on their land for maintaining farm tracks.
- 1.9.8 Alternatively, the aggregate will be transported to a local waste management facility for re-use on construction projects elsewhere. Opportunities to reduce packaging or implement take-back schemes for packaging and unused materials will also be discussed with the suppliers. For example, the cable drums will be returned to suppliers for re-use.

Recycling

- 1.9.9 The Principal Contractor will consider the use of recycled materials where possible, subject to cost and availability (for example, recycled aggregate and secondary aggregates for use in concrete, or granular fill).
- 1.9.10 During the construction phase, wastes will be segregated into waste types to facilitate off-site recycling (for example, metals, wood, plastic). The layout of the construction site has been designed to allow sufficient space for separate containers of key waste materials to be stored. These containers will be clearly labelled and construction staff will be given training on waste segregation.

- 1.9.11 Green waste generated during site preparation works will be composted off-site. Opportunities will be investigated to retain woody material on site for ecological habitats, however this will be subject to agreement with landowners.
- 1.9.12 A responsible approach will be taken in managing resources in the construction phase. Specification of construction materials will follow best practice in selecting material that is responsibly sourced with low environmental impact and maximising efficient use of resources. All timber products will be responsibly sourced from reputable suppliers as per the UK Government's Timber procurement policy (Defra, 2013).

Disposal

- 1.9.13 All waste that cannot be reused, recycled or recovered will be collected by the licensed waste management contractor and disposed of at a permitted site suitable for the type of waste. Burning of surplus material or material arising from the site construction will not be permitted.

Storage of Waste

- 1.9.14 Dedicated waste storage areas will be provided within each temporary construction compound. Each skip/container will be clearly marked to indicate the intended contents and will be suitable for the storage of the specified contents. All skips/containers will be covered to prevent the escape of waste by wind blow or vandalism. If liquid waste is being stored, an appropriate bund and drip pans will be in place.
- 1.9.15 Storage areas will be located away from potential contaminant pathways such as drains, and excavations and trenches. Any hazardous waste will be stored safely in a designated area away from non-hazardous and inert wastes and labelled accordingly.

Register Carriers

- 1.9.16 Construction waste generated will only be transported by companies registered with the Environment Agency and with valid waste carrier licences as required by the 'Waste Duty of Care Code of Practice' and legislation (i.e., Environmental Protection Act section 34 and the Waste (England and Wales) Regulations 2011).

Setting Targets for Resource Efficiency and to Divert Waste from Landfill

- 1.9.17 Resource efficiency targets will be set during the detailed designed stage for specific materials. This will include targets for alternative aggregates (comprising secondary aggregates and recycled aggregates) and recycled content materials such as steel reinforcement subject to the appropriate specifications for the Project being met.
- 1.9.18 The Applicant will aim to achieve the following target for construction waste (excluding spoil) generated by the Project :

- Divert 80% (by weight) of non-hazardous construction waste (i.e. non-demolition waste) from landfill.

- 1.9.19 Diversion from landfill will be achieved through a combination of on-site and off-site reuse, recycling and recovery opportunities subject to the construction programme and available capacity on the site.
- 1.9.20 The targets exceed the target set by the Waste (England and Wales) Regulations 2011 (as amended), which requires that a minimum of 70% of construction and demolition waste should be prepared for reuse, recycling or other material recovery.
- 1.9.21 Where applicable, further targets will be set during the detailed design stage to reduce, reuse or recycle key waste materials on- and off-site. The targets will be incorporated into the contract specifications with contractors post consent.
- 1.9.22 Non-hazardous excavated spoil will primarily be re-used on the site and managed through the CL:AIRE Code of Practice. The Applicant will aim to maximise re-use of the non-hazardous excavated spoil on site. The remaining material will be taken off site: the Project will aim to divert all of this material from landfill where possible.

1.10 Identification of Waste Arisings

Waste Types

- 1.10.1 At a strategic level, the key waste types generated from the construction of the Proposed Development can be classified as follows:
- **INERT** – wastes that will not cause adverse effects to the environment when disposed of, or do not decompose and they have no potentially hazardous content when deposited in a landfill. Examples of inert wastes are rocks, concrete, mortar, glass, uncontaminated soils and aggregates
 - **NON-HAZARDOUS** – wastes that will decompose when buried resulting in the production of methane and carbon dioxide. Examples of non-hazardous wastes include timber, paper and cardboard
 - **HAZARDOUS** – wastes that are harmful to human health or the environment (for example, causing pollution of watercourses) if they are incorrectly handled, stored, treated or disposed of. Hazardous wastes may have one or more of the following properties: explosive, corrosive, flammable, highly flammable, infectious, oxidising or sensitising.
- 1.10.2 As a requirement of the CEP, the definitions of these waste types have been amended in line with the wording from Article 2(a) of the Landfill Directive.
- 1.10.3 The construction of the Proposed Development is anticipated to generate a number of different waste types. This will include (but is not limited to) wastes contained within the following list of waste categories (also known as waste classification codes, as identified in Environment Agency 2018):
- 17 01 concrete, bricks, tiles and ceramics;
 - 17 02 wood, glass and plastic;
 - 17 03 bituminous mixtures, coal tar and tarred products;

- 17 04 metals (including their alloys);
- 17 05 soil (including excavated soil from contaminated sites), stones and dredging spoil;
- 17 06 insulation materials and asbestos-containing construction materials;
- 17 08 gypsum-based construction material; and
- 17 09 01* construction and demolition wastes containing mercury.

1.10.4 It is noted that a number of sub-categories of wastes are included within the above. The waste codes for each specific waste type will be provided on each waste transfer note that will accompany every movement of waste from construction areas.

Estimated Waste Arisings

1.10.5 The final SRWMP(s) will include waste and resource use forecasts that will be prepared alongside the detailed design process. The final SRWMP(s) will be updated during the construction phase to document progress against waste management forecasts. This will also allow for any changes either to the works or to accommodate new regulatory requirements.

1.10.6 An indicative forecast of key wastes likely to be generated from the construction of the Project provided in Error! Reference source not found. . The list of wastes is not exhaustive and may be extended as the detailed design and construction plan develops after consent.

1.10.7 Prior to construction, the Applicant and Principal Contractor will review and update waste estimates accordingly to reflect changes to detailed design decisions, or construction methodologies. Any updates to the waste estimates will be recorded together with an explanation of the changes.

1.10.8 Once construction is underway, the Principal Contractors will complete Waste Management Data Sheets. These sheets will be updated every time waste is removed from the site and will record the following:

- The types and quantities of waste produced.
- The types and quantities of waste that have been re-used/ recycled/ recovered/ landfilled or otherwise disposed of on or off site.
- The registration number of the waste carrier.
- A copy of or reference to the written description of the waste.
- Details of the site where the waste is taken to and its permit number.

1.10.9 The Principal Contractor will compile waste management data into reports at least every six months to monitor progress toward achieving the targets and corrective action will be taken as required.

1.10.10 On completion of construction, a comparison of the estimated waste arisings and the actual waste management data will be undertaken. Any differences between the estimated and actual waste arisings will be used to assess the effectiveness of the waste minimisation and management measures.

1.11 References

Companies House (2018). Standard Industrial Classification of Economic Activities (SIC). Available at: <https://www.gov.uk/government/publications/standard-industrial-classification-of-economic-activities-sic#:~:text=A%20condensed%20list%20of> (Accessed: September 2024).

Contaminated Land: Applications in Real Environments (CL:AIRE) (2011). The Definition of Waste: Development Industry Code of Practice. London, CL:AIRE.

Department for Environment Food and Rural Affairs (2011). Guidance on applying the Waste Hierarchy. Available at: <https://assets.publishing.service.gov.uk/media/5a795abde5274a2acd18c223/pb13530-waste-hierarchy-guidance.pdf> (Accessed: September 2024).

Department for Environment Food and Rural Affairs (2016). Waste Duty of Care: Code of Practice. Available at: https://assets.publishing.service.gov.uk/media/6274d74bd3bf7f5e3ade6090/Waste_duty_of_care_code_of_practice.pdf (Accessed: September 2024).

Department for Environment, Food and Rural Affairs (2013): Timber Procurement Policy (TPP): prove legality and sustainability. Available online at: <https://www.gov.uk/guidance/timber-procurement-policy-tpp-prove-legality-and-sustainability> (Accessed: September 2024).

Environment Agency (2018). Waste Classification and Assessment: Guidance on the Classification and Assessment of Waste. (Technical Guidance WM3).

Environment Agency (2024). Check if your material is waste. Available at: <https://www.gov.uk/guidance/check-if-your-material-is-waste> (Accessed: September 2024).

Environmental Permitting Regulation (2016). England and Wales. Available at: http://www.legislation.gov.uk/ukxi/2016/1154/pdfs/ukxi_20161154_en.pdf (Accessed: September 2024).

Office for National Statistics (2009). UK Standard Industrial Classification of Economic Activities 2007 (Standard Industry Classification 2007). Structure and Explanatory Notes. Palgrave Macmillan.

Annex A

Template for Site Waste Management Plan

A.1 Waste Minimisation

A.1.1 Decisions taken during the detailed design process to minimise waste will be recorded in the table below.

Table A1.1: Waste Minimisation Measures Template

Approach to designing out waste	Measures to be implemented
Reuse and recovery	
Off site construction	
Materials optimization	
Waste efficient procurement	
Deconstruction and flexibility	

A.2 Waste Forecasts

A.2.1 The Waste Forecast tables and the Waste Estimates Data Sheet will be completed by the Applicant and updated by the Principal Contractor prior to construction to document how waste has been considered with regard to the likely types and quantities of waste to be generated during construction and how they will be managed.

Type of Waste	Estimated Volume/Tonnage	Management Option
Vegetation – site clearance	Low (not significant)	Composting
General waste from welfare facilities at construction compounds	Low (not significant)	Landfill/recycling
Drilling mud (e.g. bentonite)	Low (not significant)	Landfill/recycling
Paints	Low (not significant)	Landfill/recycling
Solvents	Low (not significant)	Landfill/recycling
Chemical storage containers	Low (not significant)	Landfill/recycling
Module packaging		
Pallet wood – for PV module and mounting structure packaging	150,531.42 m ³	Recycling
Corrugated cardboard, plastic wrap and Kraft cardboard – for PV module and mounting structure packaging	16,852.70 m ³	Recycling
Tension straps and spacers	82,686.42 (number)	Recycling
Packaging for other materials		
Mounting frames	10,000 m ³	Recycling
Cable drums		
6 mm ² DC cable drums Mixed wood, plastic, metal	157 tonnes	Re-use – return system
LV cable drums Mixed wood, plastic, metal	50 tonnes	Re-use – return system
Grounding cable drums Mixed wood, plastic, metal	50 tonnes	Re-use – return system
MV cable drums Mixed wood, plastic, metal	10 tonnes	Re-use – return system
HV cable drums Mixed wood, plastic, metal	5 tonnes	Re-use – return system
Excavated material - spoil		
Excavated materials from trenches unusable - elsewhere on site	50,000 m ³	Landfill/recycling
Excavated material from drainage, roads, foundations – unusable elsewhere on site	15,000 m ³	Landfill/recycling
Excavated material – secondary substation		
Excavated material from foundations unsuitable for reuse	100 m ³	Landfill/recycling
Total Excavation Waste	65,100 m ³ (162,750 tonnes)	
Haul roads and compounds		

Type of Waste	Estimated Volume/Tonnage	Management Option
Crushed stone from reinstatement of compounds	5,000 m ³	Crushed on site/recycling off site
Rubber mats	175,347 (number)	Re-use off site (5% retained on site)
Metal mats	17,177 (number)	Re-use off site (5% retained on site)

Project Component:

Waste Category & Type	EWC Code	Reused On Site (m ³)	Reused Off Site (m ³)	Recycled On Site (m ³)	Treatment Required (Y/N & Type)	Recycled Off Site (m ³)	Recovered (On/Off Site) (m ³)	Sent to Permit Exempt Site	Sent to Landfill Site for Disposal
-----------------------	----------	----------------------------------	-----------------------------------	------------------------------------	---------------------------------	-------------------------------------	---	----------------------------	------------------------------------

Sub TOTAL

TOTAL VOLUMES

A.4 Existing local waste management facilities

A.4.1 The existing local waste management infrastructure is set out in the Table below.

Table A4.1: Existing local waste management facilities

Existing Waste Management Facilities within 15 km of the Site						
Ref	Permit	Operator	Site Name	Waste accepted	Capacity	

A.5 Waste Management Data Sheet (to be completed each time waste is removed off site/track reuse on site)

A.5.1 The Waste Management Data Sheet will be completed during construction to document every consignment of waste removed from the site and how it is being managed. It will also record where waste has been reused and/or recycled on the site.

Table A5. 1: Waste Management Data Sheet Template

Project Component:													
Waste Category & Type	EWC Code	Date	Waste Transfer Note (Y/N)	Waste Carrier Registration Number	Name and Location of Waste Site	Permit number	Reused On Site	Reused Off Site	Recycled On Site	Treatment Required	Recycled Off Site	Recovered On/Off Site	Landfill Load Cost
INERT													
Sub TOTAL													
NON-HAZARDOUS													
Sub TOTAL													
HAZARDOUS													

Project Component:														
Waste Category & Type	EWC Code	Date	Waste Transfer Note (Y/N)	Waste Carrier Registration Number	Name and Location of Waste Site	Permit number	Reused On Site	Reused Off Site	Recycled On Site	Treatment Required	Recycled Off Site	Recovered On/Off Site	Landfill	Load Cost
Sub TOTAL														
TOTAL														

A.6 Waste Categories

A.6.1 The waste generated during construction will be assigned a European Waste Catalogue code. A list of relevant codes is provided in the table below. These codes will be provided on each waste transfer note that will accompany every movement of waste from the site.

Table A6.1: List of Waste Categories for Construction Wastes

17 Construction and demolition wastes (including excavated soil from contaminated soils)	
17 01	Concrete, bricks, tiles and ceramics
17 01 01	Concrete
17 01 02	Bricks
17 01 03	Tiles and ceramics
17 01 06*	Mixtures of, or separate fractions of concrete, bricks, tiles and ceramics containing hazardous substances
17 01 07	Mixtures of, or separate fractions of concrete, bricks, tiles and ceramics
17 02	Wood, glass and plastic
17 02 01	Wood
17 02 02	Glass
17 02 03	Plastic
17 02 04*	Glass, plastic and wood containing or contaminated with hazardous substance
17 03	Bituminous mixtures, coal tar and tarred products
17 03 01*	Bituminous mixtures containing coal tar
17 03 02	Bituminous mixtures other than those mentioned in 17 03 01
17 03 03*	Coal tar and tarred products
17 04	Metals (including their alloys)
17 04 01	Copper, bronze, brass
17 04 02	Aluminium
17 04 03	Lead
17 04 04	Zinc
17 04 05	Iron and steel
17 04 06	Tin
17 04 07	Mixed metals
17 04 09*	Metal waste contaminated with hazardous substances
17 04 10*	Cables containing oil, coal tar and other hazardous substances
17 04 11	Cables other than those mentioned in 17 04 10

17 Construction and demolition wastes (including excavated soil from contaminated soils)

17 05	Soil (including excavated soil from contaminated sites), stones and dredging spoil
17 05 03*	Soil and stones containing hazardous substances
17 05 04	Soil and stones other than those mentioned in 17 05 03
17 05 05*	Dredging spoil containing hazardous substances
17 05 06	Dredging spoil other than those mentioned in 17 05 05
17 05 07*	Track ballast containing hazardous substances
17 05 08	Track ballast other than those mentioned in 17 05 07
17 06	Insulation materials and asbestos-containing construction materials
17 06 01*	Insulation materials containing asbestos
17 06 03*	Other insulation materials consisting of or containing hazardous substances
17 06 04	Insulation materials other than those mentioned in 17 06 01 and 17 06 03
17 06 05*	Construction materials containing asbestos
17 08	Gypsum-based construction materials
17 08 01*	Gypsum-based construction materials contaminated with hazardous substances
17 08 02	Gypsum-based construction materials other than those mentioned in 17 08 01
17 09	Other construction and demolition wastes
17 09 01*	Construction and demolition wastes containing mercury
17 09 02*	Construction and demolition wastes containing PCB (for example, PCB-containing sealants, PCB-containing resin-based floorings, PCB-containing sealed glazing units, PCB-containing capacitors)
17 09 03*	Other construction and demolition wastes (including mixed-wastes) containing hazardous substances
17 09 04	Mixed construction and demolition wastes other than those mentioned in 17 09 01, 17 09 02 and 17 09 03

*denotes a hazardous waste

Annex B

Template for Resource Management Plan

Annex E

Outline Dust Management Plan



Botley West Solar Farm

Outline Dust Management Plan

08 November 2024

Approval for issue

Jonathan Alsop

8 November 2024

The report has been prepared for the exclusive use and benefit of the Applicant and solely for the purpose for which it is provided. Unless otherwise agreed in writing by RPS Group Plc, any of its subsidiaries, or a related entity (collectively 'RPS') no part of this report should be reproduced, distributed or communicated to any third party. RPS does not accept any liability if this report is used for an alternative purpose from which it is intended, nor to any third party in respect of this report. The report does not account for any changes relating to the subject matter of the report, or any legislative or regulatory changes that have occurred since the report was produced and that may affect the report.

The report has been prepared using the information provided to RPS by its client, or others on behalf of its client. To the fullest extent permitted by law, RPS shall not be liable for any loss or damage suffered by the client arising from fraud, misrepresentation, withholding of information material relevant to the report or required by RPS, or other default relating to such information, whether on the client's part or that of the other information sources, unless such fraud, misrepresentation, withholding or such other default is evident to RPS without further enquiry. It is expressly stated that no independent verification of any documents or information supplied by the client or others on behalf of the client has been made. The report shall be used for general information only.

Prepared by:

RPS
20 Western Avenue,
Milton Park, Abingdon,
Oxfordshire, OX14 4SH
United Kingdom

Prepared for:

Photovolt Development Partners GmbH,
on behalf of SolarFive Ltd.

Contents

1	OUTLINE DUST MANAGEMENT PLAN.....	3
1.1	Introduction	3
1.2	Scope of the Outline Dust Management Plan.....	3
1.3	Roles and Responsibilities	4
1.4	Process description.....	5
1.5	Sensitive receptors where impacts could occur.....	6
1.6	Routine construction phase mitigation measures	6
1.7	Decommissioning phase mitigation	9
1.8	Additional mitigation/control measures	10
1.9	Procedures to check the dust controls/mitigation are effective.....	10
1.10	Complaints action procedure	12
1.11	References	14

Tables

Table 1.1:	Daily dust inspection sheet.....	11
Table 1.2:	Form for the recording of dust-related complaint	13

1 Outline Dust Management Plan

1.1 Introduction

Background

1.1.1 This Outline Dust Management Plan is provided as an appendix to the Outline Code of Construction Practice (CoCP). It sets out the key management measures that will be implemented during the construction phase of the Botley West Solar Farm Project (referred to as the Project)

1.1.2 The Outline Dust Management Plan seeks to manage potential impacts that occur from the construction of the Project. Considering the temporary construction compounds, storage areas, accesses and mitigation areas required to support the construction of the Project.

Purpose of the Outline Dust Management Plan

1.1.3 The draft Development Consent Order (DCO) [EN010147/APP/3.1] includes a requirement for the preparation of a final CoCP. The final CoCP will be supported by a series of management plans including a Dust Management Plan (as part of the final CoCP), which must be submitted to and approved by the relevant planning authority prior to the commencement of works.

1.1.4 The purpose of this Outline Dust Management Plan is to set out the key construction dust control measures that will be required during construction of the Project.

1.1.5 This is an outline document based on the design set out in Volume 1, Chapter 6: Project Description of the Environmental Statement and includes measures that have been identified as part of the EIA process.

1.1.6 The Outline Dust Management Plan should be read in conjunction with the Outline CoCP [EN010147/APP/7.6.1] and other supporting annexes.

1.1.7 The Project lies within the administrative areas of West Oxfordshire, Cherwell and Vale of White Horse Districts, and within Oxfordshire County Council,

1.2 Scope of the Outline Dust Management Plan

1.2.1 The scope of this Outline Dust Management Plan applies to construction activities for the Project. These works comprise the following:

- Site clearance include vegetation clearance
- Demolition
- Early planting or landscaping works
- Archaeological investigations
- Environmental surveys
- Ecological mitigation
- Investigations for the purpose of assessing ground conditions

- Remedial work in respect of any contamination or other adverse ground conditions
- The diversion and laying of utilities and services
- Site security works
- The erection of any temporary means of enclosure;
- The erection of any temporary hard standing
- The erection of welfare facilities
- Creation of site accesses

1.2.2 The final Dust Management Plan will be in general accordance with the principles established in the Outline Dust Management Plan and will be agreed with the relevant authority prior to commencing the construction of the Project. For the purpose of this Plan, the term 'construction' includes all related engineering, construction and restoration activities as authorised by the DCO within the Order Limits.

1.3 Roles and Responsibilities

Overview

- 1.3.1 The key roles and associated responsibilities with regard to this Outline Dust Management Plan are set out below. The Construction (Design and Management) Regulations 2015 also identify the legal duties, responsibilities and obligations of all the major roles within the construction team.
- 1.3.2 The responsibilities of each role will be refined as necessary in the final Dust Management Plan.

Applicant

- 1.3.1.3 The Applicant will be responsible for the following:
- Ensuring that the Dust Management Plan is implemented effectively
 - Giving necessary direction to contractors (for example, setting contractual obligations)
 - Reviewing, revising and refining the Dust Management Plan (where necessary) in conjunction with the Principal Contractor.

Principal Contractor

- 1.3.3 The Principal Contractor will be appointed by the Applicant and has the overall responsibility for:
- Updating and delivering the final Dust Management Plan on behalf of the Applicant
 - Ensuring all procedures in the Dust Management Plan are followed
 - Ensuring all contractors are suitably qualified and experienced in implementing the measures within the Dust Management Plan

- Maintaining records relevant to the Dust Management Plan.

Contractors/Sub contractors

- 1.3.4** Contractors and sub-contractors will be required to understand their responsibilities and implement the measures within the Dust Management Plan (e.g. task-based lighting will be switched off after use and at the end of the working shift).

Training and competence

- 1.3.5** All construction staff will receive training as part of the site induction on the importance of managing dust from the construction works areas. Training will include the control measures within the Dust Management Plan and the reporting procedures for dust incidents. Specific training (e.g. toolbox talks) will be given for those staff involved in dust-generating construction activities and for those staff undertaking dust monitoring. All staff will be made aware of any changes to the Dust Management Plan.
- 1.3.6** Staff responsible for the operation, maintenance or repair of dust suppression systems will be trained and competent (as documented using training records).
- 1.3.7** Any sub-contractors working on site will be made aware of the Outline Dust Management Plan and will be expected to comply with it at all times.
- 1.3.8** A list of approved repair contractors will be kept in the site office and relevant site operatives will be made aware of the existence and the location of the list. Where appropriate, essential spare parts will be kept on site.

1.4 Process description

Background

- 1.4.1** The following types of activities during construction of the Project could result in fugitive dust emissions:
- Earthworks
 - Handling and disposal of spoil
 - Wind-blown particulate material from stockpiles
 - Handling of loose construction materials
 - Movement of vehicles, both on and off site (trackout).
- 1.4.2** The level and distribution of construction dust emissions will vary according to factors, such as the type of dust, duration and location of dust-generating activity, weather conditions and the effectiveness of dust suppression methods.
- 1.4.3** The main effect of any dust emissions, if not mitigated, could be annoyance due to soiling of surfaces, particularly windows, cars and laundry. However, it is normally possible, following the implementation of proper control and good practice methods (i.e. the methods described in this plan), to ensure that dust deposition does not give rise to significant adverse effects, although short-term

events may occur (e.g. due to technical failure or exceptional weather conditions).

1.5 Sensitive receptors where impacts could occur

1.5.1 The locations of sensitive receptors where impacts could occur are identified in Volume 1, Environmental Statement chapters [EN010147/APP/6.3] and includes receptors within the respective assessment areas of individual topics of the construction activities.

1.5.2 Guidance on the assessment of dust from demolition and construction (IAQM, 2024) indicates that there could potentially be annoyance dust and particulate matter (PM) with diameters of 10 micrometres or smaller (PM₁₀) effects on human health receptors located within 250 m of onsite construction activities and ecological receptors located within 50 m of onsite construction activities.

1.6 Routine construction phase mitigation measures

Overview

1.6.1 The mitigation measures outlined in this document are based on the highly recommended measures for sites with high dust risk as detailed in the Institute of Air Quality Management (IAQM) guidance on the assessment of dust from demolition and construction (IAQM 2024).

1.6.2 As summarised in Volume 1, Chapter 19: Air Quality [EN010147/APP/6.3], the predicted Dust Impact Risk without mitigation is classified as low for demolition, medium for earthworks and construction and high for tracked out dust. The general site measures described as “highly recommended” for high risks are listed below. The “highly recommended” measures for medium risk construction and high risk trackout are also listed. There are no “highly recommended” measures for medium risk earthworks.

Communications

1.6.3 The following communications measures will be adhered to throughout the construction phase:

- Develop and implement a stakeholder communications plan that includes community engagement before work commences on site
- Display the name and contact details of person(s) accountable for air quality and dust issues on the site boundary. This may be the environment manager/engineer or the site manager.
- Display the head or regional office contact information.
- Develop and implement a Dust Management Plan (DMP), which may include measures to control other emissions, approved by the Local Authority. The level of detail will depend on the risk, and should include as a minimum the highly recommended measures in this document. The desirable measures should be included as appropriate for the site. The DMP may include monitoring of dust deposition, dust flux, real-time PM continuous monitoring and/or visual inspections.

Site Management

1.6.4 The following site management measures will be adhered to throughout the construction phase:

- Record all dust and air quality complaints, identify cause(s), take appropriate measures to reduce emissions in a timely manner, and record the measures taken.
- Make the complaints log available to the local authority when asked.
- Record any exceptional incidents that cause dust and/or air emissions, either on- or off-site, and the action taken to resolve the situation in the log book.
- Hold regular liaison meetings with other high risk construction sites within 250m of the site boundary, to ensure plans are co-ordinated and dust and particulate matter emissions are minimised. It is important to understand the interactions of the off-site transport/deliveries which might be using the same strategic road network routes.

Preparing and Maintaining the Site

1.6.5 The following preparing and maintaining the site measures will be adhered to throughout the construction phase:

- Plan site layout so that machinery and dust causing activities are located away from receptors, as far as is possible.
- Erect solid screens or barriers around dusty activities or the site boundary that are at least as high as any stockpiles on site.
- Fully enclose site or specific operations where there is a high potential for dust production and the site is active for an extended period.
- Avoid site runoff of water or mud.
- Keep site fencing, barriers and any scaffolding clean using wet methods.
- Remove materials that have a potential to produce dust from site as soon as possible, unless being re-used on site. If they are being re-used on-site cover as described below.
- Cover, seed or fence stockpiles to prevent wind whipping.

Operating Vehicle/Machinery and Sustainable Travel

1.6.6 The following operating vehicle/machinery and sustainable travel measures will be adhered to throughout the construction phase:

- Ensure all vehicles switch off engines when stationary – no idling vehicles.
- Avoid the use of diesel or petrol powered generators and use mains electricity or battery powered equipment where practicable.

- Impose and signpost a maximum-speed-limit of 15 mph on surfaced and 10 mph on un-surfaced haul roads and work areas (if long haul routes are required these speeds may be increased with suitable additional control measures provided, subject to the approval of the nominated undertaker and with the agreement of the local authority, where appropriate).
- Produce a Construction Logistics Plan to manage the sustainable delivery of goods and materials.
- All machinery and plant would be procured to adhere with emissions standards prevailing at the time of procurement, where feasible and should be maintained in good repair to remain fuel efficient.
- Implement a Travel Plan that supports and encourages sustainable travel (public transport, cycling, walking, and car-sharing).

Operations (Construction Phase)

1.6.7 The following operations measures will be adhered to throughout the construction phase:

- Only use cutting, grinding or sawing equipment fitted or in conjunction with suitable dust suppression techniques such as water sprays or local extraction, e.g. suitable local exhaust ventilation systems.
- Ensure an adequate water supply on the site for effective dust/particulate matter suppression/mitigation, using non-potable water where possible and appropriate.
- Use enclosed chutes and conveyors and covered skips.
- Minimise drop heights from conveyors, loading shovels, hoppers and other loading or handling equipment and use fine water sprays on such equipment wherever appropriate.
- Ensure equipment is readily available on site to clean any dry spillages, and clean up spillages as soon as reasonably practicable after the event using wet cleaning methods.

Waste management

1.6.8 The following waste management measures will be adhered to throughout the construction phase:

- No bonfires or burning of waste material.

High Risk Measures Specific to Earthworks

1.6.9 Measures that will be implemented that are specific to earthworks are the following:

- Use Hessian, mulches or tackifiers where it is not possible to re-vegetate or cover with topsoil, as soon as practicable.

- Re-vegetate earthworks and exposed areas/soil stockpiles to stabilise surfaces as soon as practicable.
- Only remove the cover in small areas during work and not all at once.

Medium Risk Measures Specific to Construction

1.6.10 Measures that will be implemented that are specific to construction are the following:

- Ensure sand and other aggregates are stored in bunded areas and are not allowed to dry out, unless this is required for a particular process, in which case ensure that appropriate additional control measures are in place.

High Risk Measures Specific to Trackout

1.6.11 Measures that will be implemented that are specific to trackout are the following:

- Use water-assisted dust sweeper(s) on the access and local roads, to remove, as necessary, any material tracked out of the site. This may require the sweeper being continuously in use
- Avoid dry sweeping of large areas
- Ensure vehicles entering and leaving sites are covered to prevent escape of materials during transport
- Inspect on-site haul routes for integrity and instigate necessary repairs to the surface as soon as reasonably practicable
- Record all inspections of haul routes and any subsequent action in a site log book
- Install hard surfaced haul routes, which are regularly damped down with fixed or mobile sprinkler systems, or mobile water bowsers and regularly cleaned.
- Implement a wheel washing system (with rumble grids to dislodge accumulated dust and mud prior to leaving the site where reasonably practicable)
- Ensure there is an adequate area of hard surfaced road between the wheel wash facility and the site exit, wherever site size and layout permits
- Access gates to be located at least 10 m from residential properties/schools and healthcare facilities where possible.

1.7 Decommissioning phase mitigation

1.7.1 Prior to the commencement of the decommissioning phase, a decommissioning plan will be submitted to West Oxfordshire, Cherwell and Vale of White Horse Districts, and Oxfordshire County Council and applied where necessary. An Outline Decommissioning Plan has been prepared and submitted alongside the DCO submission [EN010147/APP/7.6.4].

1.7.2 The most probable measures that will be undertaken to mitigate air quality and dust issues are the same as during the construction phase.

1.8 Additional mitigation/control measures

1.8.1 Trigger levels have been defined to reduce nuisance dust effects at the nearest receptors during high-risk conditions.

1.8.2 The trigger levels established for the site include any of the following occurring, singly or in combination:

- Winds that are or are forecast to be, above a moderate breeze (Beaufort scale 4 – described as conditions under which dust and loose paper are raised, small branches begin to move) on days when there has been no rainfall for the last three days or more
- Routine checks/inspections/surveys on site have identified evidence of dust off-site
- A dust complaint is received
- A failure in equipment or control is identified or an abnormal/unintentional situation occurs, e.g. a spillage.

1.8.3 The additional controls to be employed if a trigger level is exceeded are set out below:

- Increase frequency of use of the road sweeper, both on-site and on local roads
- Temporary cessation of the activities responsible for causing the dust impact until the trigger level is no longer exceeded
- Use of additional dust suppression measures such as dampening of specific surfaces
- Relocation of activities so that the distance between the source of emissions and the receptors is increased.

1.8.4 The additional control measures listed in paragraph 1.8.3 will be implemented (either singly or in combination) as necessary to effectively control dust emissions, as evidenced by the visual and monitoring checks described in the section 1.9.

1.8.5 The site manager will be responsible for implementing these risk management measures in accordance with procedures.

1.9 Procedures to check the dust controls/mitigation are effective

Monitoring

1.9.1 The results of the inspections will be recorded in a site log. The prevailing weather conditions and the activities undertaken at the time of the inspection will also be recorded in the site log.

1.9.2 If any of the trigger levels in section 1.8 are exceeded and additional measures are employed, the frequency of the visual site boundary inspection will increase to twice a day until such time as no dust is visible leaving the construction works area boundary. If after two days, the results of such monitoring indicate that the additional control measures are not effective, the site manager will instruct all site operatives that the operations will cease until the issue can be resolved.

1.9.3 An example daily dust inspection sheet has been provided in Table 1.1.

Table 1.1: Daily dust inspection sheet

Dust Inspections sheet			Date		
Time of test					
Location of test e.g. street name etc					
Weather conditions (dry, rain, fog, snow etc):					
Temperature (very warm, warm, mild, cold or degrees if known)					
Wind strength (none, light, steady, strong, gusting) Use Beaufort scale if known					
Wind direction (e.g. from NE)					
Duration (of test)					
Constant or intermittent in this period or persistence					
Receptor sensitivity (see below)					
Is the source evident?					
Any other comments or observations					

Monitoring dust complaints

- 1.9.4 Complaints received during the construction process will be recorded in accordance with the principles in section 1.10. Complaints are an important indicator of community dissatisfaction and provide a useful form of monitoring. However, it is important to bear in mind that complaints are only a symptom of annoyance or nuisance; there are various reasons why complaint records are not an exact indicator of dust annoyance or nuisance itself. Nevertheless, the collection, maintenance and analysis of complaints records is an important method of indicating the effectiveness or otherwise of measures implemented to reduce nuisance due to dust.
- 1.9.5 The site manager will implement a system of complaints monitoring and analysis. Complaints will be collected, registered and validated as described in section 1.10 of the Dust Management Plan. The record of complaints received at the end of each calendar quarter will be reviewed to identify:
- Trends, in terms of the subject, cause or origin of complaints
 - Aspects experienced at one location that could apply to other locations.
- 1.9.6 Any action deemed necessary because of the analysis shall be identified and discussed in order to programme a course of corrective actions.

1.10 Complaints action procedure

Receipt of a complaint

- 1.10.1 If any complaint is made by a member of the public about any matter associated with the construction works area, the site manager/responsible person will give notice in writing to West Oxfordshire, Cherwell and Vale of White Horse Districts, and Oxfordshire County Council no later than the next working day after the complaint is received. This written notification will normally be in the form of an email. The notification will include a description of the complaint, the name and address of the person making the complaint (if available) and the action proposed as a result. Depending on the nature of the complaint, it will not always be possible to resolve the matter within this short timescale. In such cases an indication will be given that further investigations are necessary.
- 1.10.2 Once a complaint has been received, the complaint details will be registered.

Complaint registration

- 1.10.3 A record of all complaints received will be maintained. In the event that a complaint is received alleging potential dust nuisance from the construction site:
- The complaint will be fed into a registration system
 - Complaints data should be recorded in a systematic way, enabling comparison with standard dust descriptors, with wind direction and with site work activities.

1.10.4 A standardised form will be used for recording this information and entering it into the registration system, shown in Table 1.2.

Table 1.2: Form for the recording of dust-related complaint

Dust Complaint Report Form		Sheet No	
Date:		Time:	
Name and address of complaint:			
Tel no. of complaint:			
Time and date of complaint:			
Date, time and duration of offending dust:			
Location of dust, if not at above address:			
Weather conditions (i.e., dry, rain, fog, snow):			
Wind strength (light, steady, strong, gusting) or use Beaufort scale:			
Wind direction:			
Complainant's description of dust (e.g. colour, particle size):			
Has complaint any other comments about the dust?			
Are there any other complaints relating to the installation or to that location? (either previously or relating to the same exposure)			
Any other relevant information:			
On-site activities at time the dust occurred:			
Operating condition at time nuisance dust occurred/identified.			
Actions taken:			
Form completed by			Signed

Responding to a complaint

- 1.10.5 For answerphone messages and complaints submitted by email or by letter, an acknowledgement and initial response will be given by telephone or by email within 72 hours, provided that telephone or email contact details have been given by the complaint. The site manager will respond as rapidly as possible to the complaint to maximize the opportunity for identifying the source of the nuisance dust. Where possible, the site manager or an appropriate representative of the site manager, will inspect the nuisance dust location referred to in the complaint.
- 1.10.6 Where complaints cannot be resolved on initial contact and further investigations are required, a written response will be made within 10 working days of submission of the complaint. The complaint will be told if this is the case and how long it will take to give a response.
- 1.10.7 The primary reasons for further investigation of complaints are to assess potential nuisance and identify the likely cause and source of the dust so that nuisance can be reduced or stopped. In the case of further investigations, the site manager will communicate to the complaint the course of actions likely to be taken. In summary, the response will include:
- The reason for the nuisance dust event
 - The likely duration of the nuisance dust event
 - What plan is in place to end the nuisance dust event
 - What preventative plan will be implemented to prevent a re-occurrence
 - What grievance procedure the aggrieved party can take.

Investigation of dust complaints

- 1.10.8 The site manager will investigate the complaint and will provide a response. The response will be by letter or email or, if preferred, a telephone call.
- 1.10.9 The investigation will aim to capture evidence to establish whether the nuisance dust identified is attributable to the construction activities. If the source of the nuisance dust is deemed to be the construction activities, the information recorded will be used to identify if there has been a failure in the existing mitigation/control measures or the need for a new mitigation/control measure. If a new mitigation/control measure is required, the site manager will update the Dust Management Plan.

1.11 References

IAQM (2024) Guidance on the assessment of dust from demolition and construction. Available at: <https://iaqm.co.uk/guidance/>. Accessed: September 2024.

Annex F

Bentonite Breakout Plan

Outline bentonite breakout plan

1.1 Introduction

This document forms the Outline Bentonite Breakout Plan prepared for the Botley West Solar Farm (referred to hereafter as 'the Project').

1.2 Implementation

This Outline Bentonite Breakout Plan forms an appendix to the Outline Code of Construction Practice (OCoCP).

A detailed Bentonite Breakout Plans will be prepared as a part of the detailed Code of Construction Practice(s) on behalf of the Applicant, prior to commencement of the relevant stage of works and will follow the principles established in this Outline Bentonite Breakout Plan (OBBP). The detailed Bentonite Breakout Plans will require approval by the relevant planning authority following consultation with relevant stakeholders. The Applicant and all relevant appointed contractors will be responsible for the implementation of the detailed Bentonite Breakout Plans.

The Applicant has committed to implementation of detailed Bentonite Breakout Plan via the following commitment, and it is secured by inclusion of a Requirement in the draft Development Consent Order (DCO) which states:

No stage of the Project works may commence until for that stage a code of construction practice has been submitted to and approved by the relevant planning authority following consultation as appropriate with Oxfordshire County Council, Natural England, the Environment Agency.

The Project may adopt a phased approach to the approval of DCO requirements. This will enable requirements to be approved in full or in part prior to the commencement of the relevant stage of works depending on whether the Project is delivered in one stage or multiple stages.

1.3 Sensitive features

Features have been identified along the cable corridor where use of open cut trenching techniques has been discounted or are less favourable due to the sensitivity of the features encountered. The obstacles identified along the route and proposed crossing methodologies being considered are presented within the Crossing Schedule.

One of the trenchless crossings proposed along the cable corridor is the crossing of a Main River designated by the Environment Agency (EA). The designation of 'Main River' is made by the EA generally to larger arterial water courses. For crossings beneath a 'Main River' consultation and approval from the EA is required. The Project Description sets out where the Grid Connection Cable Corridor passes beneath features such as rivers, roads, railways or significant landscape features, trenchless installation techniques such as Horizontal Directional Drilling (HDD), direct pipe or micro tunnel will be used to avoid open cut trenching and associated surface disturbance.

1.4 Context

Horizontal Directional Drilling (HDD) carries a risk of bentonite breakout due to the high downhole pressures and volumes of drilling fluid involved in the process.

Within an HDD, drilling fluid is required to:

- suspend and carry the drill cuttings from drill bit to the surface;
- stabilize the HDD bore during drilling to prevent collapse and minimize risk of loss of drilling fluid or influx of groundwater to the bore;
- cool the cutting head and reamers (cutting tools);
- make the drill string more buoyant;
- power the mud motor; and
- lubricate the drilling head, drill string during drilling phases and High-Density Polyethylene (HDPE) strings during pullback.

The risk of breakout of drilling fluid from the HDD bore into the surrounding ground may occur where downhole pressures exceed the confining ground pressure and have the potential to migrate to the surface and is depending on:

- Geological conditions: Risk increases in coarse-grained sands/gravels, fractured or fissured rock, organic/soft soils, and karst formations; risk decreases in homogeneous, low-permeability clays.
- Cover depth: Shallow cover significantly raises the likelihood of breakout and greater depth provides more pressure containment.
- Bore design and alignment: Long sections, tight radii and steep entry/exit angles could lead to higher drilling fluid pressures.
- Annular pressure / pump rate: High flow rates, thick mud, or too large reamer steps could push pressures above the fracture threshold.
- Reaming strategy: Large diameter jumps, inadequate hole cleaning, and high cuttings content can create sudden pressure spikes.
- Existing ground conditions: Old utilities, loose or poorly compacted backfill, abandoned boreholes, and natural fractures offer preferential pathways for fluid escape.

1.5 Bentonite-based drilling fluid composition

The drilling fluid used during HDD generally comprises a mixture of water and bentonite (a mined naturally occurring clay). The bentonite is delivered to site as a dried and finely ground powder and is mixed with water to form a slurry. Bentonite typically comprises 1%-5% by volume of the drill fluid depending on the ground conditions present. In addition to the bentonite, certain proprietary additives (such as polyanionic cellulose or partially hydrolyzed polyacrylamide polymers) may be added to the drilling fluid during drilling to control its rheological and / or thixotropic properties.

Bentonite is classified as 'not hazardous' under Classification Regulation (EC) No 1272/2008 and is not classified within the Classification Directive 67/548/ECC nor 1999/45/EC as the product is not hazardous.

1.6 Potential drilling fluid breakout

Drilling fluid breakout to the surface most commonly occurs at the HDD entry and exit points where the bore is at its shallowest. The likelihood of drilling fluid breakout occurring decreases with depth.

Drilling fluid is most likely to breakout of the HDD bore where highly fissured ground or highly permeable ground (coarse granular materials, peat, voids) are encountered.

Breakouts may also occur where man-made features are present (e.g. old site investigation boreholes).

In the event of drill fluid breakout from the bore it is only likely to reach ground level where there is a continuous path to the surface or where the drill fluid pressure exceeds the overburden pressure. The overburden pressure is the pressure exerted on a specific depth underground by the weight of the layers of material above it.

1.7 Breakout risk reduction

To keep the likelihood of bentonite breakout as low as possible, both site conditions and drilling practices will be addressed. The following measures are commonly used to reduce risk:

- Geotechnical Surveys before drilling: test soil permeability & shear strength, estimate fracture pressure
- Optimized Bore Path & Depth: gentle curves, avoid shallow cover in sensitive areas
- Gradual Reaming with small diameter increments
- Adjust Fluid Properties to match ground type, avoid overly viscous mixes
- Continuous Pressure & Return Monitoring

1.8 Breakout mitigations

Equipment allowing monitoring of downhole drill fluid pressure will be used to allow real time comparison with limit values from hydrofracture analysis. If the allowable pressure is exceeded the trenchless crossing works would be stopped and blockage cleared (by repeated pull back and advancement of drilling head, possibly with alternative drill head) before continuing to drill.

Ground investigation would be undertaken at the entry and exit pit and along the trench to establish ground conditions and gather relevant geotechnical information to allow trenchless crossing design and hydrofracture analysis to be undertaken at the detailed design stage.

To mitigate the risk of surface breakout close to the entry of the hole, casing made of strong and durable material and able to withstand the stress imposed during the drilling, could be installed to provide physical containment of the drill fluid within the casing and/or pressure of the drilling fluid could be reduced when close to the entry and exit pits.

Additional visual monitoring along the length of the bore will be undertaken (where land access is available) to check for signs of breakout to the surface.

When crossing beneath 'Main Rivers' a minimum trenchless crossing depth of 5m below hard bed level will be achieved through appropriate design of the drill. To further mitigate the impacts of potential drill fluid breakout, the HDD crossing entry and exit points will be sufficiently set back from watercourses to ensure sufficient depth achieved in immediate

proximity to the watercourse crossing, a minimum 10m from 'Main Rivers' will be committed to by the Applicant. The final trenchless crossing depth for each proposed drill will be defined at detailed design based on results of ground investigations, proposed trenchless technique to be utilized and detailed design.

1.9 Breakout response

If drilling fluid breakout occurs this would be able to be identified quickly at the trenchless entry compound due to falling fluid levels within mud tanks, allowing works to be stopped and action taken to seal the area of loss.

For a breakout from a HDD bore, bentonite would be reintroduced periodically to the bore under pressure to plug the breakout. If this proves unsuccessful then loss circulation materials may be introduced to the drilling fluid to plug the point of breakout.

An outline of response sequence if bentonite breakout is identified at the surface is as follows:

- On identification of breakout to the surface the drilling would be immediately stopped, decreasing fluid pressure preventing further fluids migrating to the surface;
- The bentonite breakout would be contained using sandbags, earth bunds, straw bales, silt fencing etc;
- The bentonite breakout would be covered with absorbent granules to increase viscosity, turning the drill fluid into thick clay which can be removed from the surface. Alternatively for larger volumes, a vacuum tanker or suction pump and hose may also be required; and
- All drilling fluid at surface level would be transported to the drilling compound and assessed if suitable for reuse. If identified as unsuitable for reuse, then the material would be transported to an approved waste facility.

A review of the design parameters used for the trenchless crossing would be undertaken to establish if update in design or construction method statement is needed such as trenchless crossing profile, drill fluid mixture or drilling pressures.

1.10 Breakout notification

The notification process will be agreed in advance in the finalized bentonite breakout plan. Notification of a bentonite breakout will be provided to the relevant parties, if identified to have occurred, along with details of how the bentonite drill fluid has been or will be removed.

1.11 References

The Council of the European Economic Community (1967) Council Directive 67/548/EEC of 27 June 1967 on the approximation of laws, regulations and administrative provisions relating to the classification, packaging and labelling of dangerous substances, L196, 16 August 1967, pp. 1–98.

The European Parliament and the Council of the European Union (1999) Directive 1999/45/EC of the European Parliament and of the Council concerning the approximation of the laws, regulations and administrative provisions of the Member States relating to the classification, packaging and labelling of dangerous preparations, L200, 30 July 1999, pp. 1–68.



The European Parliament and the Council of the European Union (2008) Regulation (EC) No 1272/2008 of the European Parliament and of the Council of 16 December 2008 on classification, labelling and packaging of substances and mixtures, amending and repealing Directives 67/548/EEC and 1999/45/EC, and amending Regulation (EC) No 1907/2006, L353, 31.12.2008, pp. 1–1355.

Annex G

Ecology Pre-commencement Survey Methodology

Introduction

The following sets out the methodologies to be adopted for the pre-commencement ecology surveys to be undertaken to ensure that the baseline for ecology mitigation is up to date. Each entry specifies survey standard, seasonal timing, survey effort, method statement expectation and licence expectation.

At this stage, such surveys would comprise those for:

- dormice;
- great crested newt;
- badger;
- reptiles;
- arable weeds; and
- otter and water vole

This list is not exhaustive; if surveys for other species groups were considered necessary then appropriate methods/mitigation would be agreed with stakeholders including the relevant planning authorities and Natural England.

Dormice

Survey standard: nest tube and nest box survey of all impacted hedgerows and any that connect with such features. Surveys in accordance with Bright, Morris & Mitchell-Jones, The Dormouse Conservation Handbook (Natural England, 2025).

Seasonal timing: April to November

Survey effort: minimum 50 tubes per survey unit with monthly checks.

Licence expectation: an EPS mitigation licence under the Conservation of Habitats and Species Regulations 2017 (as amended) is anticipated. Method statement to accompany the licence application covering precautionary working and vegetation clearance methodology.

Great crested newt

Survey standard: Habitat Suitability Index assessment and eDNA survey (following Briggs *et al.* 2014) followed, where required, by and population size-class surveys (bottle trapping, torch, egg search, netting) in accordance with Natural England guidance (English Nature 2001).

Seasonal timing: mid-March to mid-June (eDNA window 15 April – 30 June).

Survey effort: all waterbodies within 500m of works.

Licence expectation: a Natural England EPS mitigation licence or District Level Licence, per oLEMP §8.3.1. Method statement to accompany the licence application, covering precautionary working, exclusion fencing, capture and translocation, and receptor site provision.

Badger

Survey standard: sett survey and, where considered necessary, bait-marking in accordance with Harris, Cresswell & Jefferies, Surveying Badgers (Mammal Society, 1989) and current Natural England guidance.

Seasonal timing: surveys undertaken year-round; optimal detectability October to April when vegetation is low.

Survey effort: full walkover within the construction footprint plus 30m buffer (consistent with oLEMP §8.4.1).

Licence expectation: a Natural England licence under the Protection of Badgers Act 1992 where sett disturbance, closure or destruction is required, per oLEMP §8.4.2. Method statement to cover timing restrictions (no closures during breeding season) and artificial sett provision, if required.

Reptiles

Survey standard: presence/absence using artificial refugia and direct observation in accordance with Froglife Advice Sheet 10 (1999) and Herpetofauna Groups of Britain and Ireland methodology.

Seasonal timing: April to September, avoiding peak summer temperatures; minimum seven visits in optimal conditions (temperature, time of day, weather).

Survey effort: refugia deployed at a density consistent with the habitat extent.

Licence expectation: no licence required; common reptiles are protected against killing and injury only under Schedule 5 Wildlife and Countryside Act 1981 (as amended). Method statement to be produced to cover phased vegetation cut, staged habitat manipulation, translocation to receptor habitat (if required), and supervision by an ecologist consistent with oLEMP §8.8.

Arable weeds

Survey standard: arable plant assemblage survey in accordance with Plantlife and BSBI guidance (Plantlife, Important Arable Plant Areas methodology).

Seasonal timing: one-two visits, ideally early summer (June) and late summer (August/September), to capture both early- and late-flowering species.

Survey effort: transects across representative field margins within the construction footprint.

Licence expectation: no licence required. Method statement to cover translocation of seedbank or topsoil where species of conservation significance are identified.

Otter and water vole

Surveys for otter and water vole were not undertaken at Environmental Statement stage. The Applicant will develop the pre-commencement survey methodology, method statements and any necessary licence applications in consultation with Natural England, the OHA and Environment Agency as follows:

Survey standard: otter – spraint, holt and couch survey along watercourses within and adjacent to the construction footprint, in accordance with Chanin (2003) Monitoring the

Otter (English Nature); water vole – field sign survey (burrows, latrines, runs, feeding stations) in accordance with Dean, Strachan, Gow & Andrews (2016) *The Water Vole Mitigation Handbook*.

Seasonal timing: otter – two visits, spring and autumn; water vole – two visits between April and September, at least two months apart, with at least one between mid-April and June.

Reporting: Survey reports sharing with Natural England, the OHA and Environment Agency. Where presence is confirmed, a method statement will be prepared in consultation with Natural England, as required.

Method statements: covering construction stand-offs from watercourses (minimum 10m buffer per oLEMP §8.2.6), timing restrictions, ecological supervision, and any temporary displacement or translocation.

Licence applications: where works would otherwise constitute an offence, applications will be made to Natural England's Wildlife Licensing Team under the Conservation of Habitats and Species Regulations 2017 (as amended) (otter) or the Wildlife and Countryside Act 1981 (as amended) (water vole).

References

Briggs, L., Foster, J., Wilkinson, J.W., Arnett, A., Williams, C. & Malcolm, C. (2014). eDNA testing for Great Crested Newts: Interim technical guidance for surveyors.

Froglife/Freshwater Habitats Trust, Peterborough.

Bright, P., Morris, P. & Mitchell-Jones, T. (2025). *The Dormouse Conservation Handbook*. Natural England, Peterborough.

English Nature (2001). *Great Crested Newt Mitigation Guidelines*. English Nature, Peterborough.

Harris, S., Cresswell, P. & Jefferies, D. (1989). *Surveying Badgers*. The Mammal Society, London.

Froglife (1999). *Froglife Advice Sheet 10: Reptile Survey: An Introduction to Planning, Conducting and Interpreting Surveys for Reptile Conservation*. Froglife, Peterborough.

Wilkinson, J.W. & Arnett, A.P.R. (eds) (2011). *Herpetofauna Workers' Manual*. Amphibian and Reptile Conservation, Bournemouth.

Chanin, P. (2003). *Monitoring the Otter*. Conserving Natura 2000 Rivers Monitoring Series No. 10. English Nature, Peterborough.

Dean, M., Strachan, R., Gow, D. & Andrews, R. (2016). *The Water Vole Mitigation Handbook*. The Mammal Society/Natural England, London.